



Maintenance Manual for Embroidery Machine

HCD2-1501-40

Version 1.0



HAPPY Industrial Corporation

For safe adjustment and repair

In order to conduct adjustment and repair safely and surely,
please be sure to abide by what is mentioned in this manual to prevent trouble.



1. When you conduct adjustment and repair of this embroidery machine or handle electric related parts, you are required to take technical lesson in advance.
2. When you conduct adjustment and repair using this manual, please be sure to use together with instruction with it in hand.

Please conduct in accordance with work process in this manual.

In case there are no specific instructions or explanations in work process.
please be sure to unplug cord from receptacle.

When you exchange parts, please be sure to use genuine parts designated by us.

Please never remodel the embroidery machine.

When you handle circuit boards:

In order to prevent troubles from static electricity, please remove earth from human body.

Please don't touch metal part of circuit board with bare hand as it will short-circuit
and threaten to break circuit boards.

When you removed circuits boards from the machine or you store or transport them,
please wrap them in static electricity preventive bag and avoid to give shock.

Index

	page
For safe adjustment and repair	2
Index	3
Special tool, Measuring equipment, Other	8
1 Outline of mechanism	
1-1 Outline of mechanical mechanism.	11
1-2 Placement of key electronic parts	13
2 Outer covers	
2-1 Removal of thread guide ass'y, thread guide pillar and thread stand.	11
2-2 Removal of outer covers.	13
3 Mechanical mechanism.	
3-1 Basic maintenance.	
3-1-1 Maintenance of thread path.	17
3-1-2 Fixing of needle.	19
3-1-3 Selection of thread.	20
3-1-4 Relation between needle and upper thread.	21
3-2 Fixed head.	
3-2-1 Exchange of crank ass'y.	22
3-2-2 Exchange of rod.	30
3-2-3 Exchange of pressure foot arm ass'y	32
3-2-4 Exchange of pressure foot cam.	33
3-2-5 Adjustment of the lowest needle point.	35
3-2-6 Exchange of needle bar driver.	36
3-2-7 Adjustment of fixing of jump device	37
3-2-8 Exchange of roller shaft ass'y.	38
3-2-9 Adjustment of take-up lever timing.	39
3-2-10 Check of height of pressure foot.	40
3-2-11 Exchange / Adjustment of pressure foot	41
3-2-12 Fixing of thread catcher.	43

Index

	page
3-3 Moving head.	
3-3-1 Assemble and remove moving head.	45
3-3-2 Fixing of upper rail.	48
3-3-3 Adjustment of backlash (back and forth) of moving head.	49
3-3-4 Adjustment of needle position (back and forth).	50
3-3-5 Check of needle position.	51
3-3-6 Adjustment of needle height.	52
3-3-7 Exchange of needle bar, needle bar spring, cushion and pressure foot block.	54
3-3-8 Fixing of needle bar boss check plate	56
3-3-9 Exchange of take-up lever.	57
3-3-10 Adjustment of thread holder.	59
3-3-11 Exchange of majic-tape on thread holder.	60
3-4 Needle bar change unit	
3-4-1 Fixing of needle bar change unit	61
3-4-2 How to take out needle bar change stop position sensor and needle position sensor (potentiometer)	62
3-4-3 Setting to detect needle position	63
3-5 Rotary hook	
3-5-1 Exchange and adjustment of rotary hook timing	65
3-5-2 Adjustment of retainer on rotary hook	67
3-6 Thread cut unit	
3-6-1 Adjust for thread trim sensor and stopper	68
3-6-2 Exchange of moving knife	70
3-6-3 Exchange of fixed knife	71
3-6-4 Adjustment of moving knife and fixed knife	72
3-6-5 Adjustment of position of moving knife	73
3-6-6 Adjustment of bobbin thread holder	74
3-6-7 Exchange of keeper solenoid	75
3-6-8 Adjustment of position of keeper	77

Index

	page
3-7 Carriage unit	
3-7-1 Adjustment of X carriage belt tension	78
3-7-2 Exchange of X carriage belt	80
3-7-3 Adjustment of Y carriage belt tension	82
3-7-4 Exchange of Y carriage belt	85
3-7-5 X carriage limit sensor replacement and adjustment	88
3-7-6 Y carriage limit sensor replacement and adjustment	89
3-8 Transmission unit	
3-8-1 Adjustment of timing belt tension	90
3-8-2 Exchange of timing belt	91
3-8-3 Exchange of main shaft timing board	93
3-8-4 Adjustment of detecting slit and timing slit	94
4 Exchange and Setting of electric related component	
4-1 Exchange of fuse.	90
4-2 Exchange of CONT-D2 board	91
4-3 Exchange of switching power supply and adjustment of power voltage output and of power failure detection	
4-3-1 Exchange of switching power supply	98
4-3-2 Adjustment voltage output of 24V switching power supply.	100
4-3-3 Adjustment voltage output of 36V switching power supply.	101
4-4 Exchange of cooling fan (2 places)	102

Index

	Page
5 Parts Replacement in control box and setting	
5-1-1 Remove control box	103
5-1-2 Remove LCD-CE board	104
5-1-3 Setting for LCD-CE board	106
6 Exchange and setting of Inverter	
6-1 Exchange Inverter	
6-1-1 Remove Inverter	107
6-1-2 Inverter Installation	109
6-2 Setting of inverter	
6-2-1 How to set inverter	112
6-2-2 Initialization of parameter	114
7 Program update procedure	115
7-1 Preparation for program update	116
7-2 Machine program update	117
7-3 Machine program update	119
7-3a Machine program update	120
7-4 Setting of revolution	121
Re-Initialization of machine system	
Initializing of machine speed	
8 Maintenance mode	122
8-1 How to enter Maintenance mode	122
8-2 Machine Test —Machine movement	123
8-3 Memory All Clear—Initialization of design memory	125
8-4 Record—Operation data display	126
8-4-1 Total number of stitch	126
8-4-2 Record of Error occurrence	127
8-4-3 Number of occurrence in each error display	128
8-4-4 Thread break history	129
8-5 Setup—Machine setting	130
8-6 Position—Registration of coordinates for positioning sensor.	132

Index

	Page
9 Installation and setting of option unit	
9-1 Installation, setting and adjustment of needle sensor	134
9-1-1 Installment of safety sensor	134
9-1-2 Setting procedure	137
9-1-3 Adjustment of optical axis	138
9-2 Installment of Bobbin winder	139
10 Electric system diagram	
10-1 Electrical connection diagram (for LCD-CE board)	143
10-2 Electrical connection diagram (for LCD-CE-U, LCD-CE-MX board)	146
10-3 Connection of inverter	150
10-4 Explanation of function of circuit board	151
11 Others	
11-1 How to respond for some question (As example step)	157
11-2 Trouble shooting	
11-2-1 Electricity doesn't turn on	158
11-2-2 Thread break	159
11-2-3 Erraneous thread cut	164
11-2-4 Off-registration of pattern	166
11-2-5 Upper thread comes off from needle hole	169
11-2-6 Upper thread remains	171
11-2-7 Malfunction of thread break detection	172
11-2-8 Suspension of upper shaft	174
11-2-9 Malfunction of needle bar change	175
11-2-10 Defect on thread catcher	176
11-2-11 Others (Mechanical)	177
11-2-12 Others (Electronically)	178
11-3 Error	
11-3-1 Error and measure	179
11-4 Reference date	
11-4-1 Tables for timing / adjustment value	184

Special tool, Measuring equipment, Other

HSA90020

2.0mm thickness gauge (Page 76)

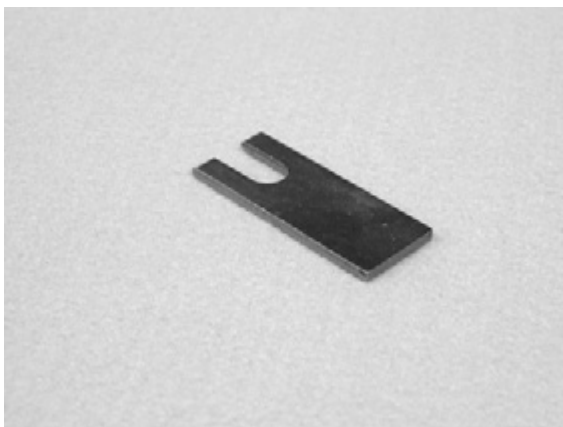

HSA90080

Retainer positioning gauge [0.8mm] (Page 67)



HSA90030

Keeper positioning gauge (Page 77)



HSA90090

Positioning pin (Page 39)

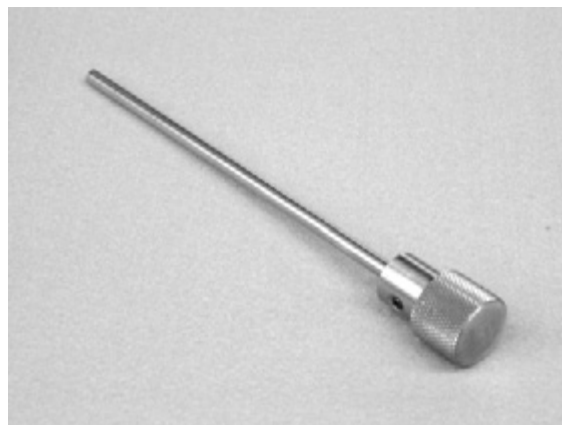

HSA90051

Bering positioning gauge [4.85mm] (Page 38)

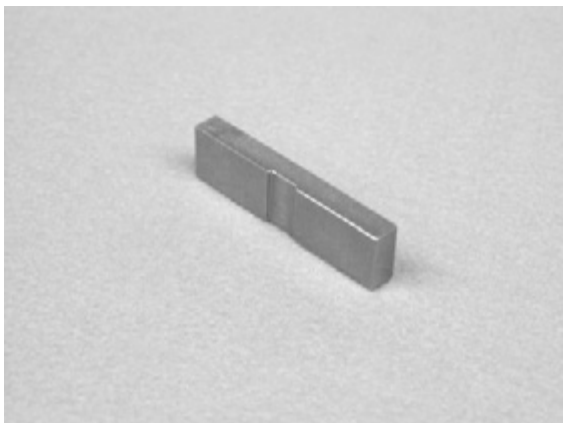

HSA90131

1.2mm thickness gauge (Page 40, 42)



HSA90210

0.2mm thickness gauge (Page 58)



HSA90240

Dial-gauge set (Page 35)

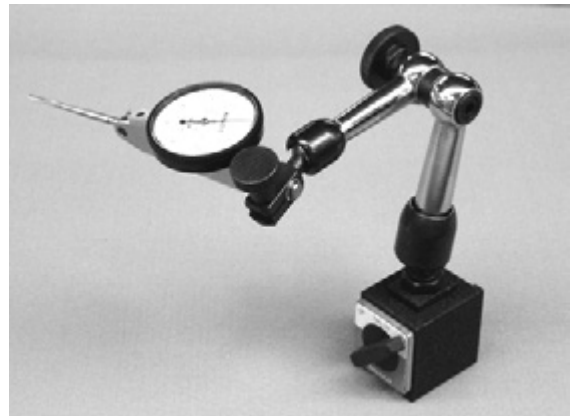

HSA90220

6mm positioning pin (Page 87)

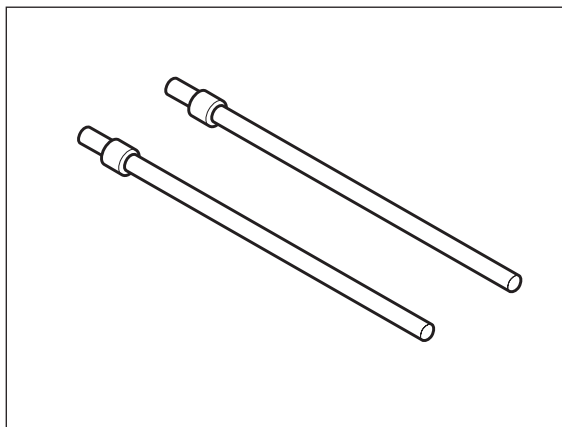

HSA90270

Vernier calliper gauge [200mm] (Page 34)

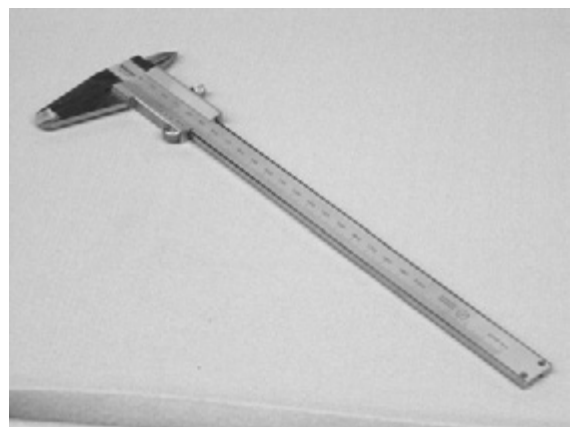

HSA90230

Tensile gauge (Page 74)



HSA90300

Tension gauge 2000cN (Page 78, 83)



HSA90311

Shell alvania EP Grease2 100g

(Page 31, 33, 36)

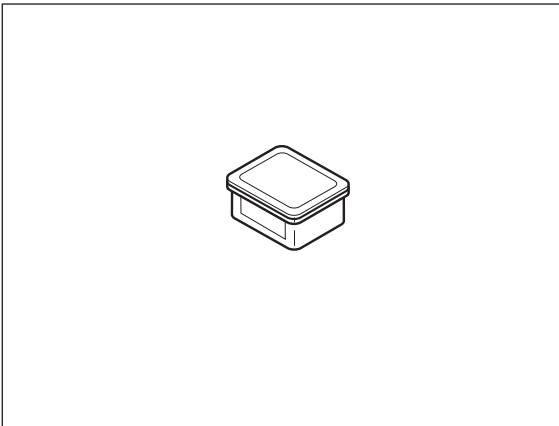

M0404342

Needle height gauge (Page 52)

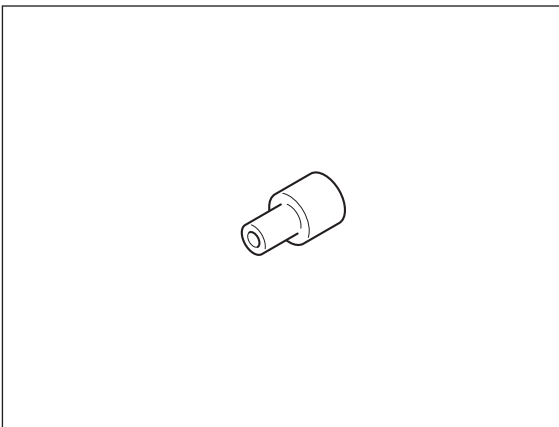

1-1 Outline of mechanical mechanism

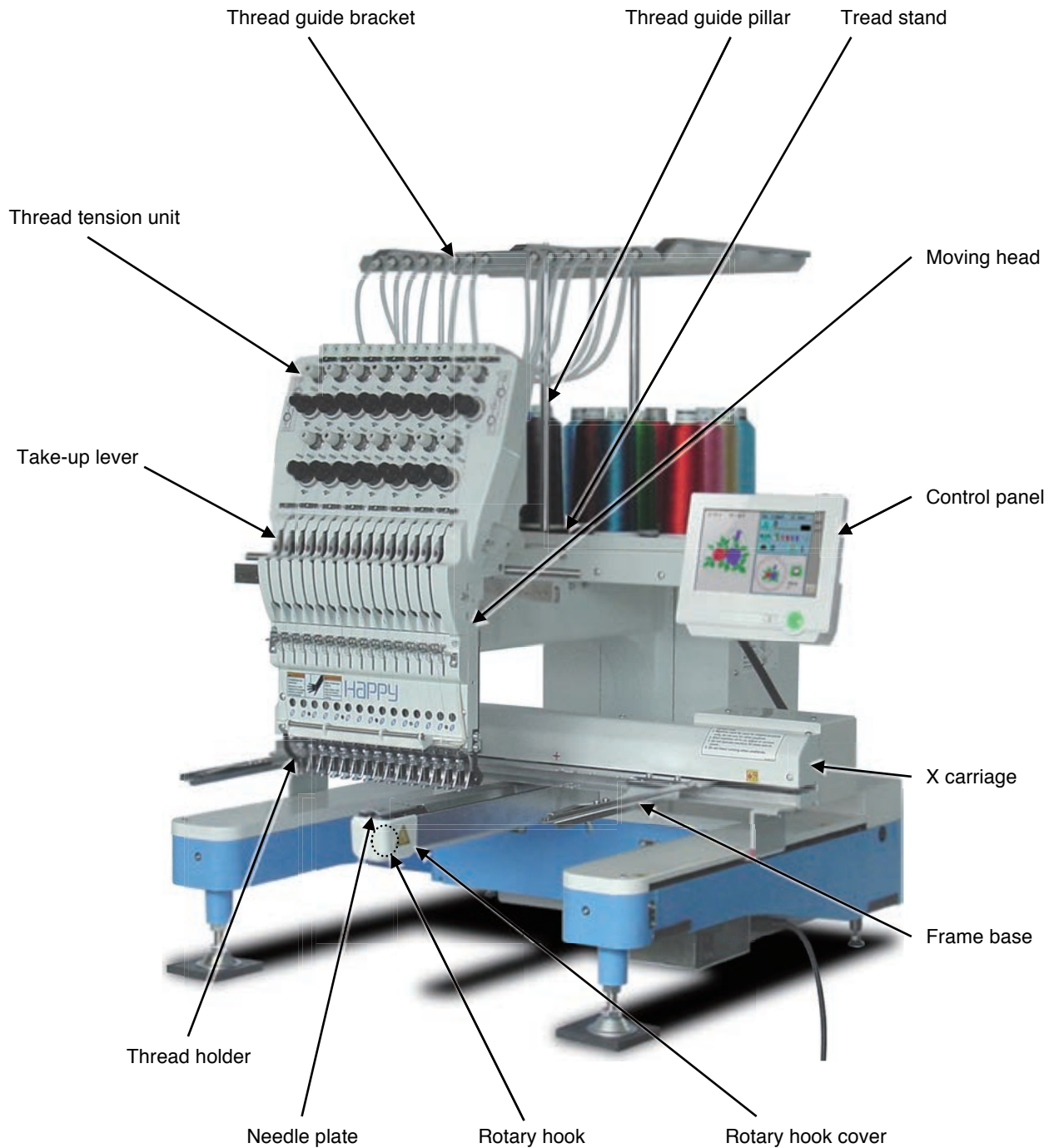

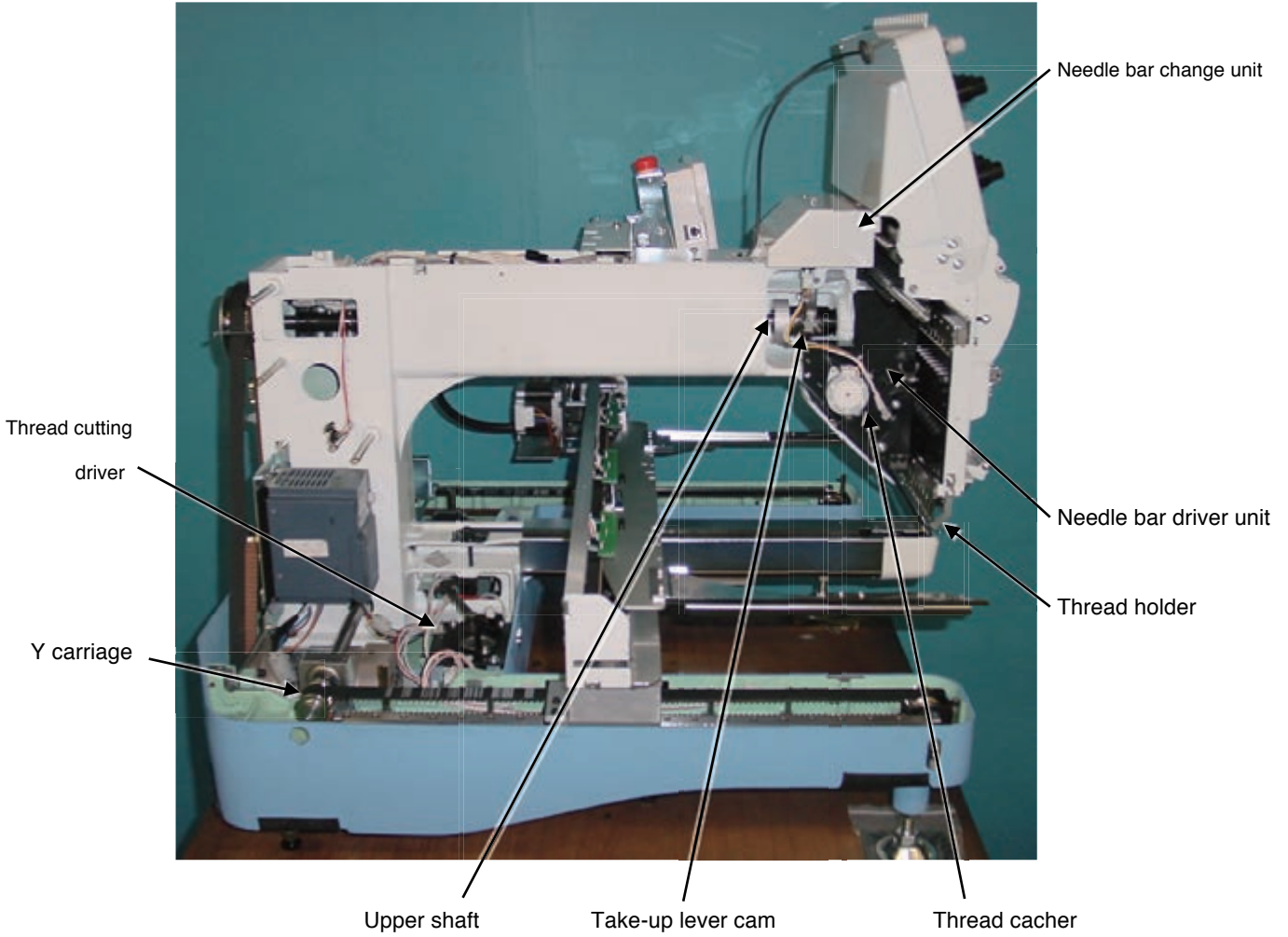

1-2 Placement of key electronic parts

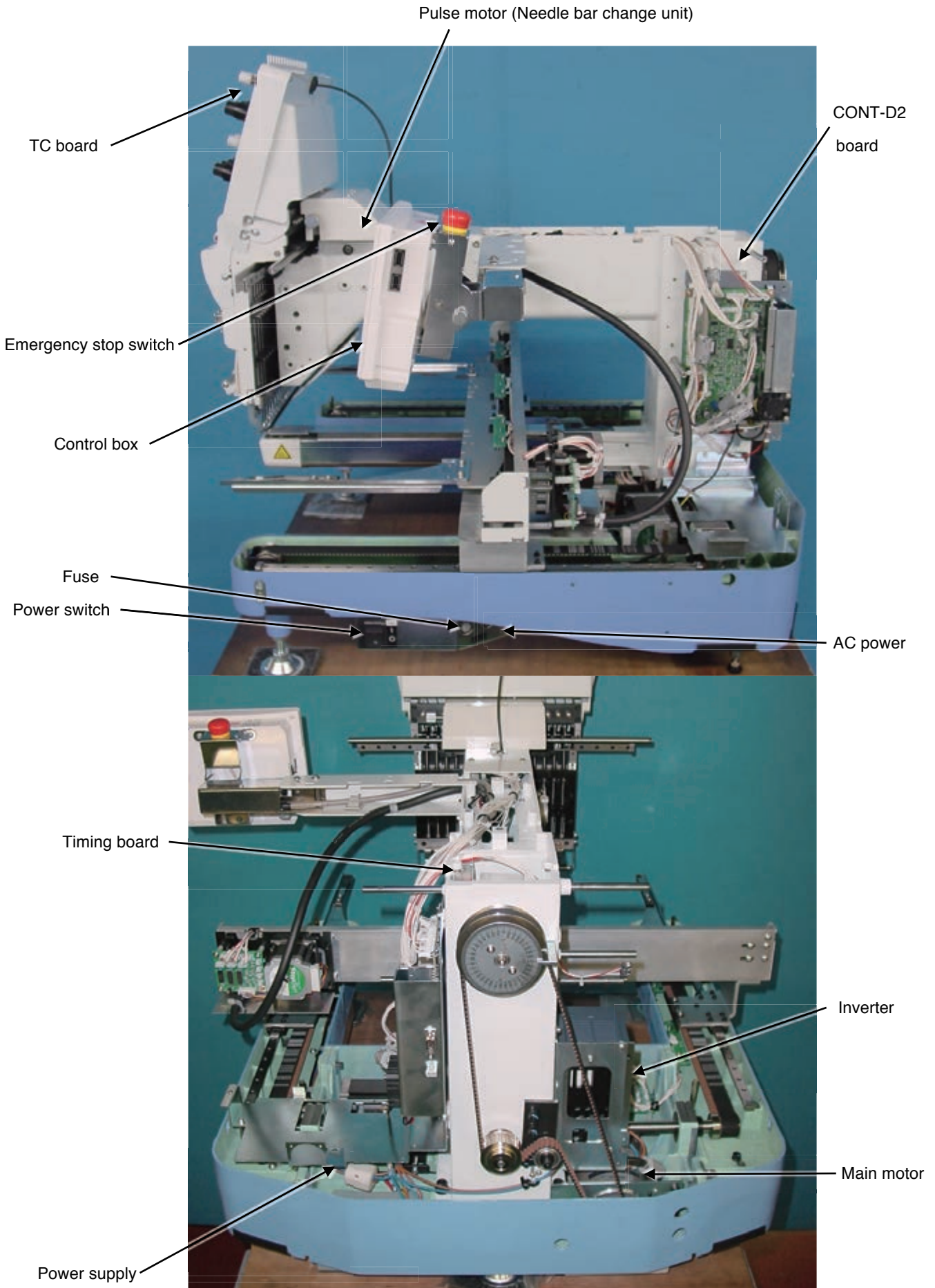

2-1 Removal of thread guide ass'y, thread guide pillar and thread stand

1. Remove all the tube holders from thread tension.

Tube holders are removed by pulling the tube holder upward.

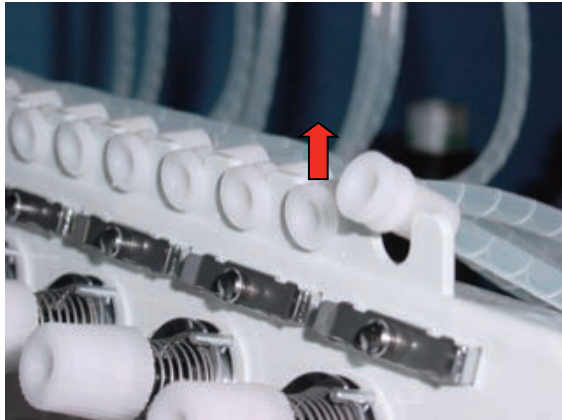

2. Remove 2 fixing screws and thread guide bracket.

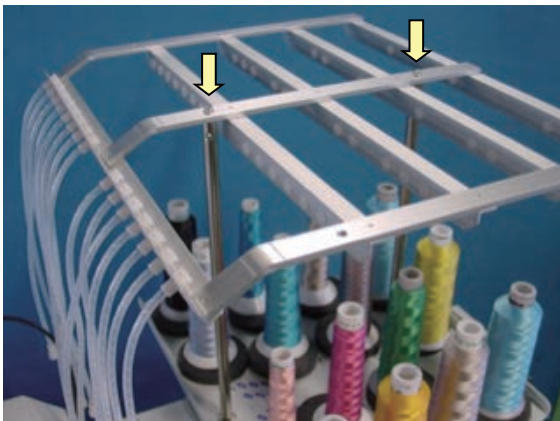

3. Remove thread guide pillar and thread stand.



4. Remove 8 fixing screws and thread stand.



2-2 Removal of outer covers

1. Remove the cover G ass'y. (Fixing screw 4 pcs)



2. Remove the cover E. (Fixing screw 2 pcs)



3. Remove the cover F. (Fixing screw 2 pcs)

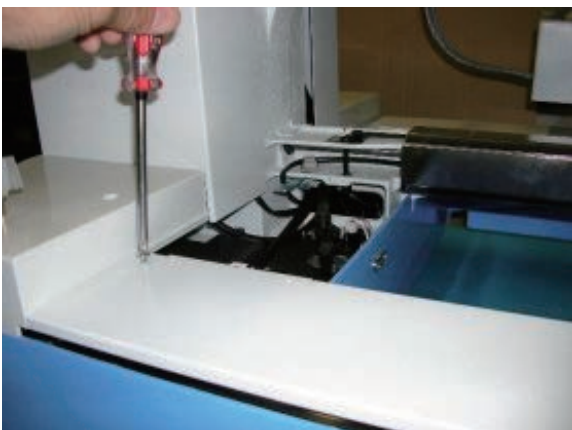

4. Remove the cover C. (Fixing screw 2 pcs)



5. Remove the cover H. (Fixing screw 6 pcs)



6. Remove the cover A. (Fixing screw 2 pcs)



7. Remove the cover D. (Fixing screw 2 pcs)

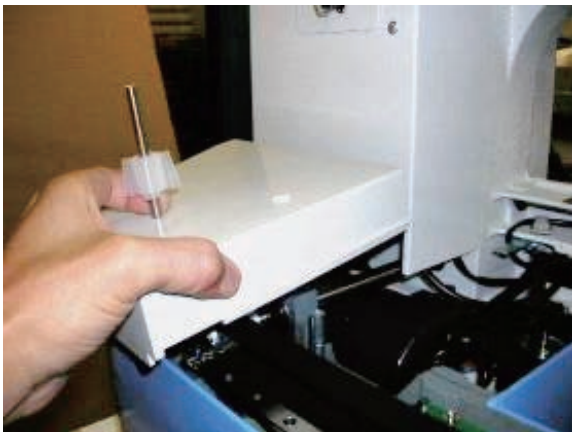

8. Guide should be removed if there is a bobbin winder.
(Fixing screw 1 pcs)



Remove the bobbin thread guide. (Fixing screw 2 pcs)



9. Remove the cover B. (Fixing screw 2 pcs)

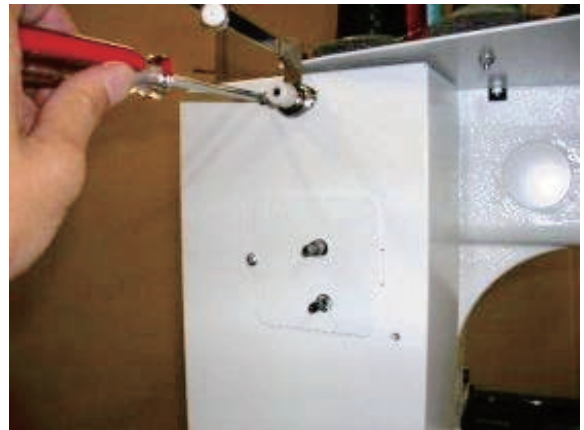

10. Remove the cover for needle bar change unit.
(Fixing screw 2 pcs)



11. Remove the head left side cover. (Fixing screw 2 pcs)



12. By above process, removal of [cover] has finished.

3-1-1 Maintenance of thread path

In a bid to prevent poor sewing finish or thread break, please keep places where thread contacts in the best condition.

1. Thread tension, detecting roller, thread adjusting spring

- a) Revolution must be smooth
- b) No sticking of lint or dust

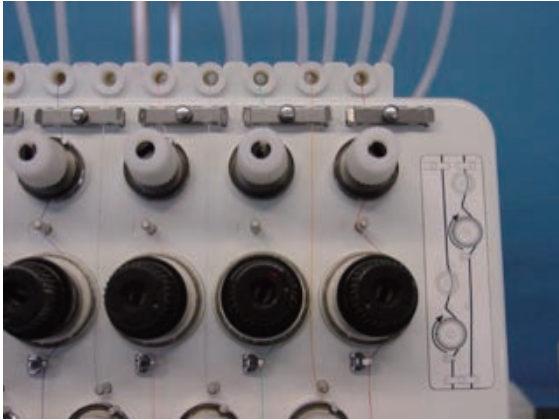

2. Thread Adjusting Spring, holes on thread guide plate

- a) No burr and crack

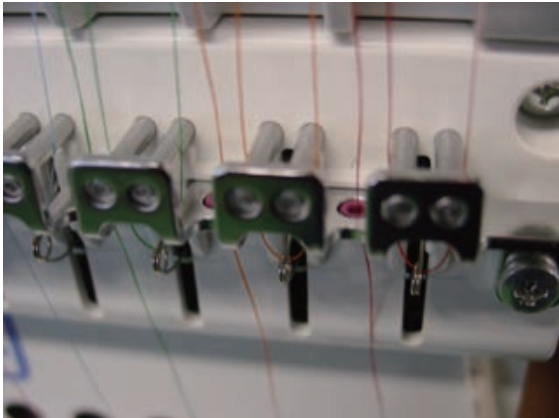

3. Ceramic and rim of take-up lever

- a) No burr and crack



4. Thread path in lower side and needle holder.

- a) No burr and crack



5. Needle

- a) Needle tip shouldn't be warped or bent.

When you slide needle tip on surface of nail and if the nail gets scratched.

needle tip is warped. Please exchange it with new one.



Please place needle on flat surface and check clearance (A) from side.

If clearance is not equal, needle is bent.

Please replace it with new one.

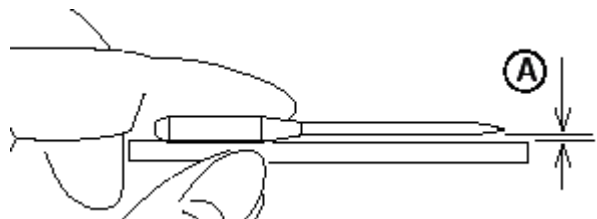

6. Needle plate

- a) No burr and crack in needle hole and around it.

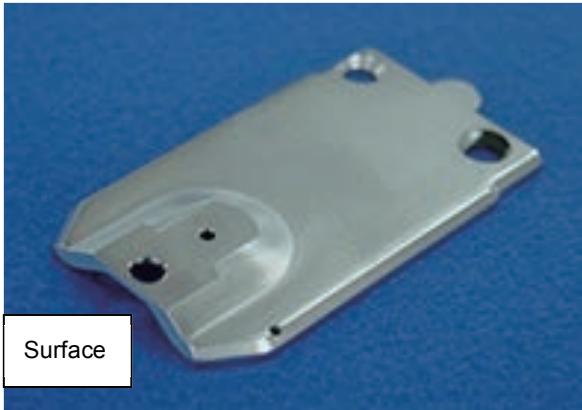

7. Pressure foot

- a) No burr and crack inside hole
- b) Not bent



8. Rotary hook

- a) No burr and crack.
- b) Hook point not warped.
- c) Backlash between bobbin case holder and outer hook should be less.



9. Keeper

- a) No burr and crack on tip.



3-1-2 Fixing of needle

1. In order of (1)-(4), please remove and fix needle.

- (1) Loosen screw holding needle.
- (2) Remove needle.
- (3) Insert needle till it goes to the end.
- (4) Tighten screw holding needle.

Fix needle so that needle groove faces front.

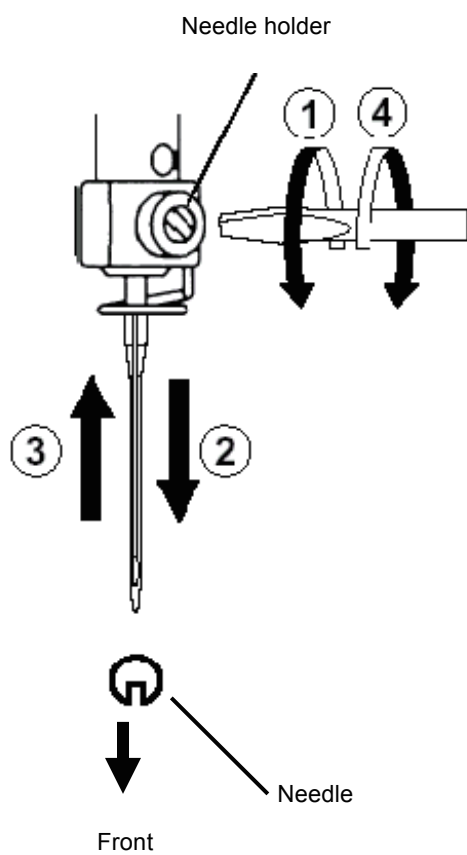

3-1-3 Selection of thread

1. Selection of upper thread.

<Description>

Please select considering cloth, design of pattern and flavor etc.

<Thickness>

Please refer to [Relation between needle and upper thread 3-1-4].

<Twist>

Z twisted thread is to be used.

(As rotary hook turns left- wise, Z twisted thread can prevent loosening of twist)



Z-twisted
(Left - twisted)



S-twisted
(Right - twisted)

2. Selection of lower thread.

Basically please use cotton thread (#80-120), #120 is recommendable.

Pay attention to the following in selection.

- # Thickness should be equal.
- # When it is lightly stretched, it doesn't break easily.
- # In process of time, it doesn't get inferior.

Commercially available paper bobbin can be used, but please select thread with thickness corresponding to cotton thread (#80-120).

3-1-4 Selection of thread

1. Description of needle

Basically please use [DB X K5] in standard accessory.

If description or thickness of cloth doesn't suit needle size, poor sewing finish / thread break / skipping will occur.

Therefore careful attention is required in selecting needle.

2. Relation between needle and upper thread will be found below. (Representative example is shown.)

Needle - Size is [German 75] in standard accessory.

If necessary, please select in accordance with description of thread and cloth.

Thread - In case needle size is [German 75], if thread is rayon, [#120] is recommendable.

Relation between needle and upper thread

Needle Size		Description of upper thread and thickness			
Organ	German	Cotton	Silk	Polyster	Rayon
8	60	100-130	140-160	150-200	50-70
9	65	70-80	100-120	130-150	70-100
10	70				
11	75	50-60	80-100	100-130	100-130
12	80				
13	85				
14	90	36-40	60-70	80-100	130-150
16	100	30-36	50-60	60-80	150-160
18	110	24-30	40-50	50-60	180-230

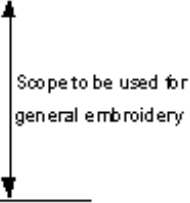

 Scope to be used for
 general embroidery

Denier (d)

If needle size and thickness of thread don't match, following problem will be likely to occur.

- Thread break
- Skipping
- Poor sewing finish

3-2-1 Exchange of crank ass'y

1. Referring to [3-3-1 Assemble and remove moving head], remove moving head.

2. Remove it by holding moving head up.

<Caution> Confirm that hook is apart from thread holder.



3. Remove thread catcher sensor cable, motor cable.

Remove thread catcher. (Fixing screw 2 pcs)

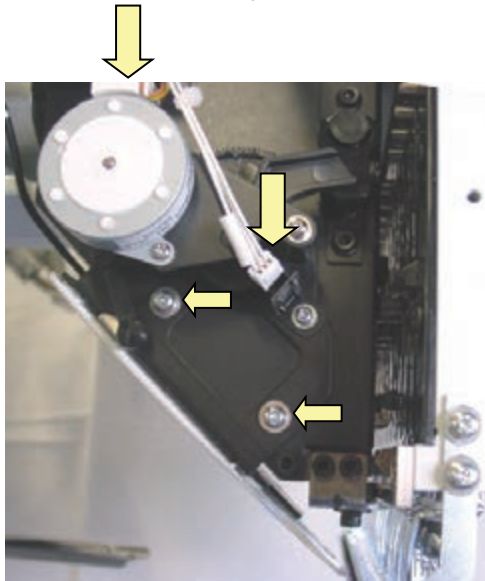

4. Remove face plate (left). (Fixing screw 2 pcs)

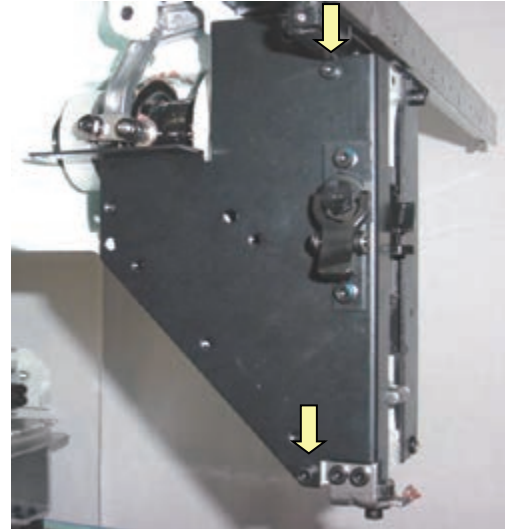

5. Remove face plate (right). (Fixing screw 2 pcs)

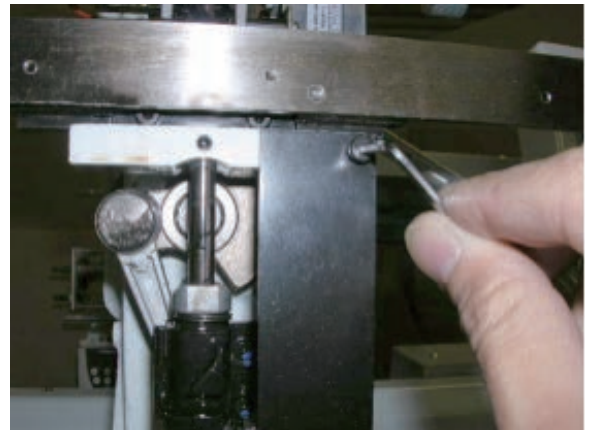

6. Remove upper rail. (Fixing screw 2 pcs)

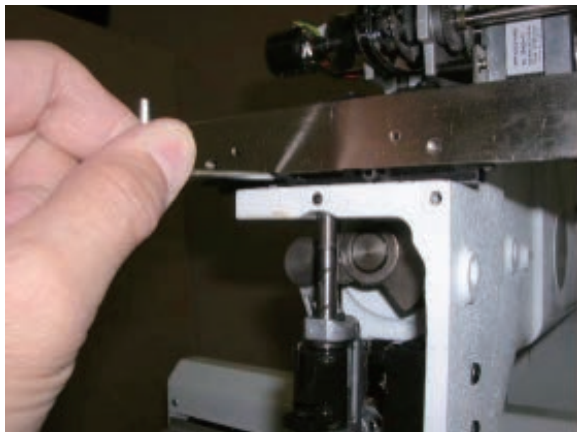

7. Remove head shaft. (Fixing screw 2 pcs)



<Caution>Head shaft should be taken off upward.



8. Remove needle bar driver ass'y.



9. Remove rod ass'y. (Fixing screw 2 pcs)



<Caution>Remove crank ass'y from guide rail.



10. Take off setscrew for bearing. (setscrew 2 pcs)

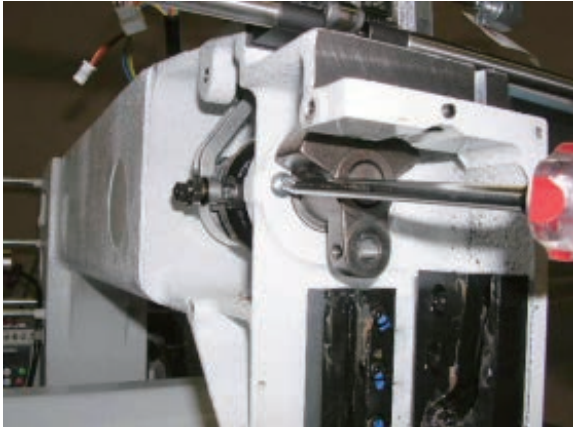

11. Remove take-up lever crank. (Fixing screw 1 pcs)

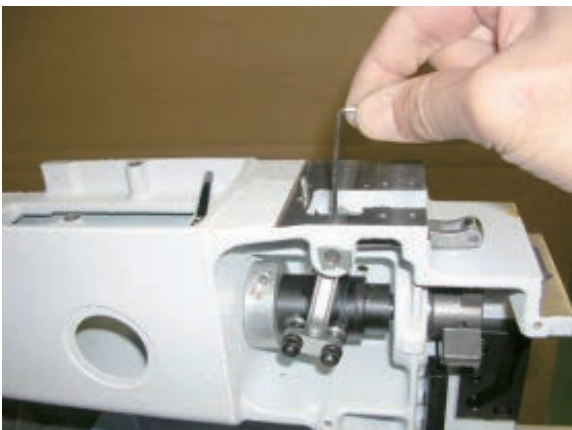

12. Pull out Take-up lever drive shaft and take off the crank ass'y.



13. Loosen the screw on fasten collar with barrel cam.



14. Loosen the screw on upper shaft collar.

(Fixing screw 2 pcs)

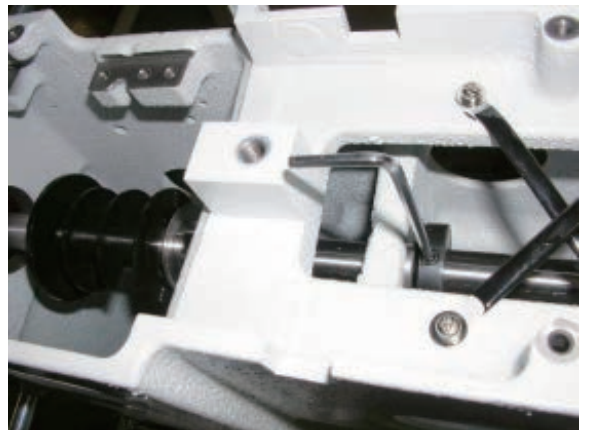

15. Remove timing detecting board. (Fixing screw 2 pcs)



16. Remove detecting board bracket. (Fixing screw 2 pcs)

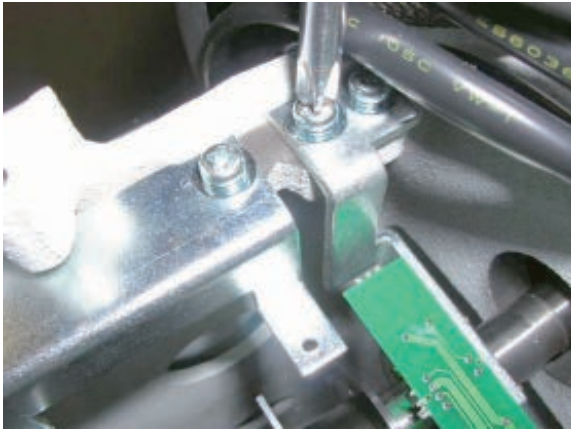

17. Loosen the screw on slit disc. (Fixing screw 1 pcs)

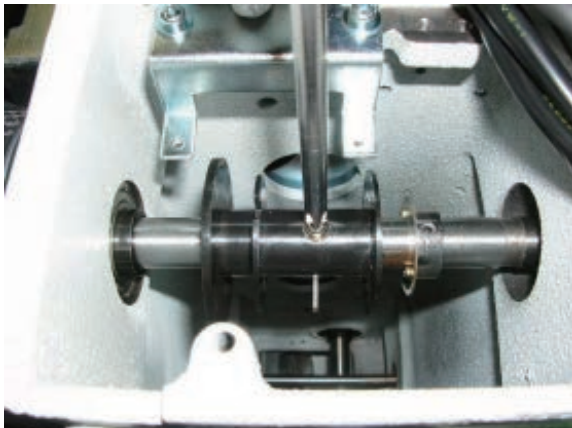

18. Loosen the screw on timing collar. (Fixing screw 1 pcs)



19. Loosen the screw on upper shaft collar.

(Fixing screw 2 pcs)

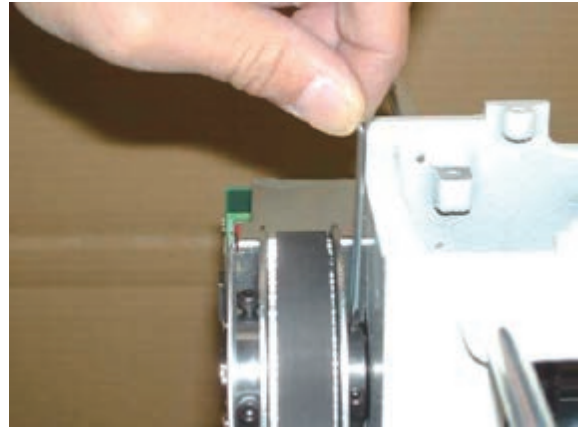

20. Loosen the screw on drive pulley (upper).

(Fixing screw 2 pcs)

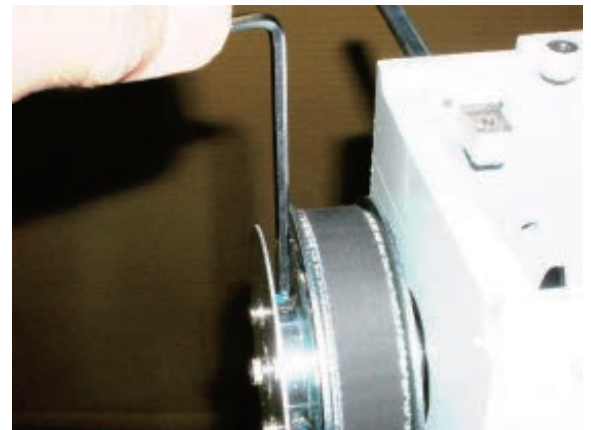

21. Remove pointer. (Fixing screw 1 pcs)



22. Check clearances between tension ass'y and tension block for 6.5mm to 7.0mm.

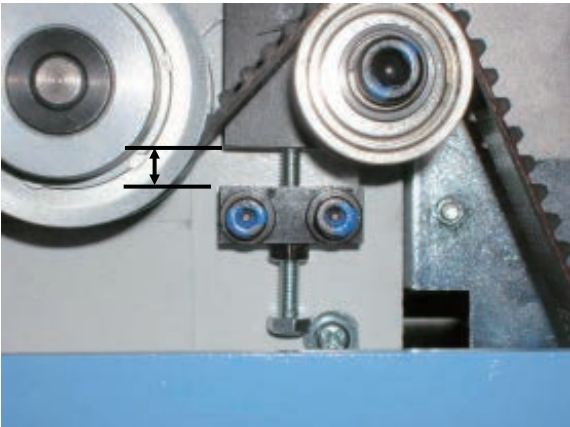

23. Loosen the screw on tension shaft ass'y.

(Fixing screw 2 pcs)

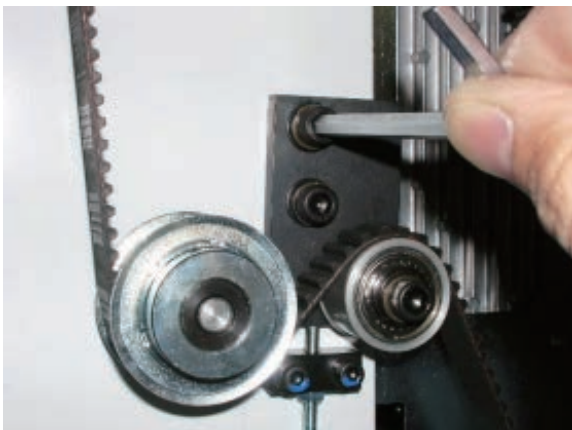

24. Loose fixing nut of tension block about 60 degrees.

<Spanner> 7mm

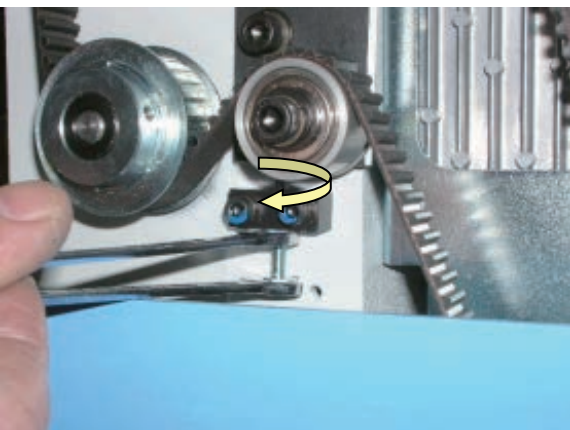

25. Loosed the adjusting bolt.

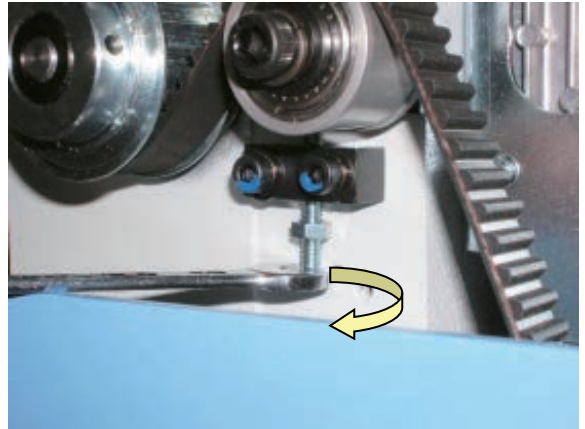

26. Take off the belt.

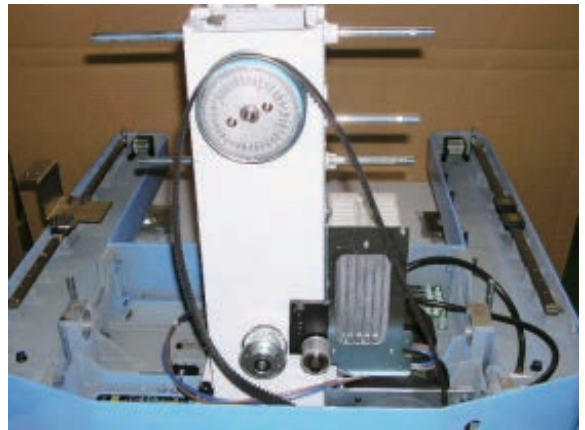

27. Remove drive pulley (upper).



28. Slide clank ass'y in upper shaft to front side of machine.

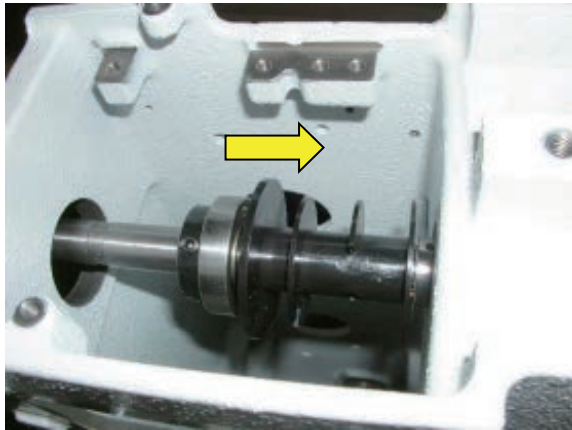

<Caution> Slide clank ass'y till touch to the machine body.

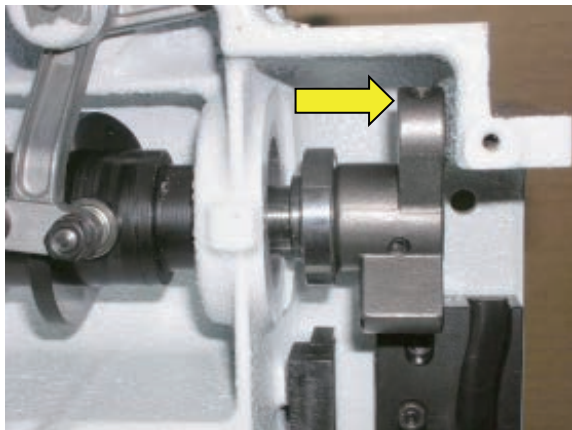

29. Turn clank ass'y to following picture position.
(Dose not touch clank ass'y to machine body at this position)



30. Please pull out cxlank Ass'y on upper shaft slowly.



31. Please slide and off upper shaft collar, slit, Timing slit and take up lever cam from Clank ass'y

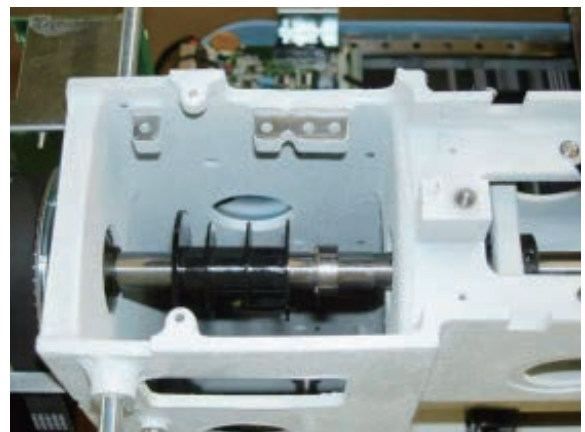

<Caution> Please care for some damage. because Timing slit is very thin and weak.



32. Remove crank ass'y.



35. Put parts once removed back in reverse order.

For adjusting fixing of each unit, please refer to process to adjust fixing of each unit.

<Important> Pay attention to following (1) - (4)

(1) Position of Upper shaft collar to same face bearing and bearing boss.

Center bearing

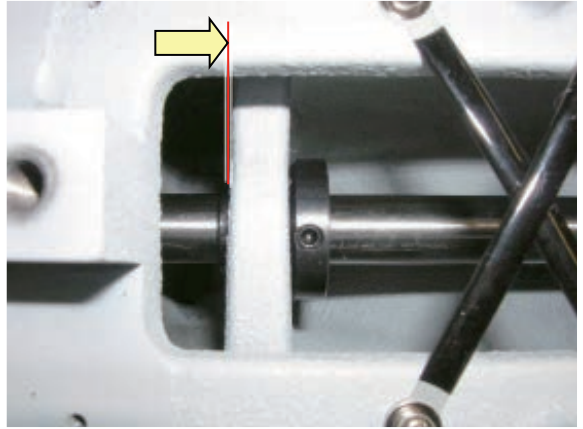

Rear bearing

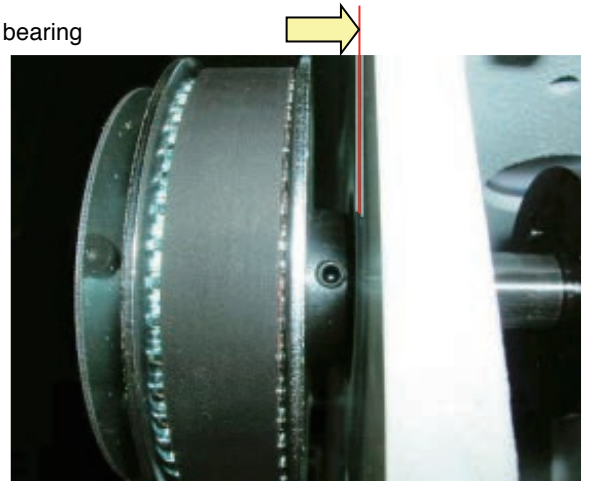

(2) Position of upper belt pulley.

Touch belt pulley to upper collar and fix screw to flat face on upper.

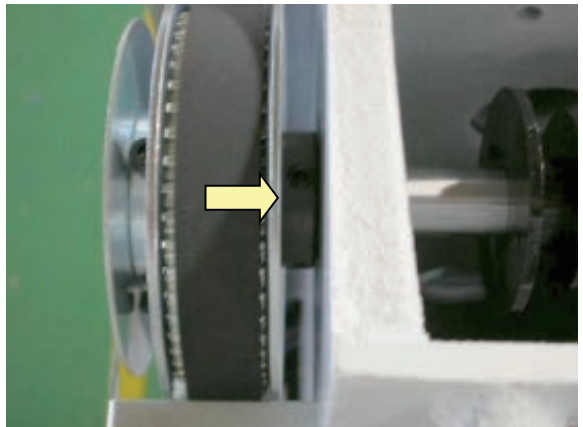

<Caution> Fix and tight setscrew to flat face on upper shaft.

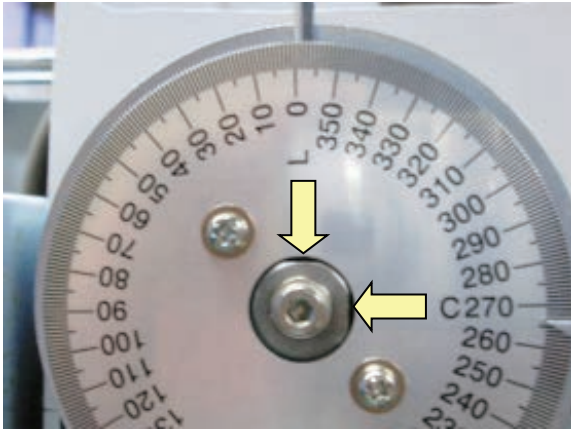

(3) Position of "Face plate (left)" close to rear and under side then fix screw.

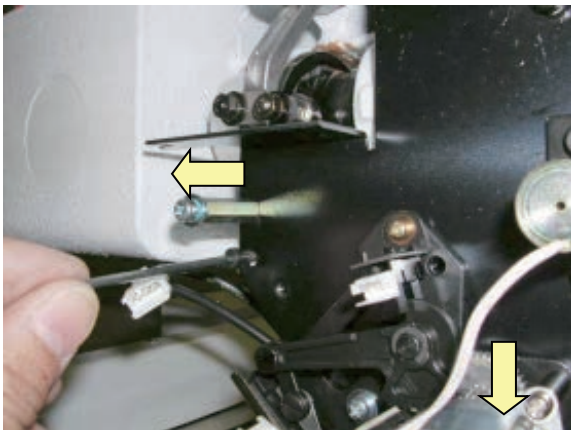

(4) Position of "Face plate (right)" close to left side then fix screw.

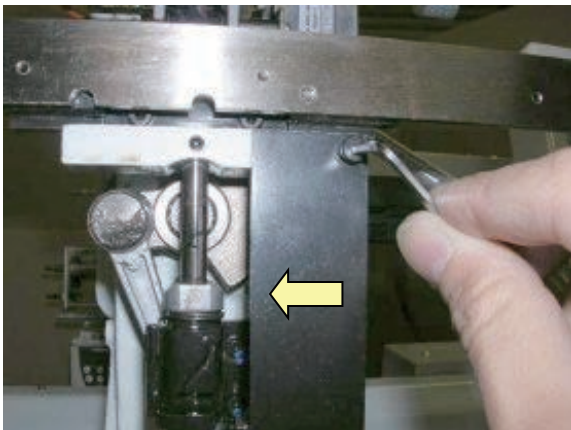

33. Please check and adjust the following timing to finish.

- (1) lowest needle point (Adjusting of pointer)
- (2) upper shaft timing (L point, C point)
- (3) Take-up lever timing
- (4) Shuttle hook timing
- (5) Thread cut timing
- (6) Fixing of jump solenoid

3-2-2 Exchange of rod

1. Referring to [3-2-1 Exchange of crank ass'y], remove moving head and thread catcher.

Moving head



Face plate (left)



Needle bar driver ass'y



2. Remove "Screw on crank pin" and take off "Rod ass'y".

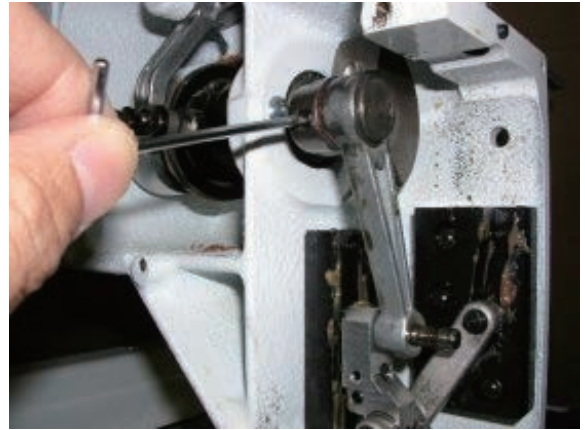

3. Take off rod from guide rail.



4. Loosen screw on rod. (Fixing screw 2 pcs)



5. Remove rod.

<Caution> The plastic thrust washer in crank ass'y.

Please care dose not lose.

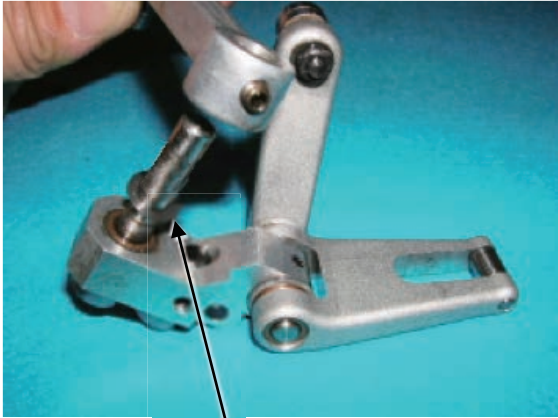

Plastic thrust washer

6. Install good parts.

At this time, put grease to bering of rod.

<Grease>[Shell alvania EP Grease](#) Equivalent brand.

(Shell Gudas S2 V220 2)

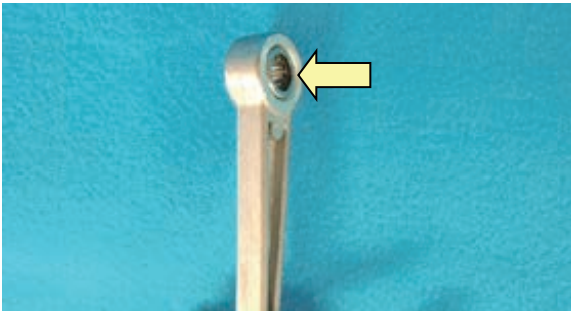

7. Put each unit back to where it was according to manual.

3-2-3 Exchange of pressure foot arm ass'y

1. Referring to [3-2-1 Exchange of crank ass'y], remove moving head, face plate (left), needle bar driver ass'y and Rod.

Moving head



Face plate (left)



Needle bar driver ass'y



Rod

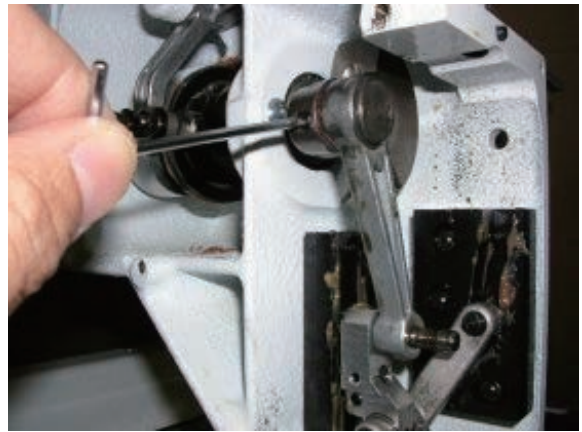

2. Remove pressure foot arm ass'y. (Fixing screw 2 pcs)



3. Install good parts.

<Caution> Please fix "Arm shaft" to even stick out from bush.

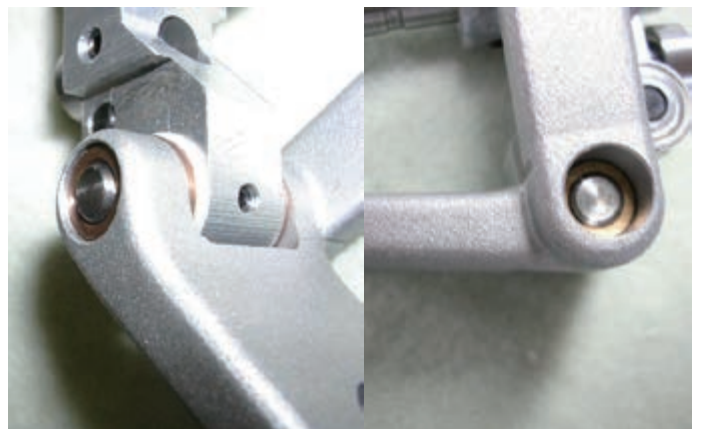

4. Put each unit back to where it was according to manual.

3-2-4 Exchange of pressure foot cam

1. Referring to [3-2-1 Exchange of crank ass'y], remove moving head, face plate (left), needle bar driver ass'y and Rod.

Moving head



Face plate (left)

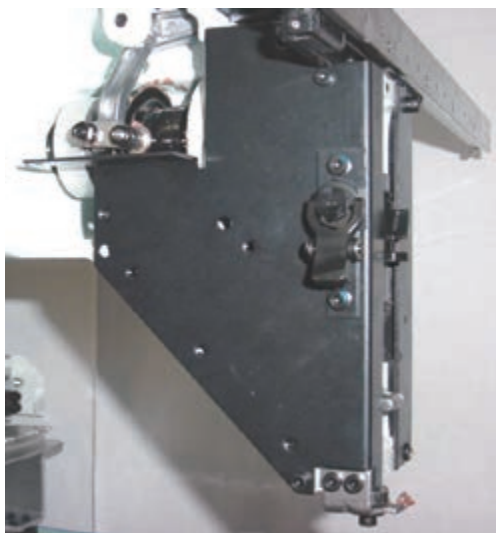

Needle bar driver ass'y



Rod



2. Remove pressure foot cam. (Fixing screw 3 pcs)



3. fix good parts as temporarily tight screw.

Please check bump 2mm between front of presser foot cam and front face of fixed head.

Put on grease to presser foot cam.

<Grease> [Shell alvania EP Grease](#) [Equivalent brand.](#)

(Shell Gudas S2 V220 2)

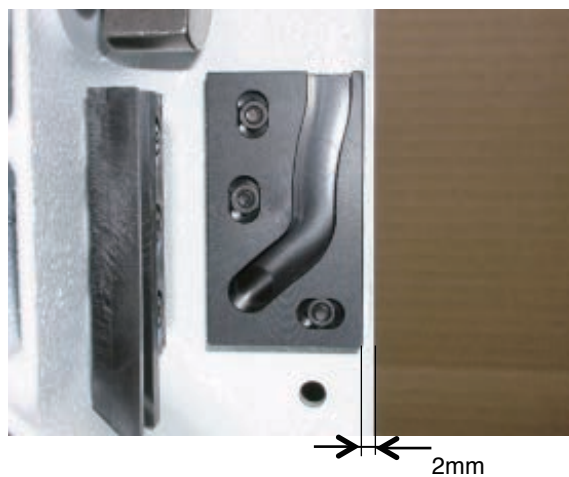

4. Install rod ass'y.

Should not have gap between a rod ass'y and washer.

Also rod should work smoothly.



In case has gap between a rod and washer, machine makes noise.

5. Set dial disc to [L + 0 degrees].

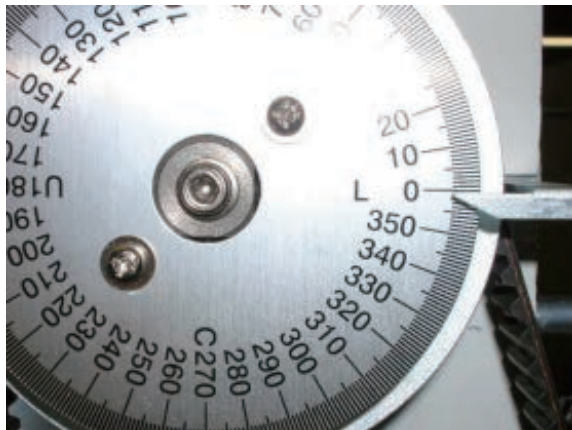

In this time, please check distance between upper face of presser foot and bottom face of fixed head to [25.5+/-0.2mm].

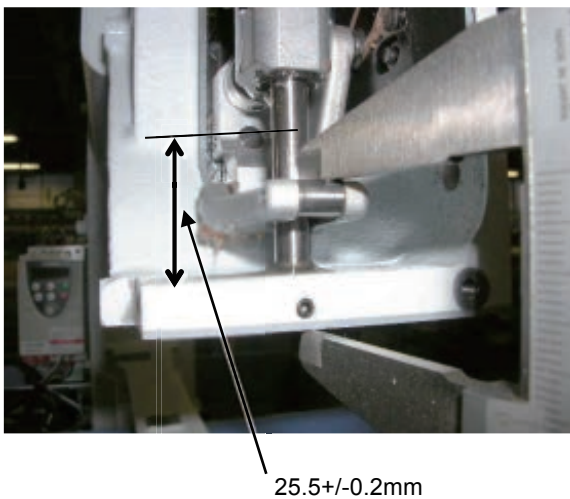

6. Set dial disc to [L + 60 degrees].

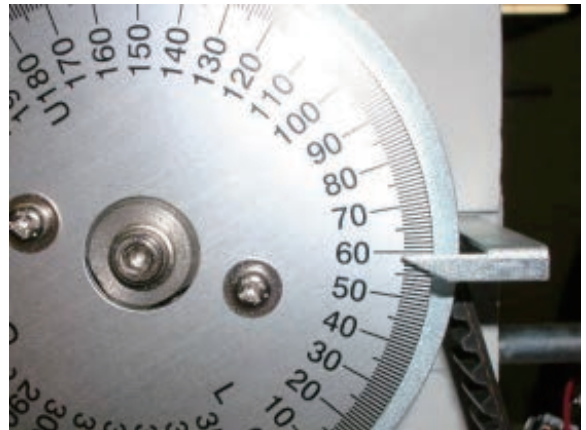

In this time, please check distance between upper face of presser foot and bottom face of fixed head to [26.1+/-0.2mm].



7. After check item 5 and 6 then tight screw completely for fix take-up lever cam.

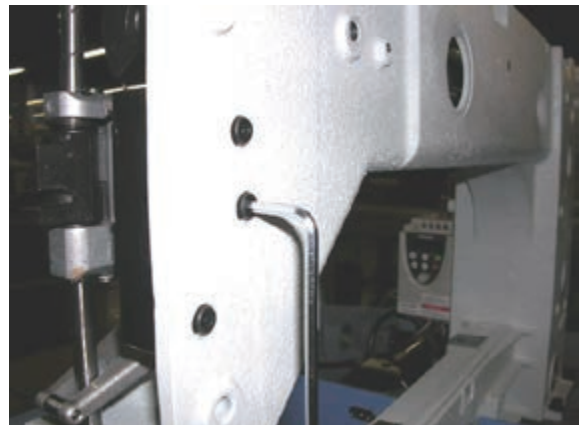

8. Put each unit back to where it was according to manual.

3-2-5 Adjustment of the lowest needle point

1. Turn upper shaft so that needle bar driver ass'y comes in the bottom.



In case there is moving head, bring needle bar to lowest point.



2. Please use dial gauge for strict checking.

Please see that timing on dial disc comes to [0 degree] when dial swings in highest value.



3. Please check indicator to [0 degree] completely.

In case of dose not match pointer and [0 degree line], please adjust pointer position to just on line.

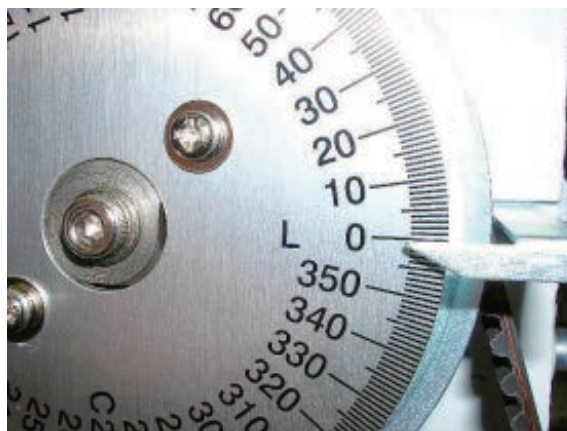

4. Referring to [3-8-4 Adjustment of detecting slit and timing slit], check timing and adjust, then finish this process.

5. Please check and adjust the following timing to finish.

- (1) Take-up lever timing
- (2) Shuttle hook timing
- (3) Thread cut timing
- (4) Fixing of jump solenoid

3-2-6 Exchange of needle bar driver

1. Referring to [3-2-1 Exchange of crank ass'y], remove moving head, face plate (left) and needle bar driver ass'y.

Moving head



Face plate (left)



Needle bar driver ass'y



2. Install good parts.

At this time, put grease to groove of rod shaft.

<Grease> Shell alvania EP Grease Equivalent brand.

(Shell Gudas S2 V220 2)

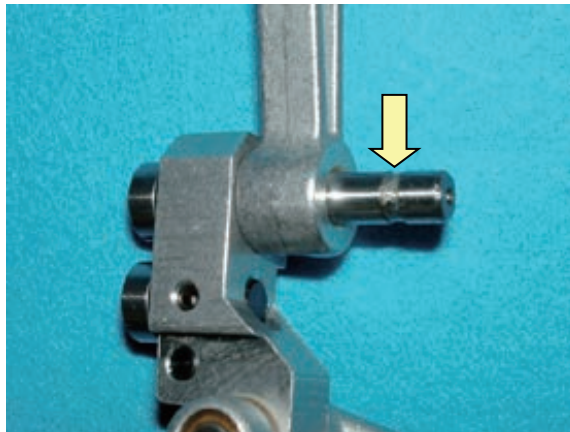

3. Put each unit back to where it was according to manual.

<Caution> Please fix top of head shaft position lower than ditch of oiling.

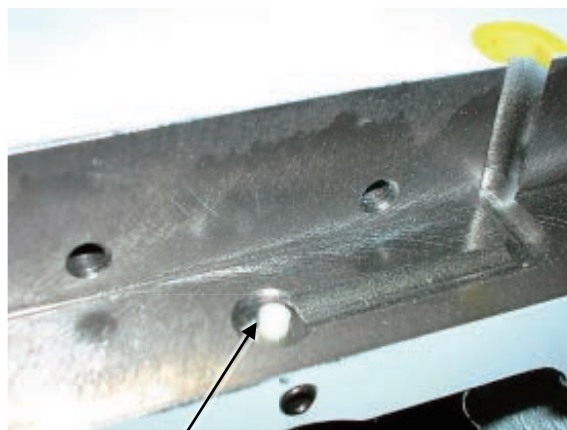

Top of head shaft

3-2-7 Adjustment of fixing of jump device

1. Referring to [3-3-1 Assemble and remove moving head], remove moving head.

Moving head



2. Move the rod of the contact and remove jump device.
(Fixing screw 2 pcs)

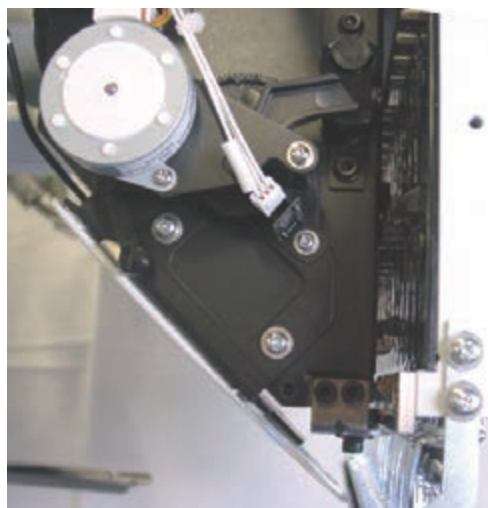

3. Install good parts.

4. Set upper shaft to [78 degrees] to adjust position of Jump shaft of jump device and Needle bar driver as illustrated below.



<Front view>

Viewing from front, Needle bar driver should come to center of Plunger.

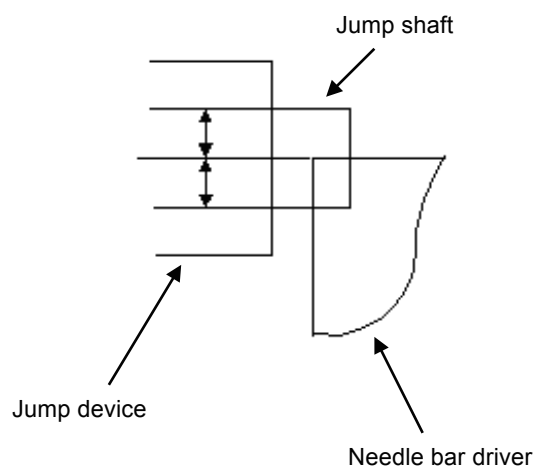

<View from left>

This shows a state that plunger and Needle bar driver contacts.

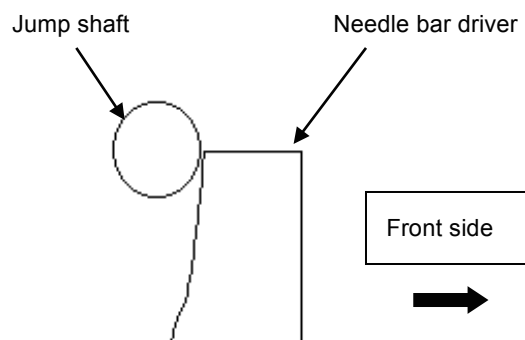

5. Please put parts back in reverse order to finish.
For adjustment of fixing of each unit, please refer to process to adjust fixing of each unit.

3-2-8 Exchange of roller shaft ass'y

1. Remove take-up lever crank ass'y.

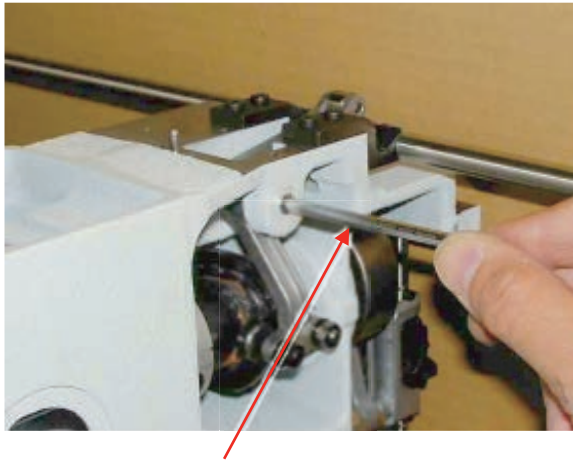
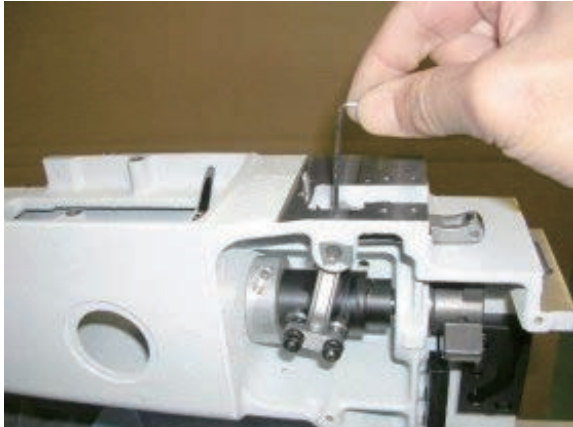

Push take-up lever drive shaft by slender shaft
(Hexagon wrench etc.)

2. Exchange roller shaft ass'y

<Spanner> 7mm, 8mm



3. Insert bearing positioning gauge [4.85mm] between bearing and bearing, and then tighten roller shaft ass'y.

Please adjust roller shaft for machine rear side ways.

This roller shaft ass'y is eccentricity.

Turn lean screw and just touch roller to gauge.

Bearing positioning gauge [4.85mm]

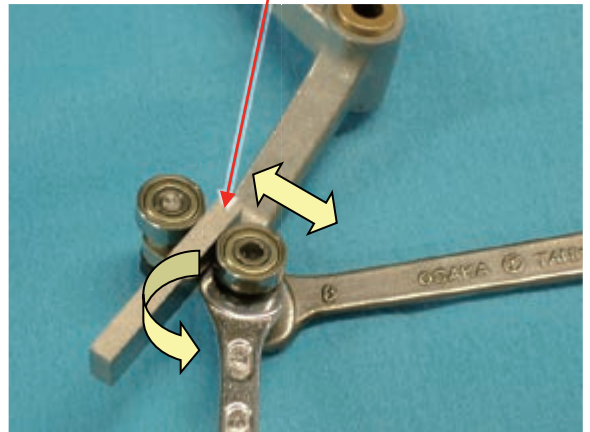

4. Return take-up lever crank ass'y to previous place to finish.

Should gap between chassis and take-up lever crank to 0.03mm.

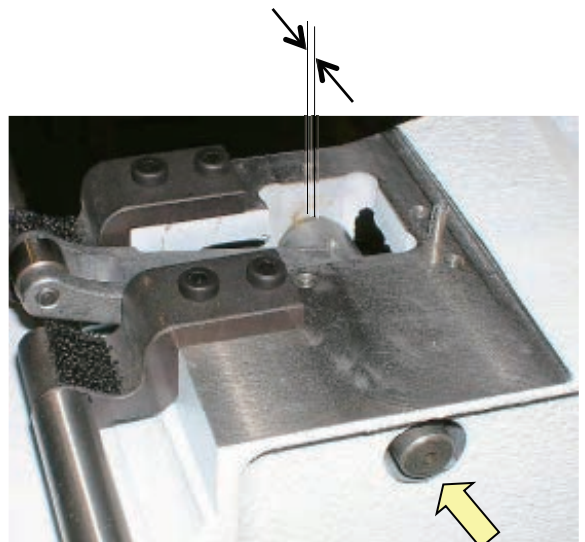

Please push to arrow ways.

< Check >

Please check non gap between roller and take-up lever cam on whole revolute main shaft.

3-2-9 Adjustment of take-up lever timing

1. Loosen screw on take up lever barrel cam.



2. Set dial disc to [0 degrees].

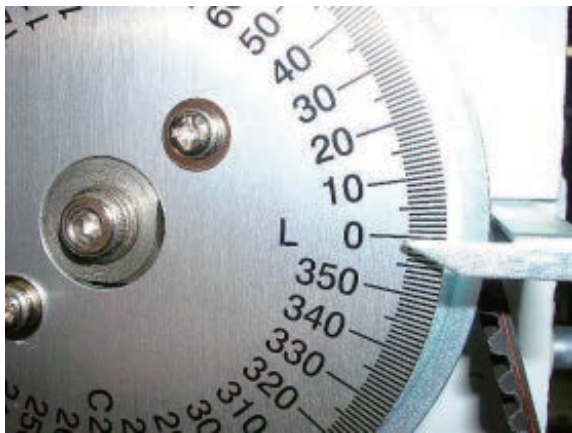

3. Insert positioning pin from right side.

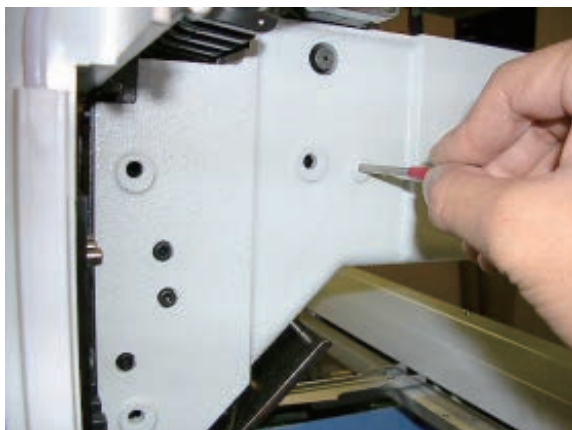

4. Turn take up lever barrel cam slowly and insert positioning pin into pin groove.

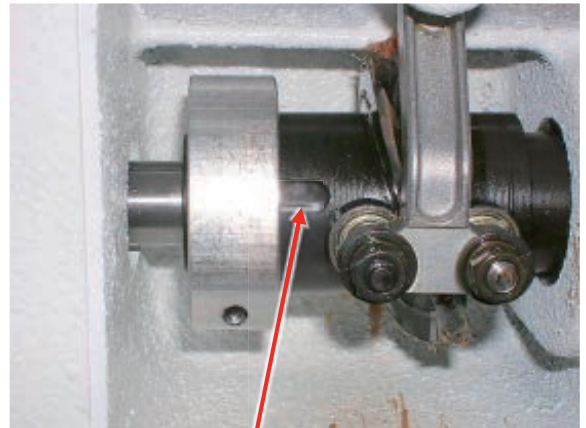

Pin groove

5. Tighten screw.

Please set position of slit on Fasten collar and Lever barrel cam.

<Important>

Rotate the Take up lever barrel cam clockwise until pin ditch touches to positioning pin then tighten the screw.
(No gap between take-up lever barrel cam and crank)

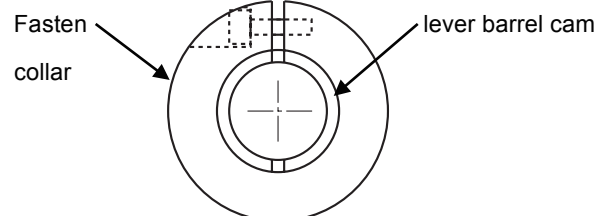
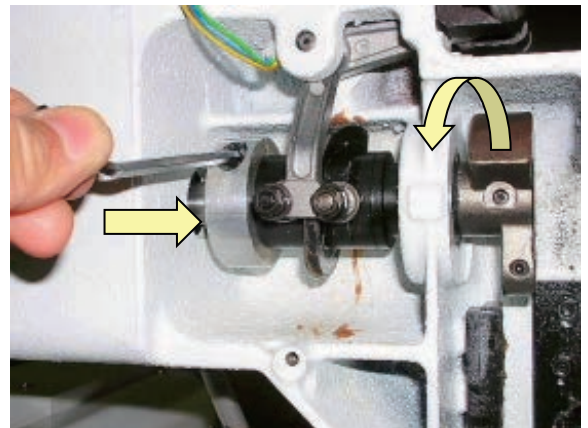

6. Pull out positioning pin.

7. Turn upper shaft and set dial disc to [C] to finish.

3-2-10 Check of height of pressure foot

1. Bring needle bar down.

Pick needle holder and down hardly.



2. Turn upper shaft and set dial disc to [0 degree].

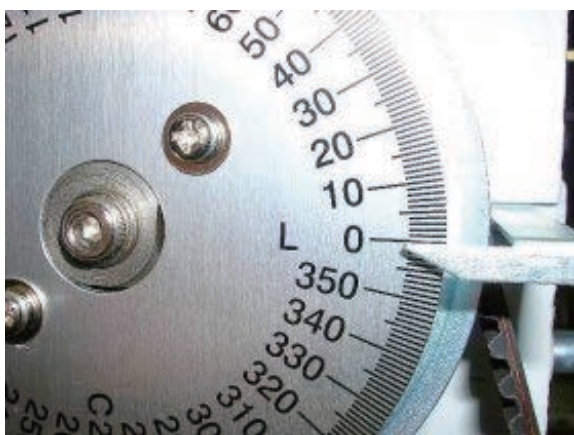

3. Insert [Gauge 1.2mm] between needle plate and pressure foot.

No gap between gauge and pressure foot or needle plate, will be OK.



4. If wrong space (not 1.2mm), please adjust height of pressure foot guide bar.

Please refer to [3-2-11 Exchange and Adjustment of pressure foot].

3-2-11 Exchange and Adjustment of pressure foot

1. Remove lower front panel. (Fixing screw 2 pcs)



2. Remove needle, needle holder and cushion.

<Caution> Please care when remove Needle holder, pop down Pressure foot.



3. Remove pressure foot. (Fixing screw 1 pcs)



4. Install good parts.



5. Please set needle and needle clamp.

For set needle, please reference [3-1-2 Fixing of needle].

6. Adjust needle height.

Please refer to [3-3-6 Adjustment of needle height].

7. Bring needle bar down.



8. Turn upper shaft and set dial disc to [0 degree].

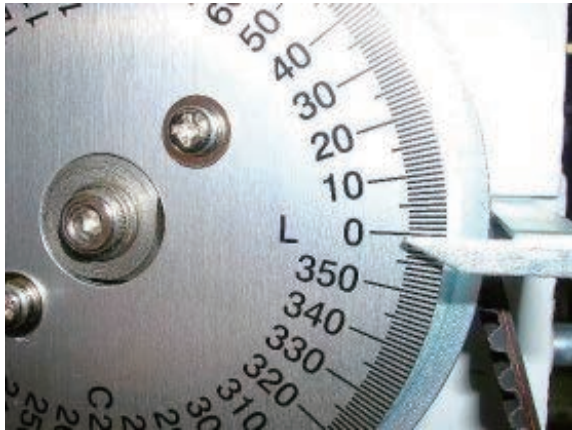

9. Insert [Gauge 1.2mm] between needle plate and pressure foot.

1.2 mm is standard, But please adjust depends by thick of material.



10. Tighten fixing screw for pressure foot.

(Fixing screw 1 pcs)

At this moment, no gap between gauge and pressure foot or needle plate.



11. Return lower front panel to previous places to finish.

3-2-12 Fixing of thread catcher

1. Install thread catcher tentatively by tightening screws.

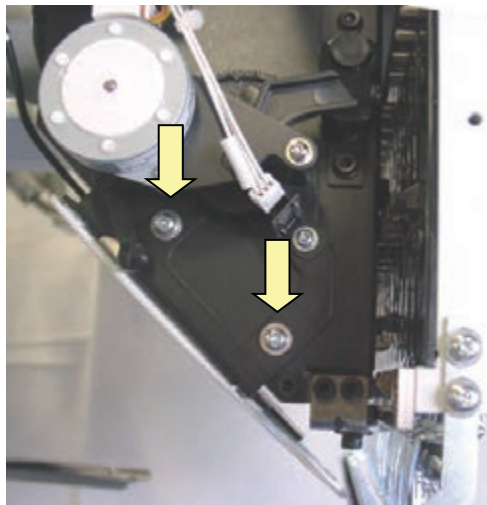

2. Loosen screw of sensor for thread catcher unit a little bit.

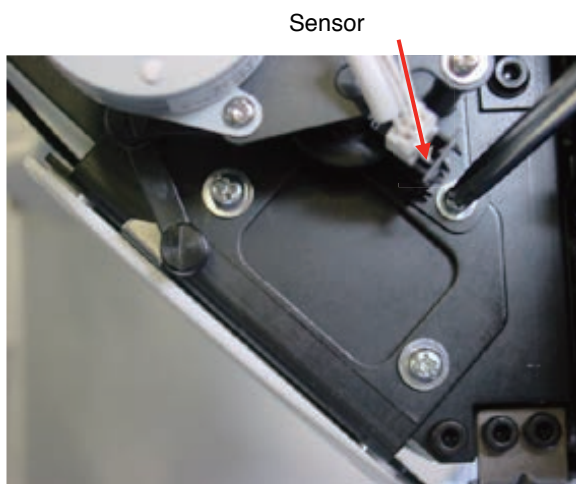

3. Refer to "9-1 How to enter maintenance mode" and enter maintenance mode.

4. Press **Machine Test**.

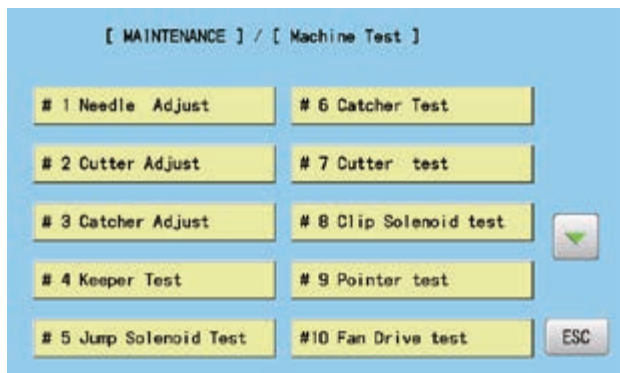

5. Press **Catcher Adjust**, take thread catcher unit in and out, and move and adjust the sensor shown in the direction of the arrow so that the dimension in the following figure meets the value in the following figure when hook goes back. Fix the sensor with setscrew after adjustment.

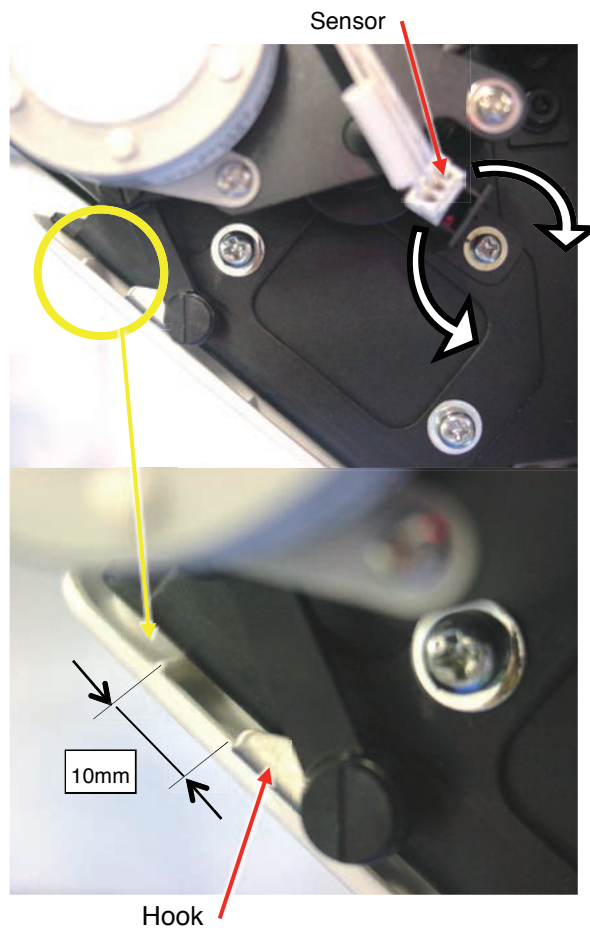

6. Tighten the screws securely while pushing thread catcher unit in the direction of the arrows of the following figure to fix the unit.

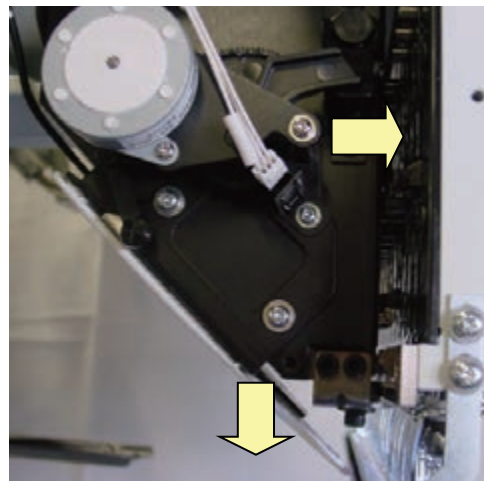

7. Continue to “Adjustment of thread holder”.

When you adjust thread holder, you might need to adjust thread catcher unit again.

Follow the procedure in “3-3-10 Adjustment of thread holder.”

3-3-1 Assemble and remove moving head

1.. Remove Take-up lever cover. (Fixing screw 2 pcs)

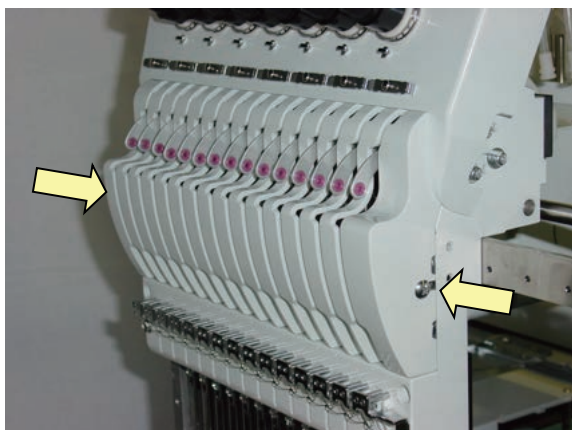

2. Remove Tension rear cover. (Fixing screw 4 pcs)

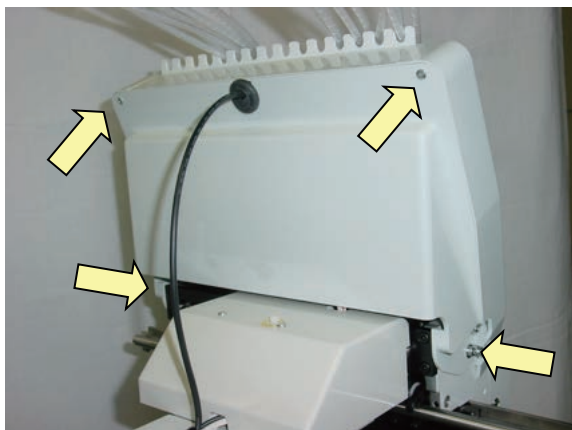

3. Remove TC sensor cable and Front LED cable.

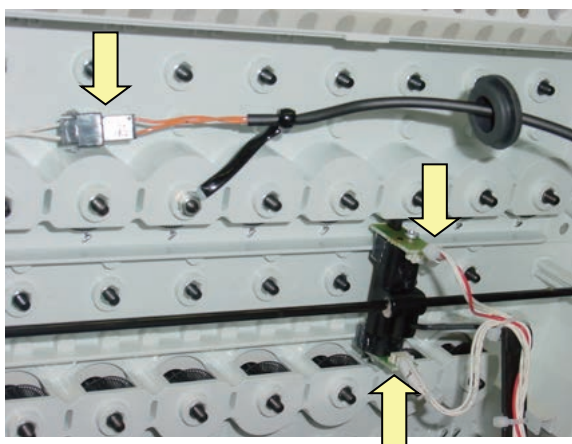

4.. Remove moving head. (Fixing screw 4 pcs)

<Caution> For back on moving head latter, please note needle number when you take off moving head.



5. Remove it by holding moving head up.

<Caution> Confirm that hook is apart from thread holder.



6. place a moving head on the thread guide.



.Moving head removing has finished.

7. Install moving head tentatively.

<Caution> Please back on moving head to same needle position when you take off moving head.



<Caution> Two type of setscrews.

Please check length of screw

<Caution> Please put plain washer with hexagon socket head cap screw.

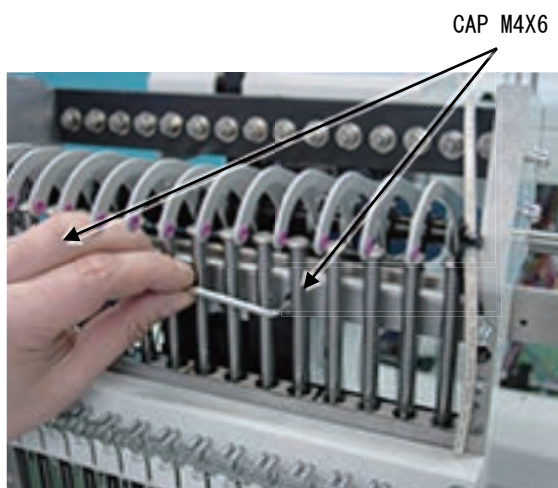
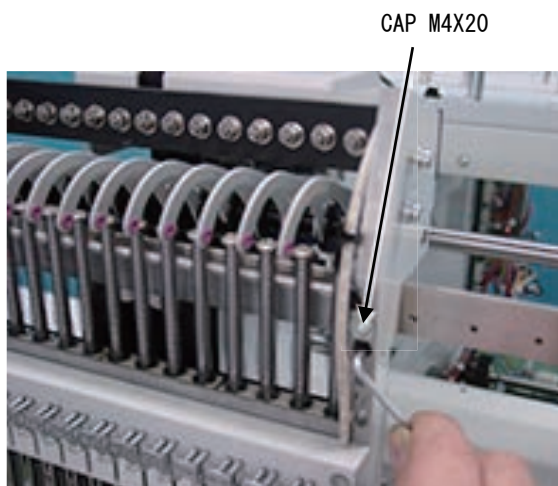

8. Please check NO gap between "Moving head" and "Rail support".

You can check from side of moving head.

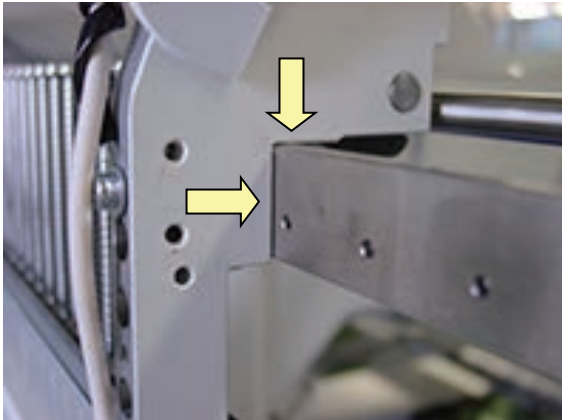

9. Check center (right and left)(back and forth) of needle and needle hole of needle plate.(Needle No.1 ,8 and 15.)

<Caution>

Should be check needle No.1 ,8 and 15.

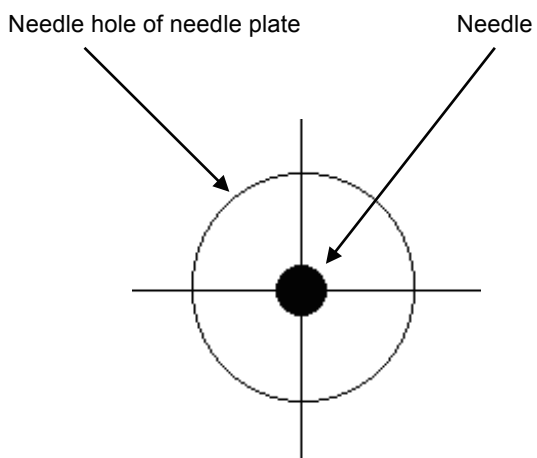

10. If not center (back and forth),please adjust needle position (back and forth).

Refer to [3-3-4 Adjustment of needle position (back and forth)].

11. If "OK". Please check [needle position].

Refer to [3-3-5 Check of needle position].

3-3-2 Fixing of upper rail

1. Slide "Rail support" on "Upper rail ass'y" to center of fixed head and tight back screws.

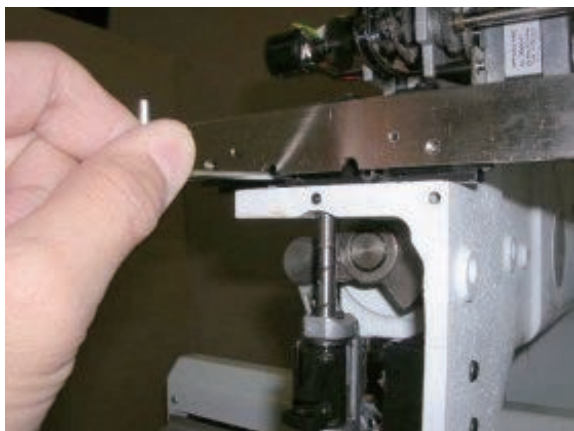

<Caution>

Please push and close rail to following narrow direction then tight screws.

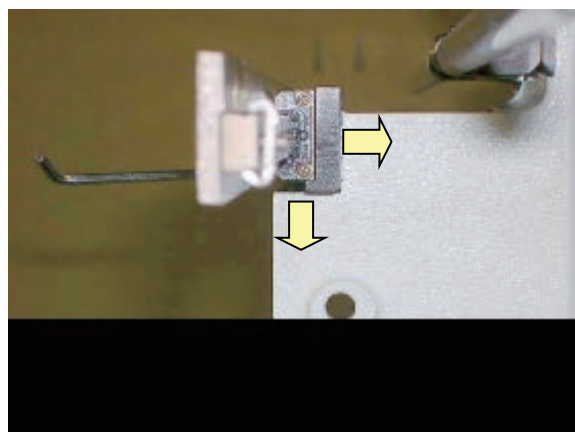

2. Fixing has finished.

3-3-3 Adjustment of backlash (back and forth) of moving head

1. Adjust positioning roller shaft so as to put moving rail (lower) between bearings.

Move moving head back and forth so as not to cause backlash.



2. After adjustment, check and adjust needle drop to finish
Please refer to [3-3-4 Adjustment of needle position
(back and forth)].

3-3-4 Adjustment of needle position (back and forth)

1. Bring needle bar down.



2. Turn upper shaft and set needle near to the lowest needle position [L] to adjust positioning plate ass'y.

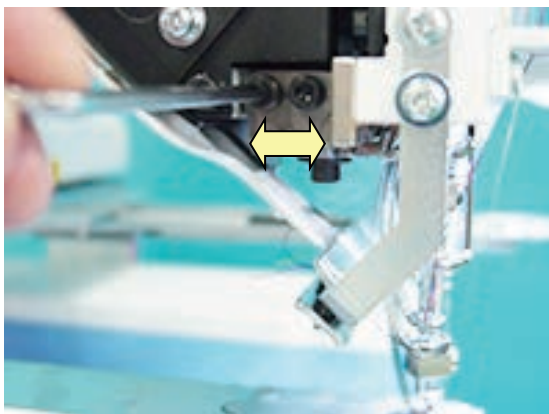

Viewing from side, set to center of needle hole.

#Check and adjust with 1st, 8th and 15th needle.



3. After adjustment, please be sure to check and adjust clearance between needle and shuttle hook.

Please refer to [3-5-1 Adjustment of rotary hook timing].

* Insert Lower rail to between the two bearing deeply.

(This is for setting of Moving head completely.)

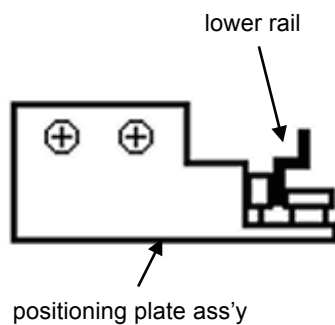

3-3-5 Check of needle position

1. Slide moving head to 8th needle.

2. Stick a seal on needle hole of a needle plate.



3. Bring needle bar down.



4. Turn an upper axis up to [298 degrees – 300 °], and it is the needle mark to a seal. A hole is made.

<Note>

Needle point will become large if the angle of a dial disc is made into 301 degrees or more.

An exact needle position check becomes impossible.



5. Reverse-rotate an upper axis, raise a needle bar, and unite with C [270 degrees].

(It returns to 300 degrees-> 230°, and unites with 270 degrees after that.)

<Note>

If a top axis is right-rotated, a needle will enter deeply, and needle hole is greatly.

It becomes. Therefore, an exact needle position check becomes impossible.

6. 1st needle and the 15th needles are to 298 degrees - 300 degrees about an upper axis by the above-mentioned procedure. It turns, a needle is lowered and a needle position is checked.

It will be O.K. if the needle point goes into the seal hole made by the 8th needles at this time.

7. Un-stick a seal on needle plate to finish.

3-3-6 Adjustment of needle height

1. At this time, lower front panel. (Fixing screw 2 pcs)



2. Remove bobbin case.



3. Bring needle bar down.



5. Turn upper shaft to set dial disc to [L + 5 degrees].



6. Loosen screw on needle bar boss.

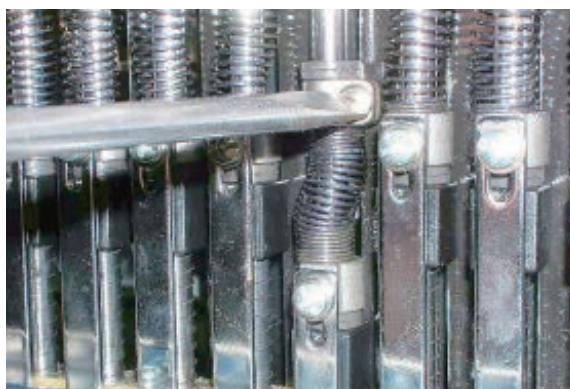

6. Put needle height gauge in rotary hook.



7. Adjust the needle bar height up and down till the needle tip touches to the gauge slightly.



9. Tighten the screw of needle bar boss.

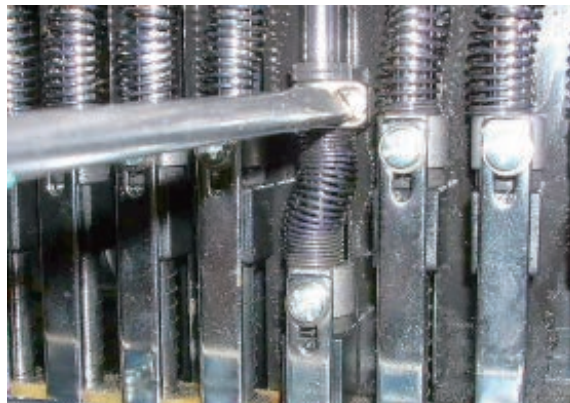

9. Set direction of needle stop as illustrated below.



10. Produce "Needle height gauge" from hook.

11. Back main shaft to [270 degree] position.

12. Set "Lower front panel" and "bobbin case" then end of process.

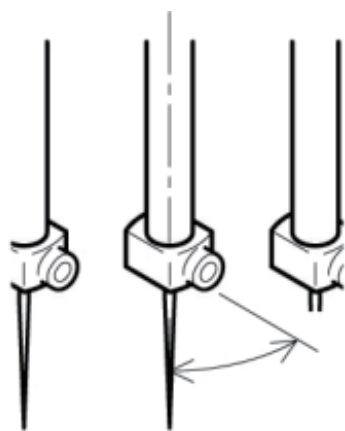

About 30 degrees

3-3-7 Exchange of needle bar, needle bar spring, cushion and pressure foot block

1. Referring to [3-2-11 Exchange of pressure foot], remove pressure foot.



2. Loosen screw on needle bar boss.

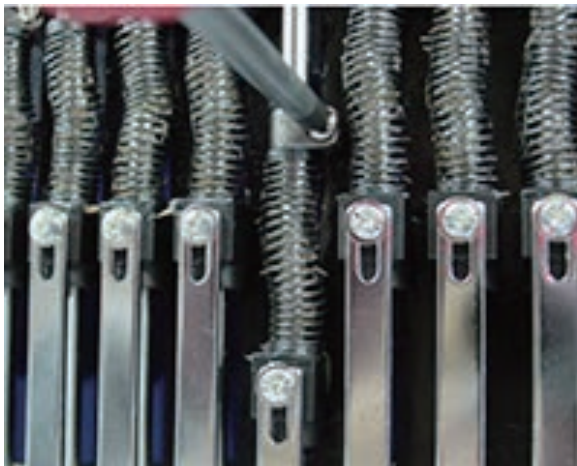

3. Take off "Needle bar boss".

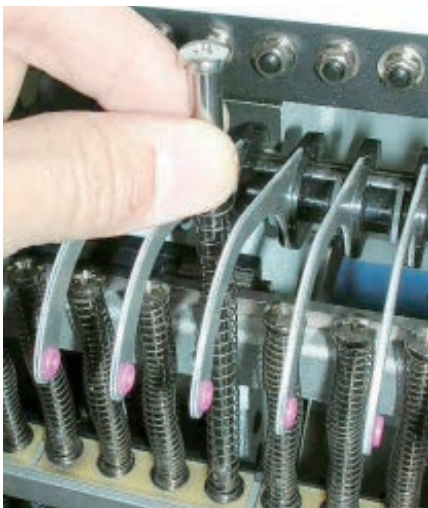

At this time, remove pressure foot spring (lower), pressure foot block, cushion and needle bar boss.

4. Set good parts to needle bar.

At this time, if insert extra needle bar from under, you can work more easily.

<Caution> Care to insert direction for "Pressure foot" and "Pressure foot boss".

Pressure foot block

Check shape of direction.



Cushion



Needle bar boss



5. Fix needle bar spring.

Finally, push upper needle bar and string all parts then pull out lower extra needle bar.

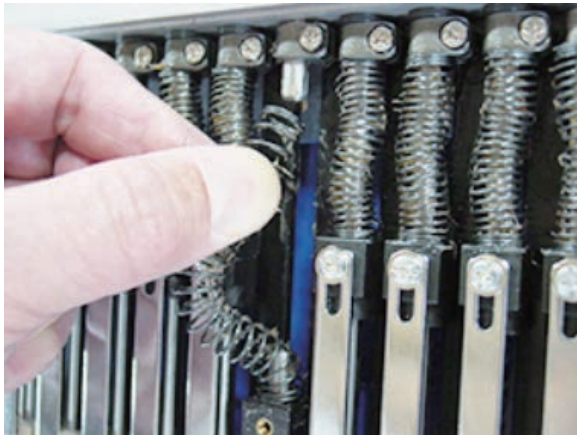

Slide needle bar to lower.

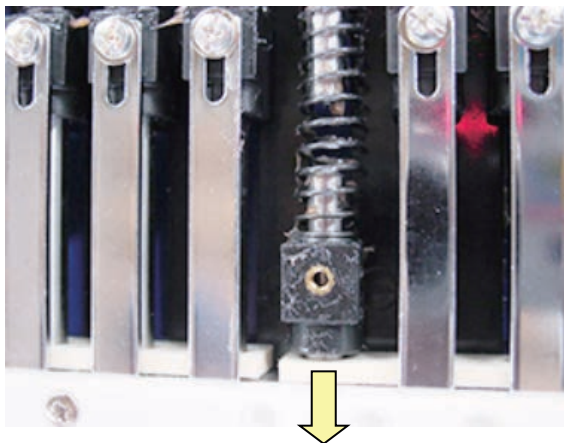

6. Fix pressure foot.



7. Fix needle, needle holder and cushion.



8. Adjust needle height.

Please refer to [3-3-6 Adjustment of needle height].

9. Adjust pressure foot height.

Please refer to [3-2-11 Exchange / Adjustment of pressure Foot].

10. Put removed parts back to finish.

3-3-8 Fixing of needle bar boss check plate

1. Remove moving head.

Please refer to [3-2-1 Exchange of crank ass'y].



2. Exchange of needle bar boss check plate.

3. Temporarily, use the pan head screw to center the needle bar boss check plate then fix the screw

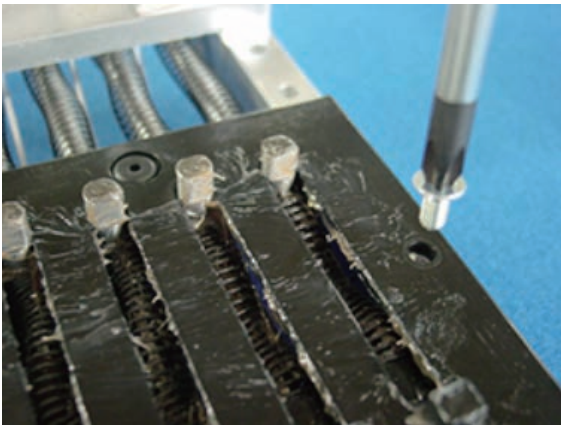

4. Fix positioning needle bar boss check plate.

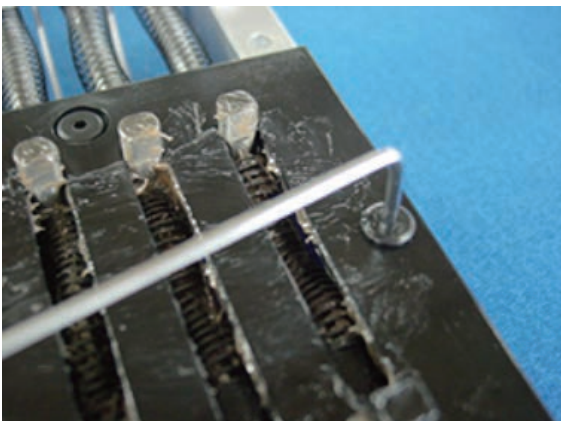

5. Put moving head and other removed parts back to finish.

3-3-9 Exchange of take-up lever

1. Remove moving head.

Please refer to [3-3-1 Assemble and remove moving head].



2. Loosen screw on take-up lever shaft. (Fixing screw 2 pcs)

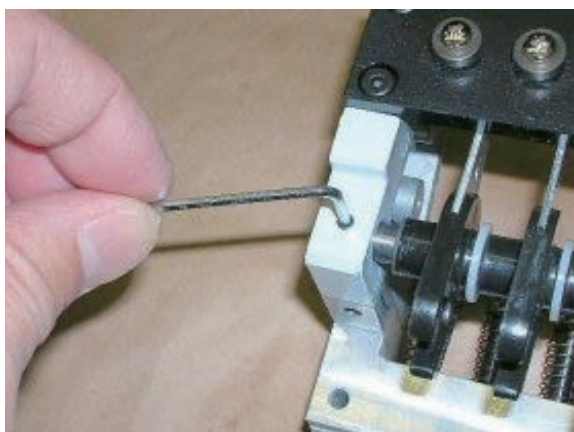

3. Remove the E-ring.

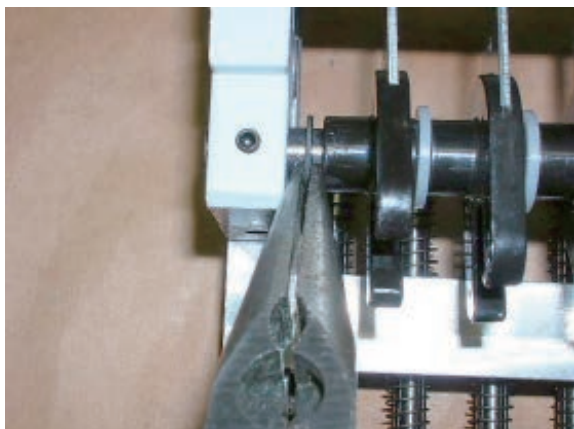

4. Please do not miss "Plastic thrust washer" between E-ring and Take up lever.

Remove plastic thrust washer. (1 pcs)

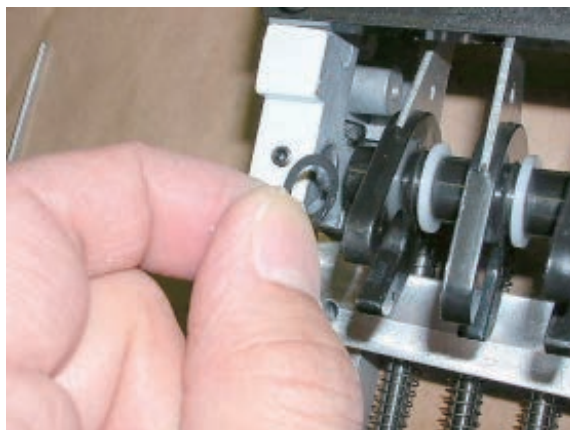

5. Remove the take up lever shaft first then remove the take-up lever.

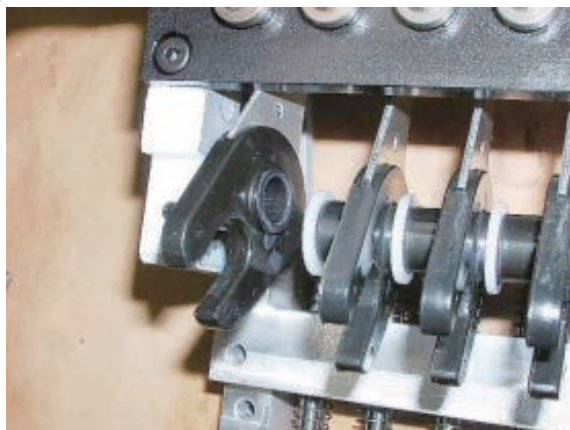

6. Remove plastic washer.



7. Install good take-up lever assembly with plastic thrust washer, plastic washer, E-ring.

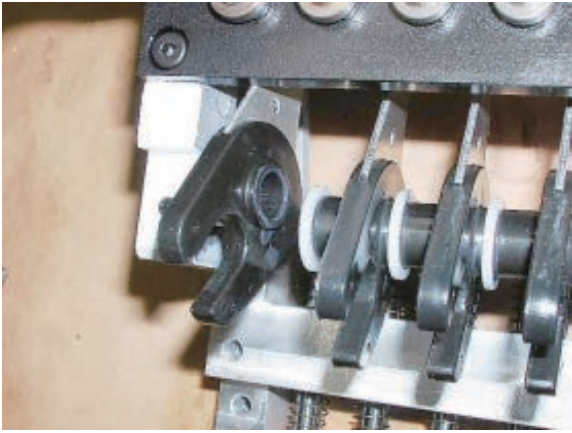

8. Leave space of [0.2mm] between take-up lever and moving head .

Tight screw for "Take up lever shaft"

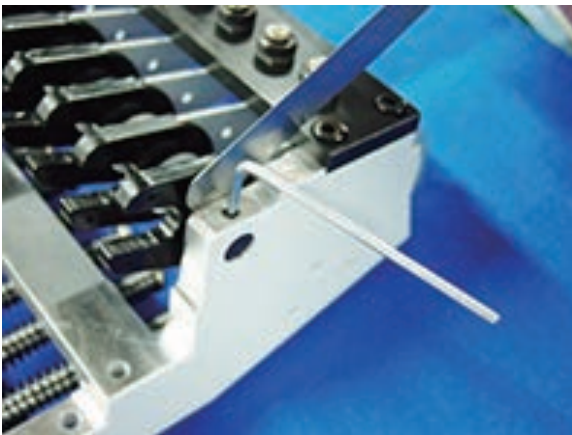

9. Put moving head in previous position to finish.

3-3-10 Adjustment of thread holder

1. Loosen screw to the extent that thread holder moves.

(Fixing screw 4 pcs)



2. Please put out and withdraw thread catcher by your finger and fix holder position at smoothly moving position.

<Caution> Please check smoothly moving at 1st and 12th needle.



Positional relationship between hook and holder (lower)

When downing the needle, should have gap more than 1 mm between catch hook and presser foot.

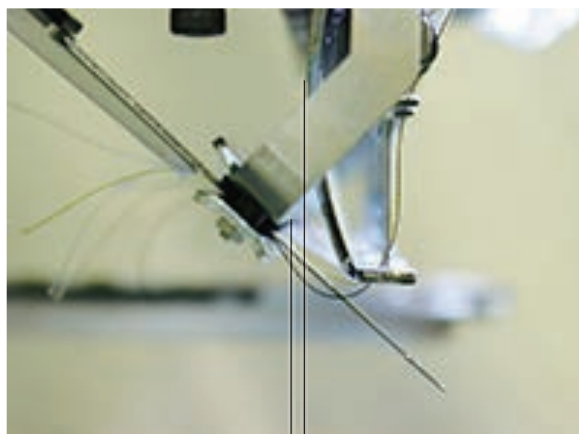

More than 1 mm

4. Thread catcher device should be adjusted if above clearance is not keepable.

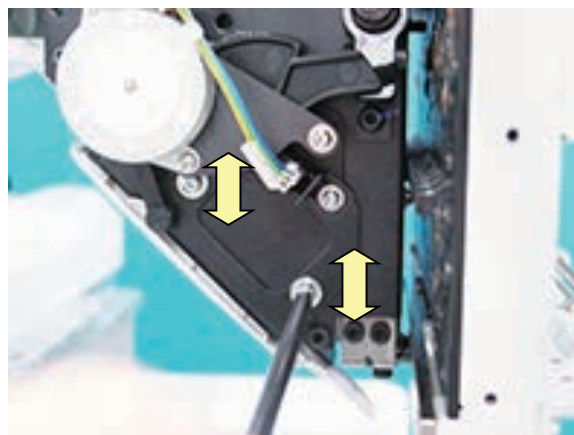

5. Press thread trim key and confirm whole thread trim revolution.

3-3-11 Exchange of majic-tape on thread holder

1. Remove thread holder ass'y. (Fixing screw 4 pcs)



2. Remove holder (lower). (Fixing screw, nut 2 pcs)



3. Exchange the majic-tape.

<Caution> Please check screw hole right and left side.

Also set point line magic-tape and holder bracket.



4. Assemble holder (lower).



5. Install holder ass'y to moving head in reverse order to finish.

Please refer to [3-3-10 Adjustment of thread holder].

3-4-1 Fixing of needle bar change unit

1. Place needle bar change unit assembly.

please set positioning hole on unit assembly to positioning pin.

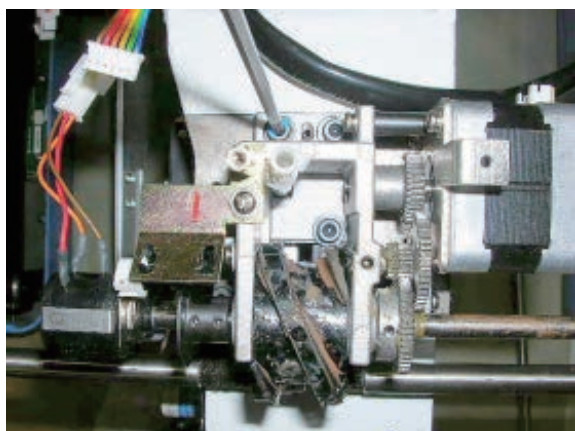

2. Bring needle down, turn upper shaft to set near to [L point].



3. Adjust position of unit assembly so that needle comes to center against needle hole on needle plate and fix screws.



4. Install parts in reverse order to finish.

For adjustment of fixing of each unit, please refer to process to adjust fixing of each unit.

3-4-2 How to take out needle bar change stop position sensor and needle position sensor (potentiometer)

<Note>

Disconnect the plug during the work.

1. Move the head to 15th needle by turning a knob by hand.

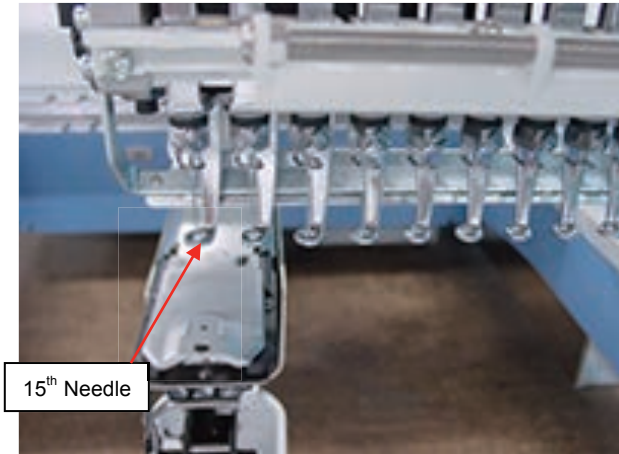

2. Take out cover for needle bar change unit.

Remove the bellow mounting screws (2 places) and take out cover for needle bar change unit.

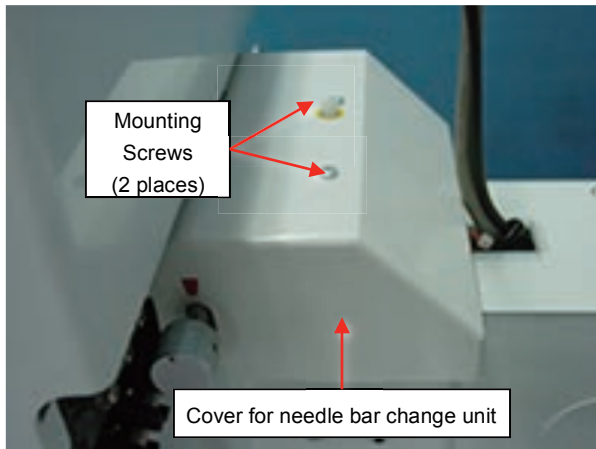

3. Remove connectors for cables of Needle bar selection (2 places) showed as showed bellow.

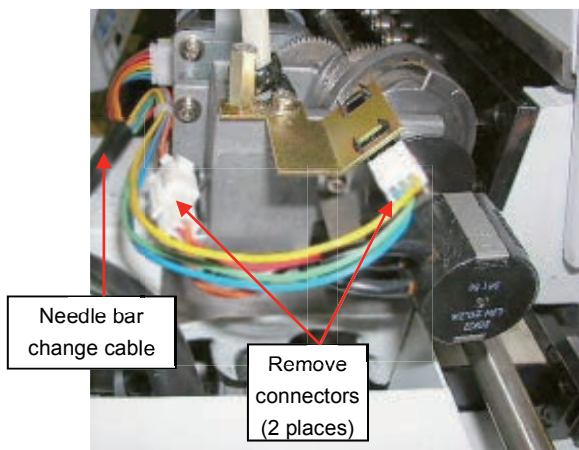

4. Mounting screw and stud a as showed bellow and take out sensor board

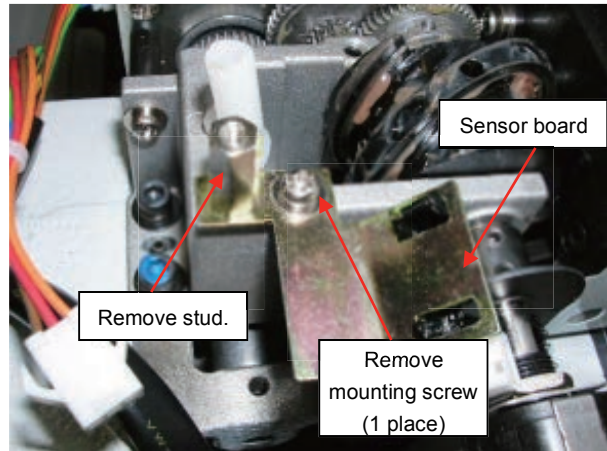

5. Take out potentiometer.

Remove mounting screws (2 places) as showed bellow.

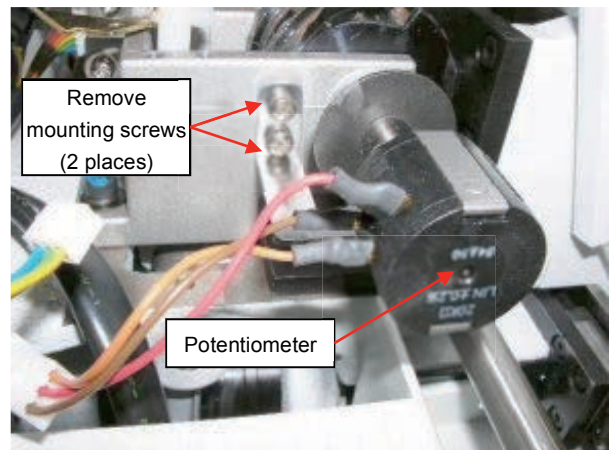

6. Loosen a mounting screw as showed bellow.

Potentiometer can be taken out by pulling to the arrow direction.

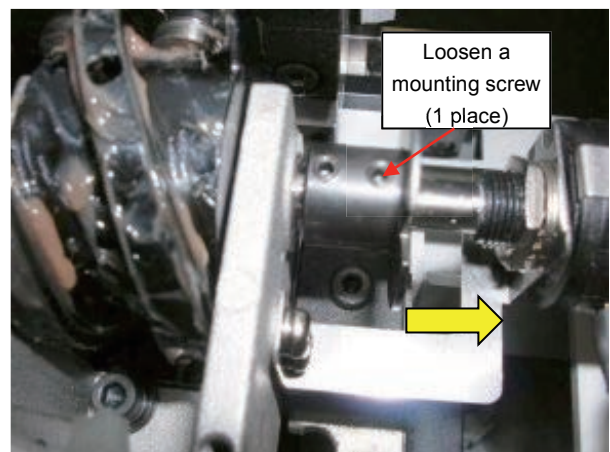

Finish of procedures

3-4-3 Setting to detect needle position

It is necessary to memorize the value of needle selection sensor along the needle positions.

Lateral motion of the machine may not be done normally without the settings.

1. Remove setscrew of slit collar and remove potentiometer.
Do not remove the cable then.

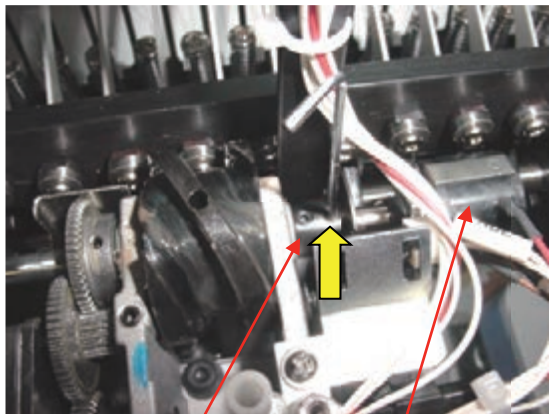

Slit collar Potentionmeter

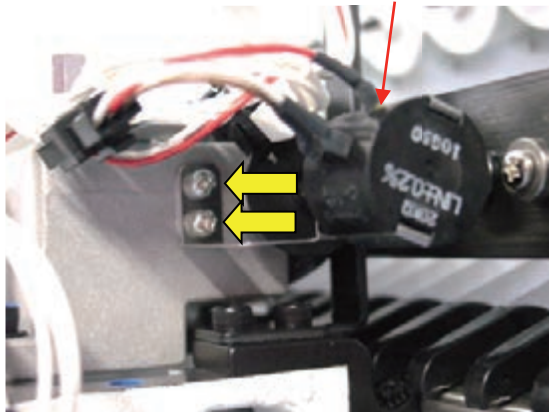

2. Refer to “9-1 How to enter maintenance mode” and enter maintenance mode.

3. Press **Machine Test**.

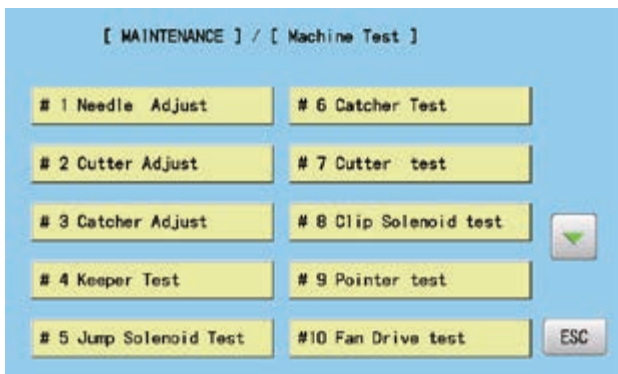

4. Press **Needle Adjust**

Present needle position of potentiometer is indicated.

The number of needle number on the screen is sometimes not the same as the number of actual needle position.

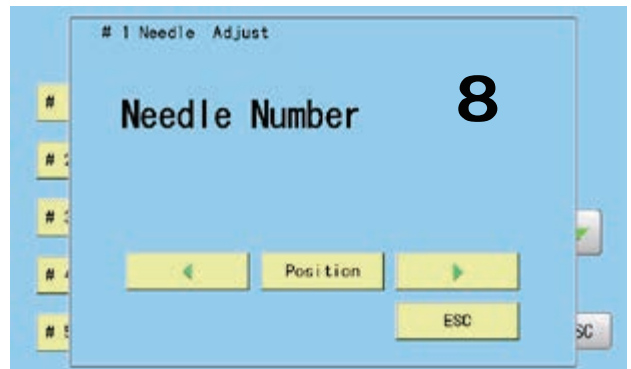

5. Turn knob so that the needle position can be the 6th needle.

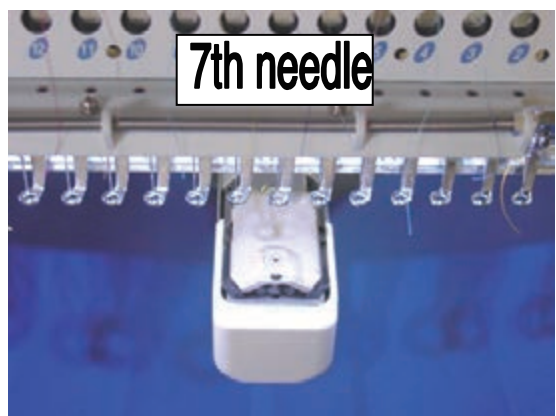

6. Press **Position**.

7. Turn the shaft of potentiometer to reach the 7th needle and continue to turn until *(asterisk) is indicated on the right of the needle number on the screen.

The machine make a beep once * indicates.

The machine dose not make a beep once * disappears.

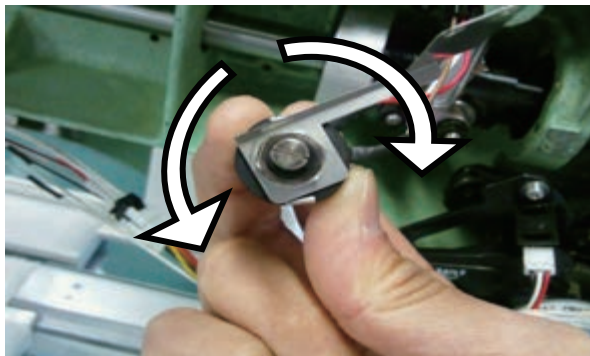
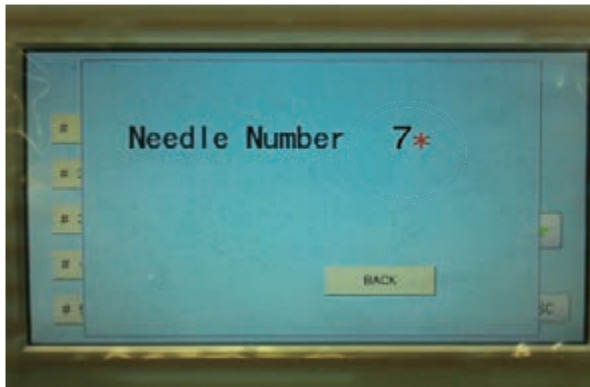

Turning the shaft too much make * disappear, and turn the shaft back and forth, and adjust the position so that continuous beep is made.

8. Install potentiometer at the 7th position while beep is made and fix it with setscrew.

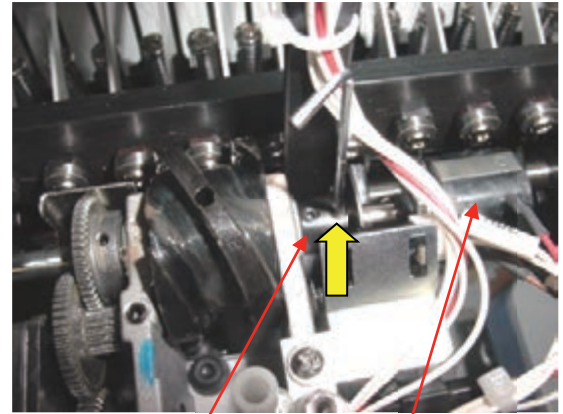

Slit collar Potentionmeter

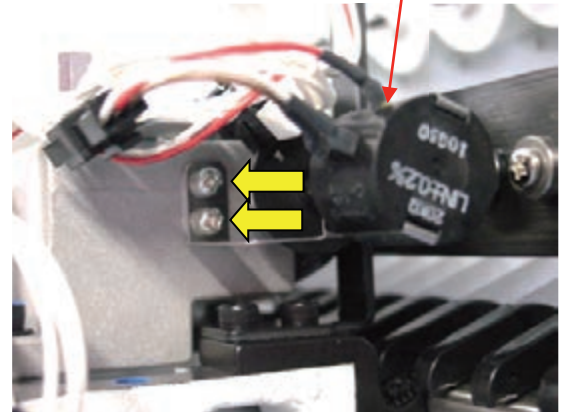

9. Press **BACK** to complete settings.

3-5-1 Exchange and adjustment of rotary hook timing

1. Remove needle plate. (Fixing screw 2 pcs)



2. In case of you would like to replace rotary hook to new one, please remove retainer on bobbin case holder and loose three screws on rotary hook.

Referring to [3-5-2 Adjustment of retainer on rotary hook] adjust retainer on bobbin case holder

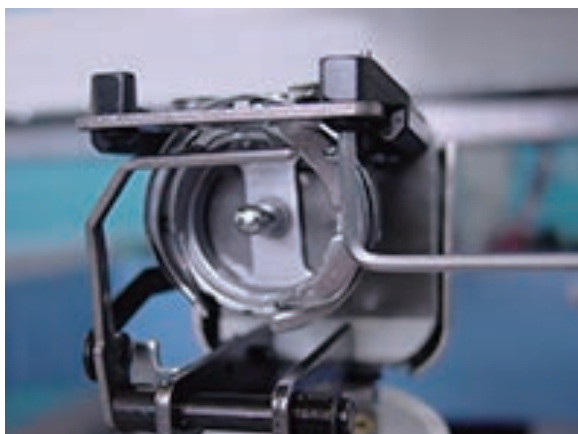

In case of you do not replace rotary hook, do not need remove retainer. Just loose three screws on rotary hook.



3. Bring needle down.



4. Turn upper shaft and set dial disc to [25 degrees].

<Caution> <Note> Please turn shaft and down needle carefulness to needle hit to inner rotary hook.

Dip point of Inner hook for retainer should upper position Like "Picture 5".

"Needle should pass a hole behind of dip of inner hook."



5. Adjust rotary hook timing.

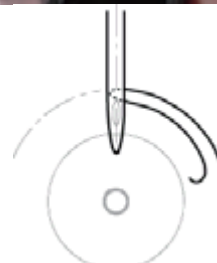

At this moment, clearance between needle and rotary hook should be [0.1 - 0.2mm].

Check and adjust with 1st, 8th and 15th needle.

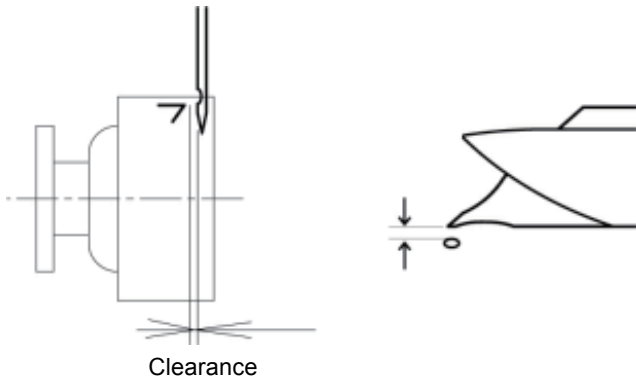

6. For making sure, check position of retainer on bobbin case holder.

Please refer to [3-5-2 Adjustment of retainer on rotary hook] for adjusting value and follow it.



8. Adjustment has finished.

3-5-2 Adjustment of retainer on rotary hook

1. Loosen screw to the extent that retainer on bobbin case holder moves. (2 pcs)



2. Adjust position back and forth, left and right.
Space has to be [0.8mm] and the position right and left is center of the needle.

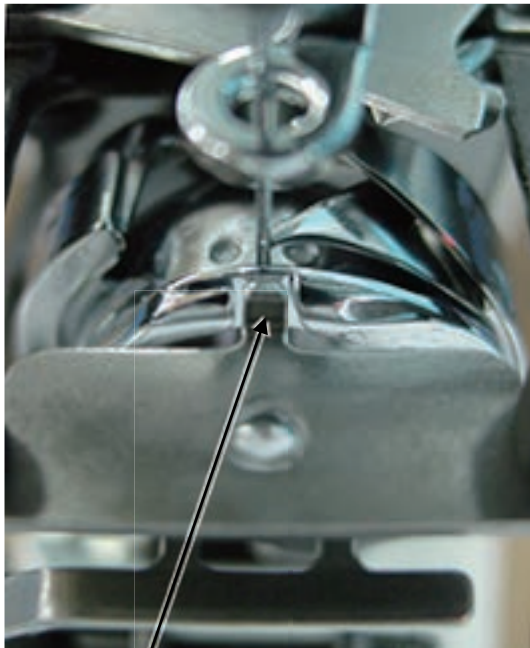

Needle center and retainer center should come to same position.

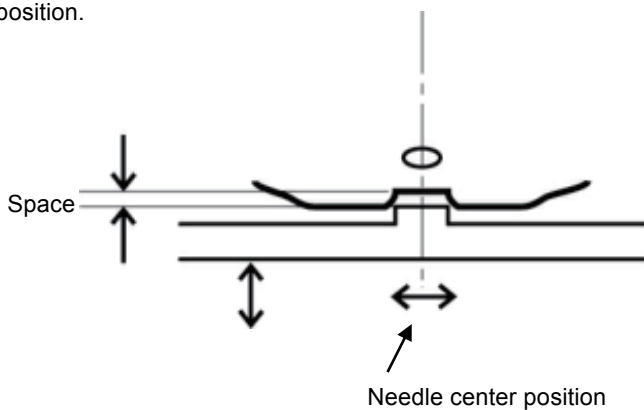

4. Adjustment has finished.

3-6-1 Adjust for Thread trim sensor and stopper

<Note>

Please disconnect power inlet from the wall.

1. Remove needle plate. (Fixing screw 2 pcs)



2. Take off Cover G ass'y

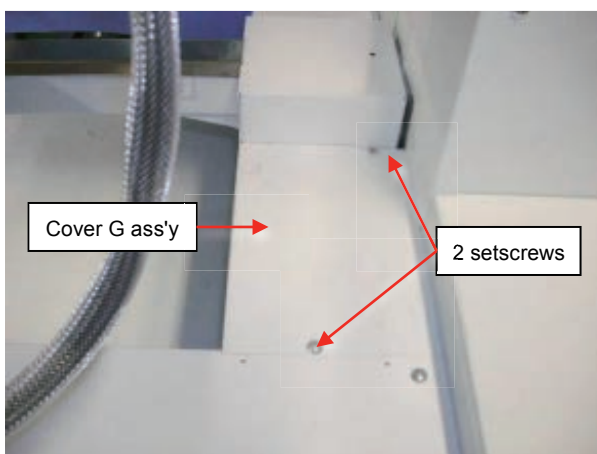
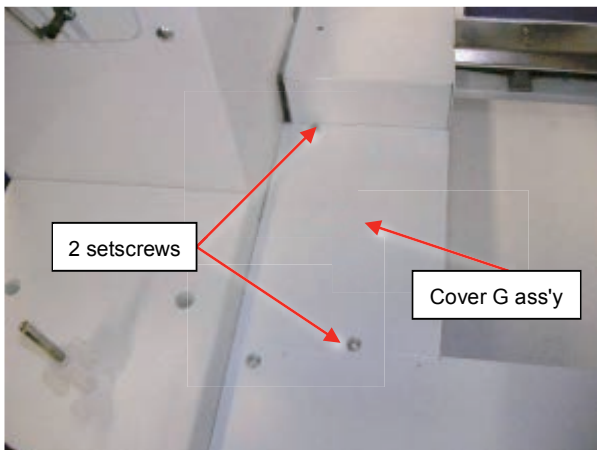

3. Refer to "9-1 How to enter maintenance mode" and enter maintenance mode.

4. Press **[Machine Test]**.

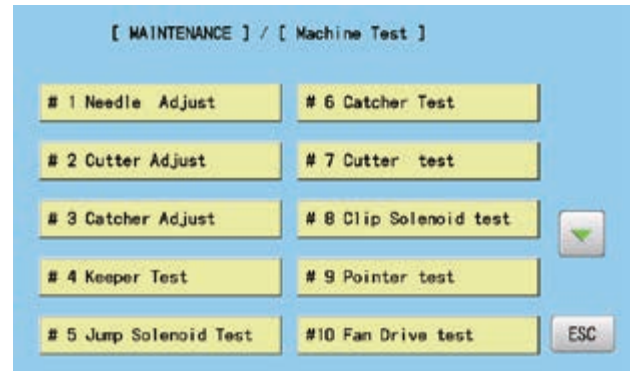

- 5., Press **[# 7 Cutter Test]** and then press **[ESC]**.

Moving knife will move and align with the face of fixed knife. (closing position)

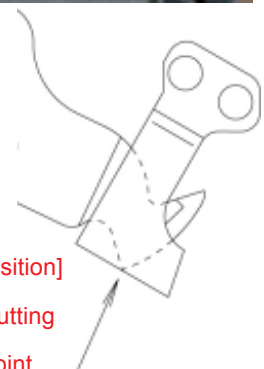
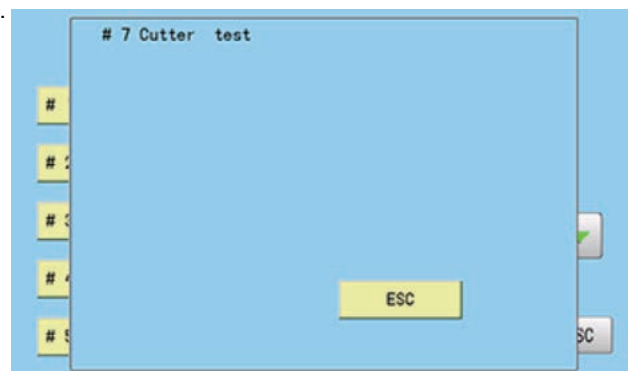

[Detail Moving knife closing position]

Same face "Fixed knife" cutting face and "Moving knife" point.

6. Loose Setscrew for adjusting knife sensor position.

Fix sensor position by sliding knife sensor to [Hide out] or [Come out].

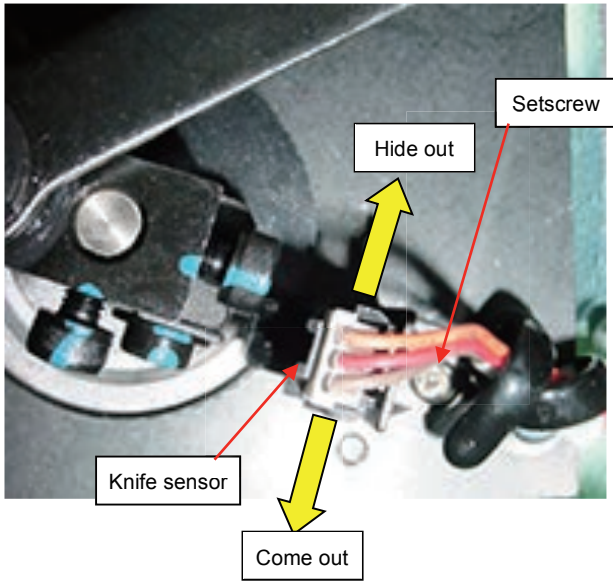

<Note>

Please fix Sensor position to parallel position with Detecting plate

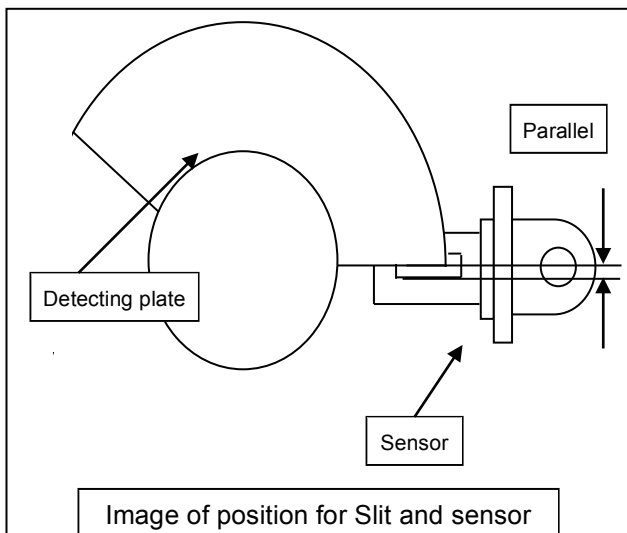

7. Adjust stopper position.

Loose stopper screw and adjust clearance 1mm as following picture.

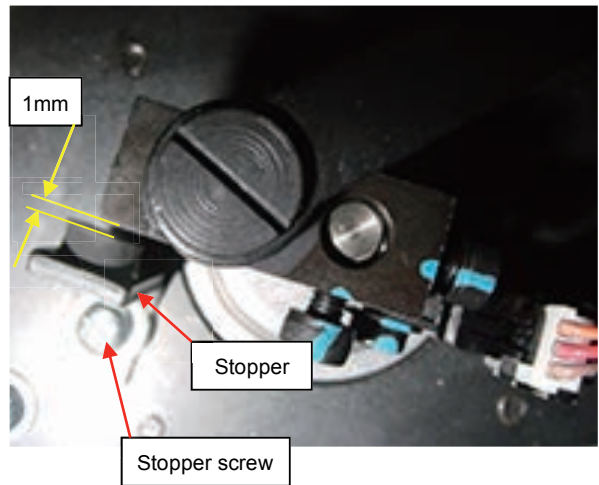

End of process.

3-6-2 Exchange of moving knife

1. Remove needle plate.



2. (1) Refer to "9-1 How to enter maintenance mode" and enter maintenance mode.

(2) Press **Machine Test**.

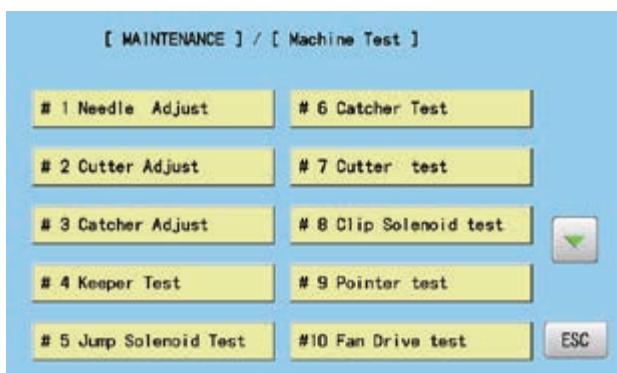

(3) Press **# 7 Cutter Test** and open moving knife.

3. Remove the nut of knife shaft.

<Spanner> 7mm



4. Remove the knife shaft.



5. Exchange moving knife.



6. Fix moving knife with knife shaft and nut.



7. Referring to [3-6-4 Adjustment of moving knife and fixed knife], check how well thread is cut and adjust, then finish this process.

3-6-3 Exchange of fixed knife

1. Remove needle plate.



2. Remove fixed knife.



3. Exchange fixed knife.



4. Tighten fixed knife pushing to forward as full as possible.

Press the fixed knife by off set screw driver.

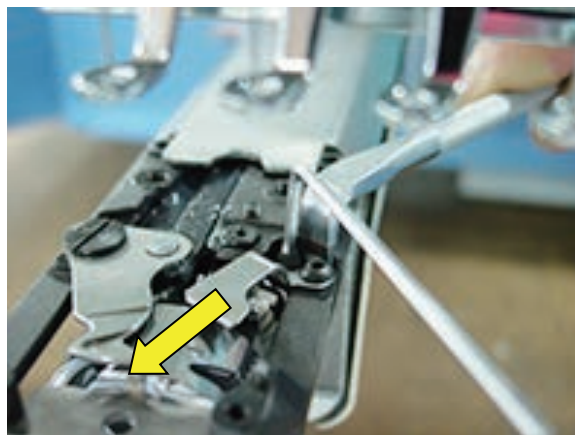

<Caution>

In case moving knife and the left side of fixed knife overlaps excessively when closing, adjust the position of fixed knife slightly to the right direction.

5. Referring to [3-6-4 Adjustment of moving knife and fixed knife], check how well thread is cut and adjust, then finish this process.

3-6-4 Adjustment of moving knife and fixed knife

1. Remove needle plate



2. Adjust slant of fixed knife with [upper adjustment screw] and [lower adjustment screw] that fix fixed knife.

<Note> Rub these screws together to the extent that you don't feel resistance.



<Spanner> 5.5mm



3. Cut thread and check how well it is cut.

Use two polyester threads for checking.



4. Check several times and if no mistakes are found, finish this process.

3-6-5 Adjustment of position of moving knife

1. Remove needle plate. (Fixing screw 2 pcs)

Confirm that the moving knife has closed.



Loosen screw on link pin. (Fixing screw 1 pcs)



2. Open "Moving knife" maximum position by finger.



4. In this condition, Turn link pin till moving knife maximum opened point and fix link pin.



5. At this moment, please check feel "link rod ass'y" little bits play up and down (0.2mm).

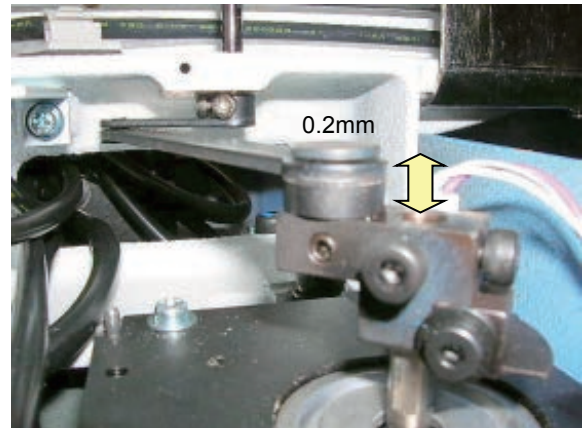

If you had not feel of play, please loose screw on "Drive lever" and slide up or down for make small play of "link rod ass'y"

<Caution> Motor shaft has flat face for setscrew.



Drive lever

3-6-6 Adjustment of bobbin thread holder

1. Remove needle plate. (Fixing screw 2 pcs)



2. Close moving knife like putting bobbin thread between moving knife and bobbin thread holder.



3. Adjust height of bobbin thread holder with adjusting screw.

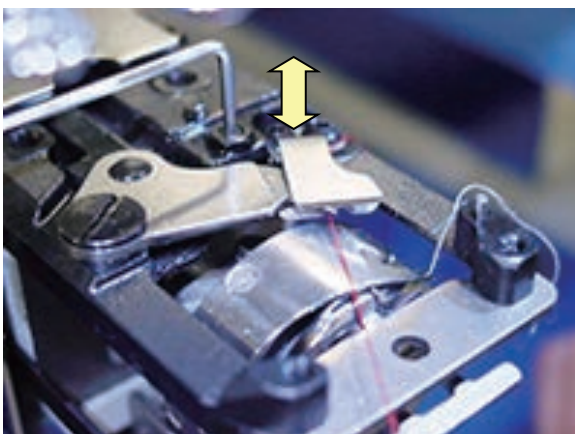

4. Pull bobbin thread toward arrow mark and see that bobbin thread comes off with tensile gauge [20-25g].

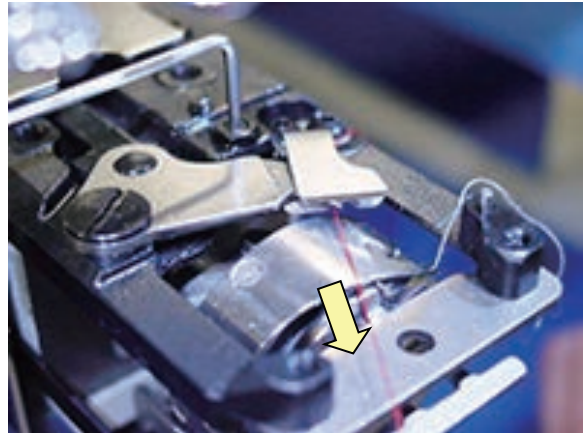

5. Tighten lock nut. (Don't move adjusting screw.)
<Spanner> 5.5mm



6. Check several times and if OK, finish this process.

3-6-7 Exchange of keeper solenoid

1. Remove Bed cover (lower). (Fixing screw 2 pcs)



2. Remove connector for keeper solenoid.

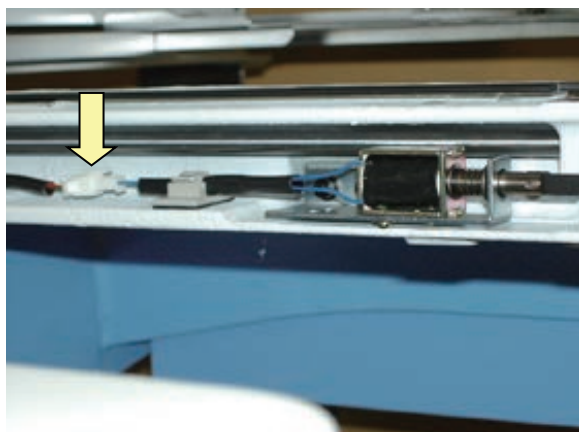

3. Remove E-ring on fulcrum pin.



4. Remove Keeper ass'y. (Fixing screw 2 pcs)

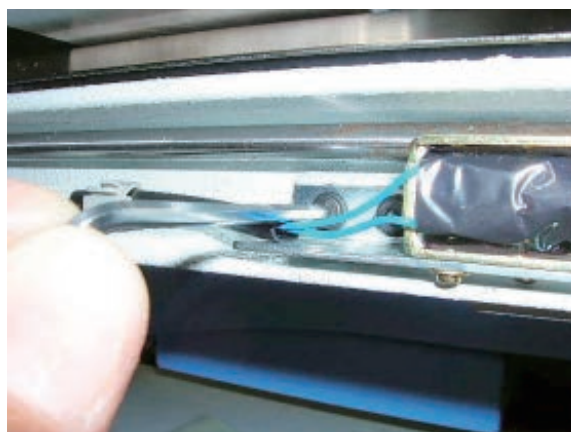

5. Exchange keeper solenoid. (Fixing screw 2 pcs)



6. Install good parts.

<Caution>

Pushing keeper solenoid to solenoid base.

Insert 2.0mm thickness gauge between solenoid base to polyslider.

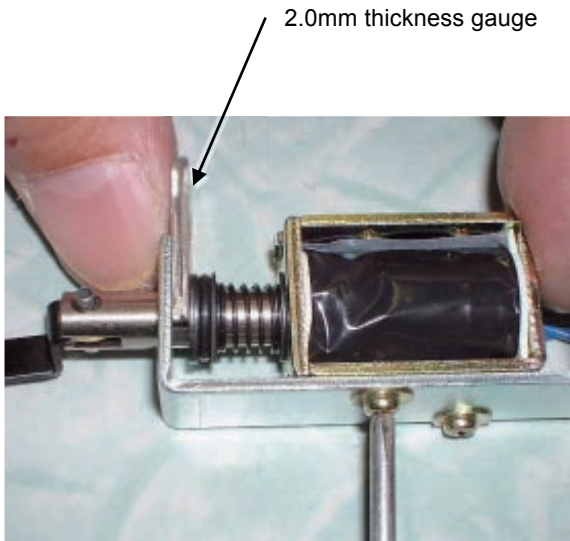

<Front view>

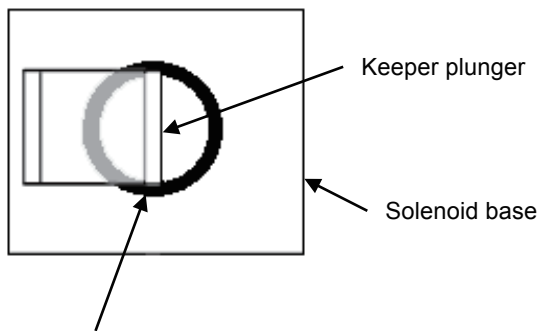

Clearance between keeper plunger and solenoid base should be kept as much as equally.

7. Put keeper solenoid ass'y in previous position then adjustment of position of keeper to finished.
Referring to [3-6-8 Adjustment of position of keeper].

3-6-8 Adjustment of position of keeper

1. Loosen screw on solenoid base. (Fixing screw 2 pcs)

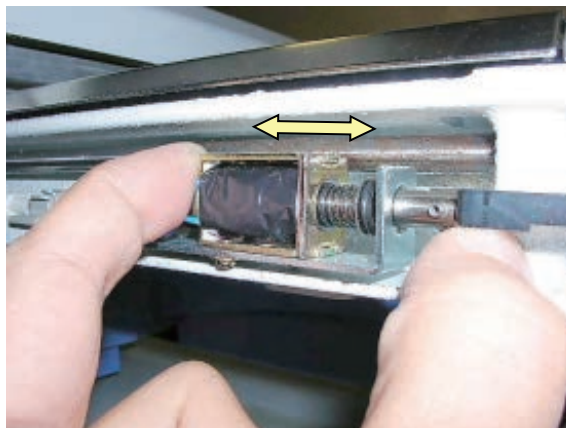
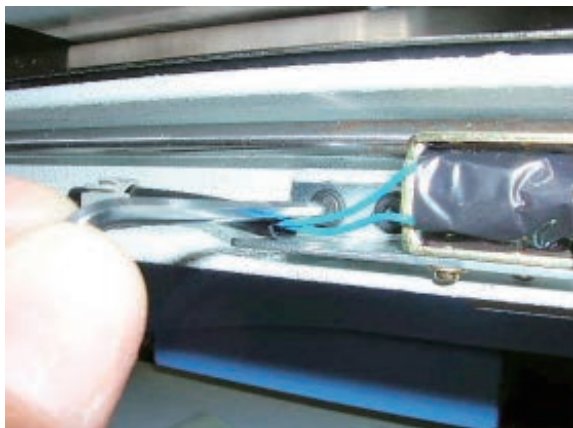

3. Insert keeper positioning gauge (Bobbin) into rotary hook.



<View from right>

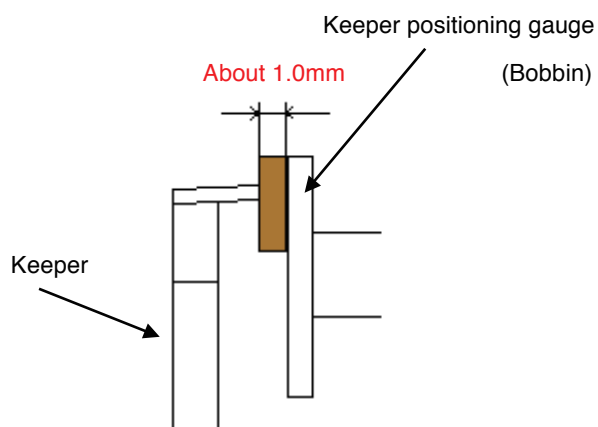

3. Adjust solenoid base where tip of keeper contacts slightly to the gauge then tighten bracket screw. Clearance between bobbin and keeper is [about 1.0mm].



4. Adjust position of stopper.

This is the position where tip of keeper contacts to gauge



5. Adjustment has finished.

3-7-1 Adjustment of X carriage belt tension

1. Remove base cover.

(Fixing screw 6 pcs [12 pcs Wide X-carriage])



3. Loosen fixing screw for tension pulley bracket slightly.

(Fixing screw 2 pcs)

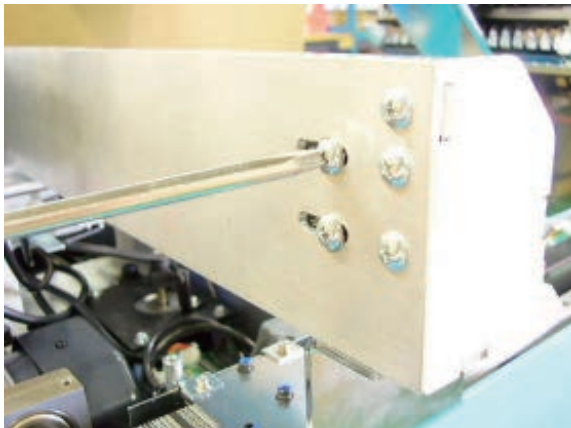

Loosed the adjusting nut.

<Spanner> 7mm



3. Adjust belt tension.

Use push and pull gauge.

Scaling position should center between two position sensor boards. (Please scale it for Wide X-carriage model at center of between first and second position sensor board from right side.)



4. Push the belt by tension gauge at 1.5kg and measure distance between connecting plate and top of the belt. (0.5kg Wide X carriage)

Then adjust the distance to 16mm as picture below.

(17~18mm Wide X-carriage)

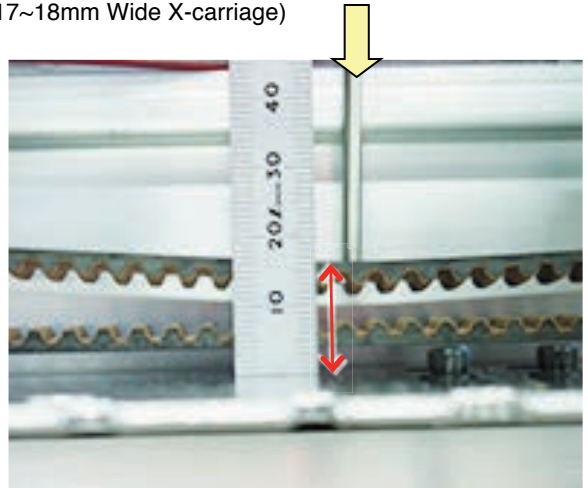

5. Adjustment, tighten fixing screw for tension pulley bracket

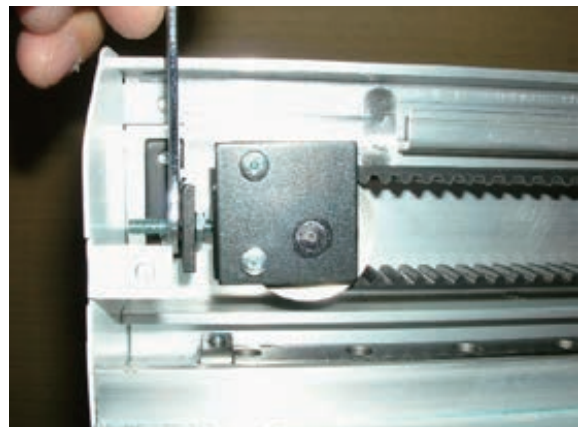

6. Fix tension pulley bracket.

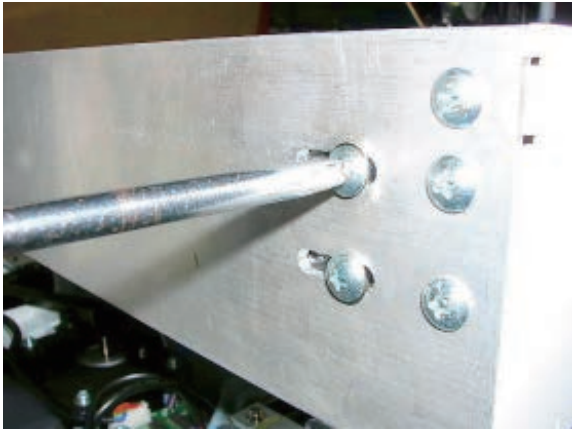

7. Finally check belt tension then tight lock nut.



8. Return things back to previous places in reverse order.

9. Please refer to [9-6 Position—Registration of coordinates for positioning sensor], registry embroidery aria and finish this adjustment.

3-7-2 Exchange of X carriage belt

1. Remove base cover.

(Fixing screw 6 pcs [12 pcs Wide X-carriage])

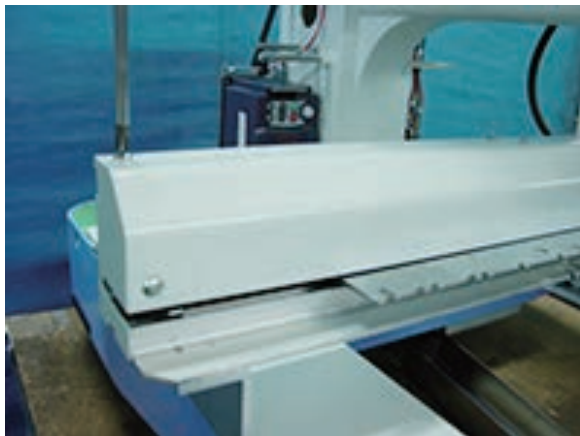

4. Loosed the adjusting nut.

<Spanner> 7mm

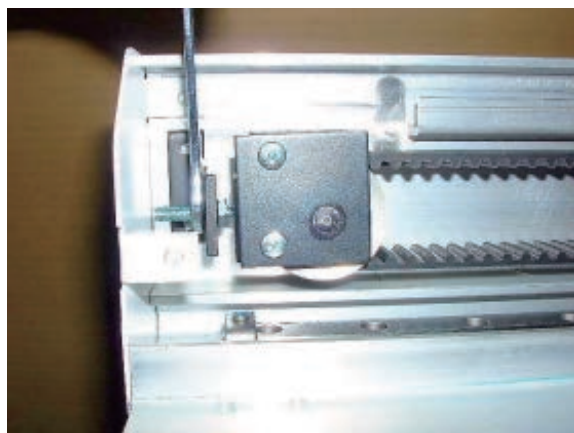

3. Remove detecting plate. (Fixing screw 2 pcs)



5. Remove belt holding plate. (Fixing screw 4 pcs)

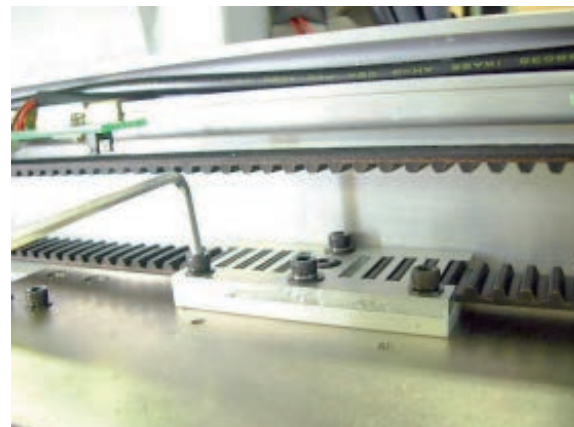

4. Loosen fixing screw for tension pulley bracket slightly.

(Fixing screw 2 pcs)

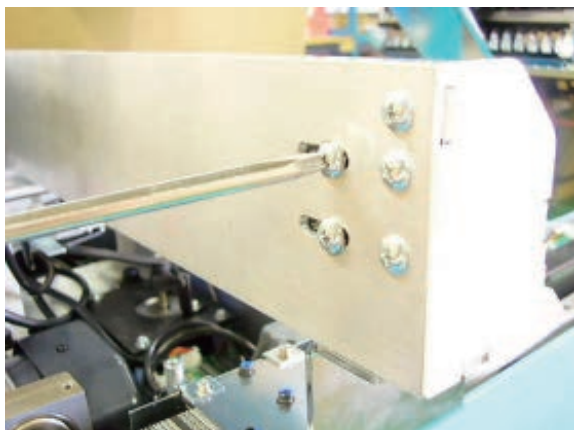

6. Exchange belt to good one.



<Caution> Please do not fit tooth of belt to inside ditch.

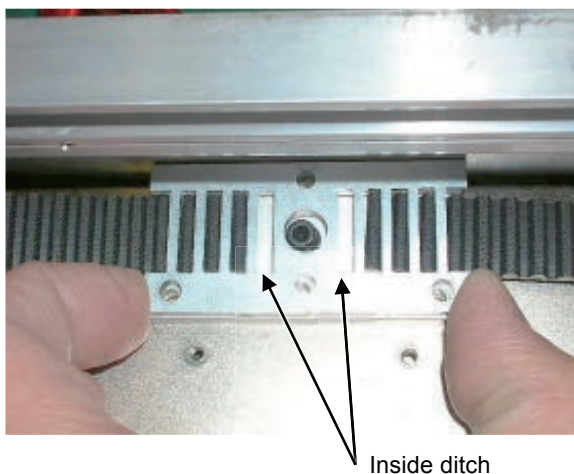

7. Install Belt holding plate.



8. Referring to [3-7-1 Adjustment of X carriage belt tension], adjust tension of belt.

9. Return case cover and frame base to previous places.

<Caution> When set "Detecting plate", please tight screw at insert plate to sensor ditch.



10. Please refer to [9-6 Position—Registration of coordinates for positioning sensor], registry embroidery area and finish this adjustment.

3-7-3 Adjustment of Y carriage belt tension

1. Referring to [2-2 Removal of outer covers], remove cover E and cover F.



Showing from above

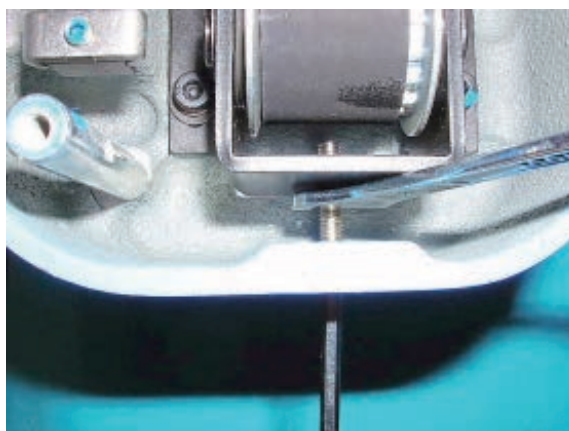

3. Loosen tension screw so as to move tension.



2. Loosen lock nut for tension adjustment screw.

<Spanner> 7mm

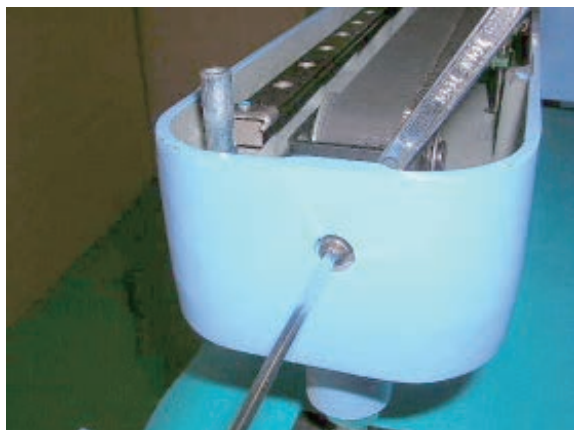

4. Move stay to rear end.

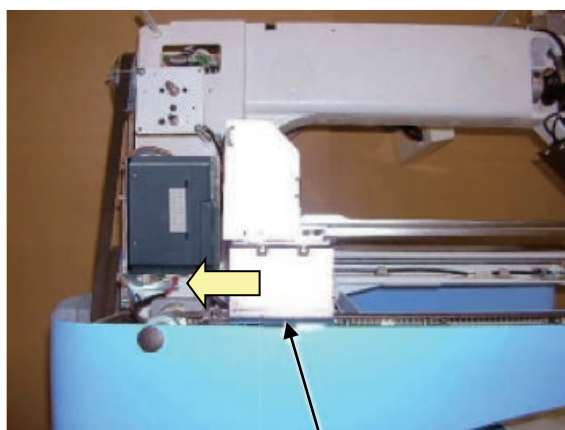

Stay

5. Measure belt tension at between screw hole 9th and 10th.

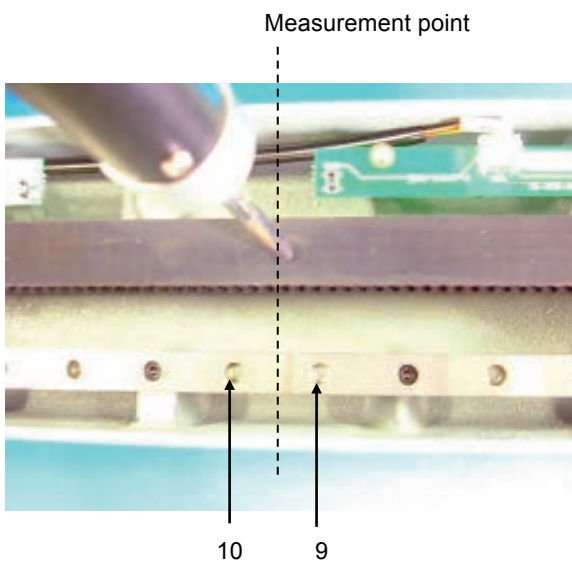
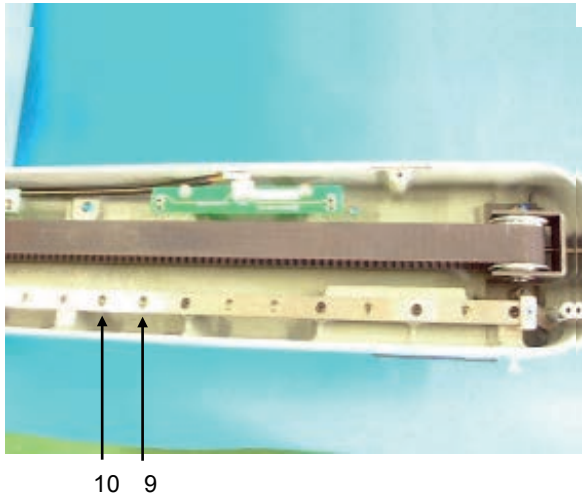

6. Place some straight bar on arm of Y carriage.

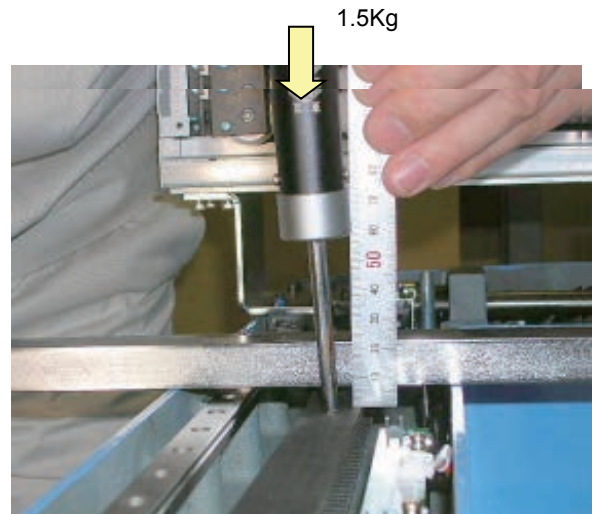

When press belt 1.5kg, should [7mm] apace between straight bar and face of belt.

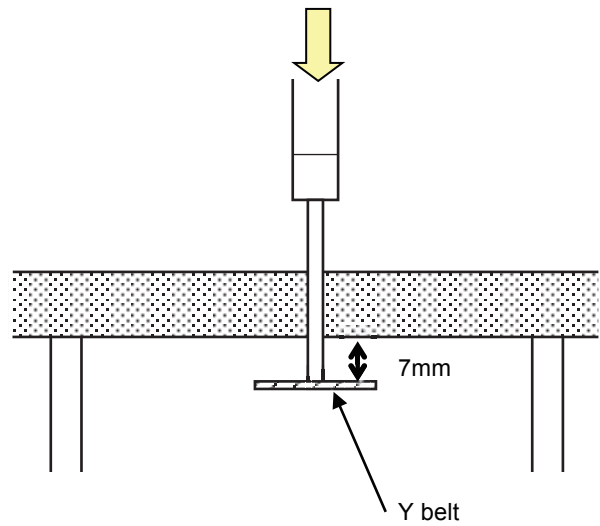

7. Adjust with screw on Idler bracket Y.



8. Fix Idler bracket Y.



9. Check belt tension again then tighten lock nut.



Similarly, adjust Y carriage right also.

10. Put things back in reverse order of respective adjustment.

11. Please refer to [9-6 Position—Registration of coordinates for positioning sensor], registry embroidery aria and finish this adjustment.

3-7-4 Exchange of Y carriage belt

1. Referring to [2-2 Removal of outer covers], remove cover E and cover F.



Showing from top.

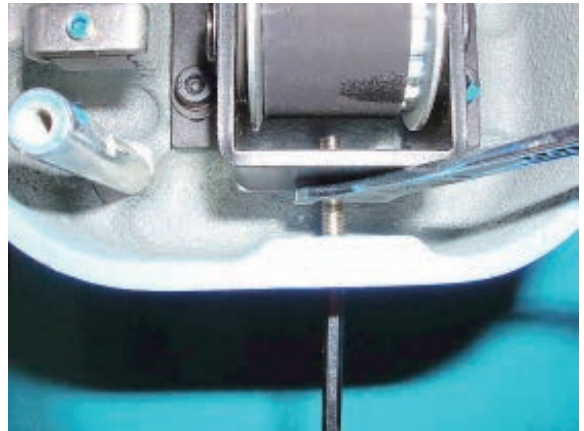

3. Loosen tension screw so as to move tension.



2. Loosen lock nut for tension adjustment screw.
<Spanner> 7mm



4. Remove belt holding plate. (Fixing screw 2 pcs)

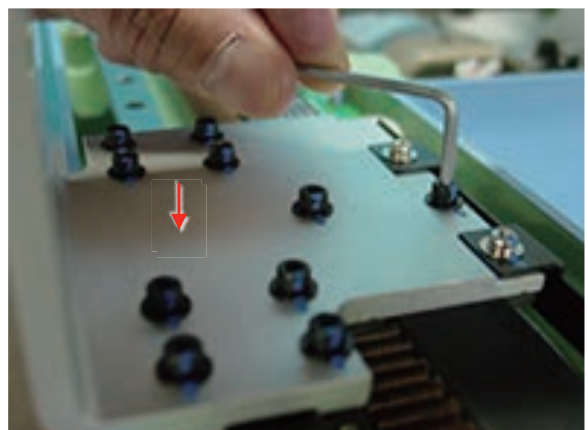

5. Loosen screw on drive pulley. (Fixing screw 2 pcs)



6. Exchange belt.

7. Connect belt at center of belt holding plate.

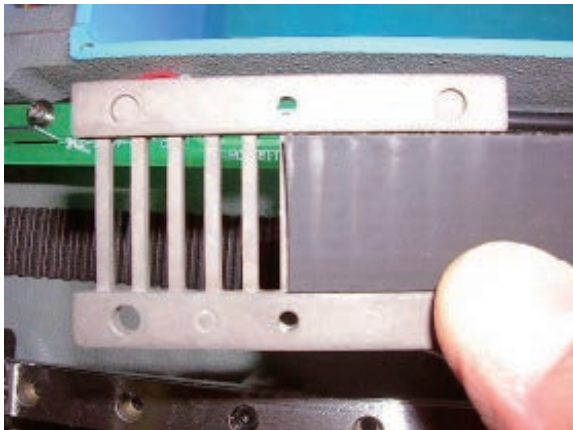

Insert "holding plate" with "belt" to under the "carriage stay" till setting screw hole come from rear side of stay.



Then set rear side belt to "holding plate."

And slide back "holding plate" till setscrew position.



8. Fix belt holding plate.

<Caution> Please care belt dose not out from "belt holding plate".

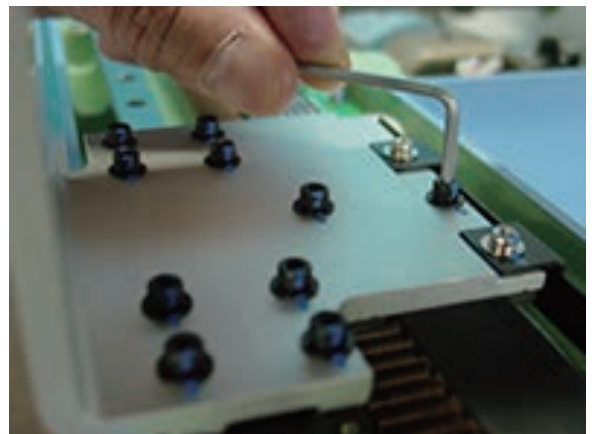
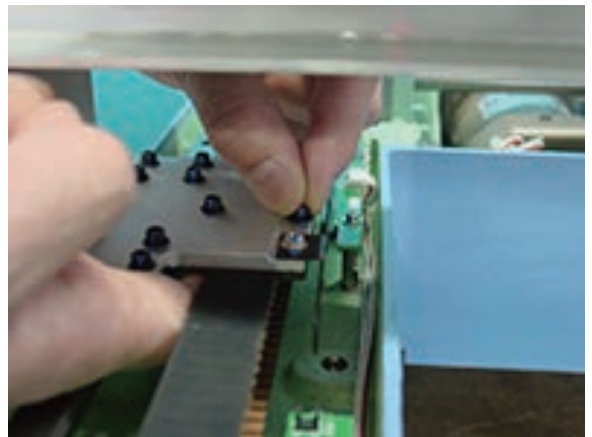

9. Referring to [3-7-3 Adjustment of Y carriage belt tension], adjust tension of Y belt.

10. Loosen fixing screw for X carriage ass'y.

(Fixing screw 4 pcs)



11. Insert positioning pin gauge 6mm.

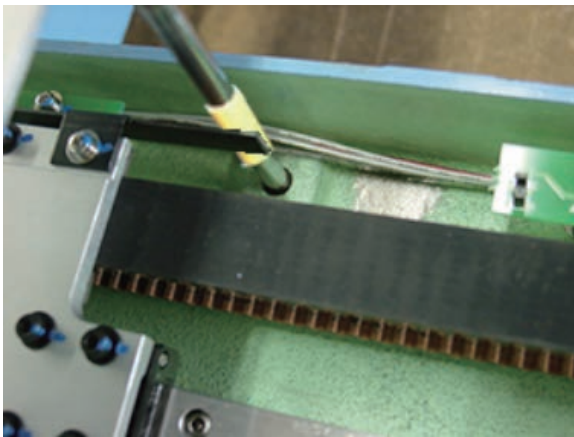

Insert positioning pin gauge to two holes.

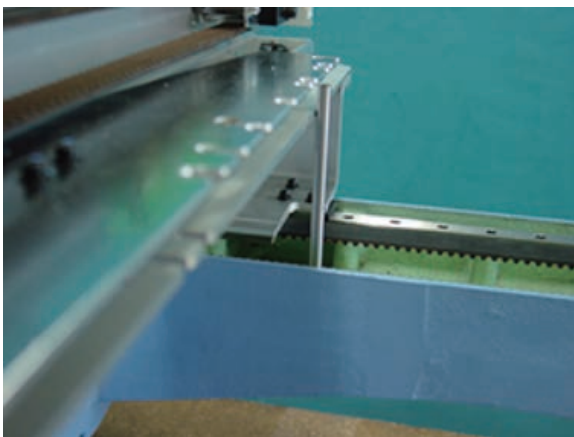

12. Touch X carriage body to pin gauges.

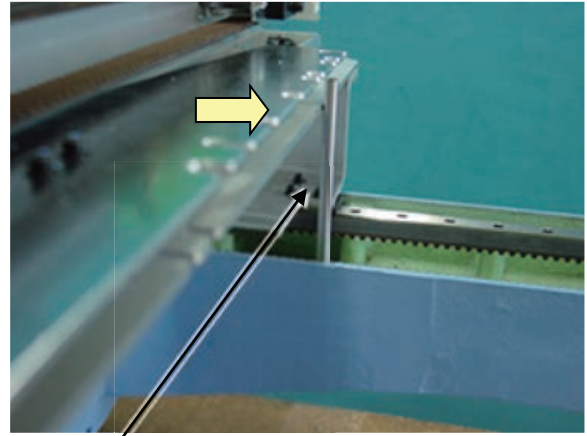

Should not have gap between pin and carriage.

13. Tighten fixing screw for X carriage ass'y.



14. Check no gap between pin and carriage then fix screw of drive pulley.



15. Return cover to previous places.

16. Please refer to [9-6 Position—Registration of coordinates for positioning sensor], registry embroidery area and finish this adjustment.

3-7-5 X carriage limit sensor replacement and adjustment

<Note>

Please turn off machine power.

1. Remove base cover.

(Fixing screw 6 pcs [12 pcs Wide X-carriage])

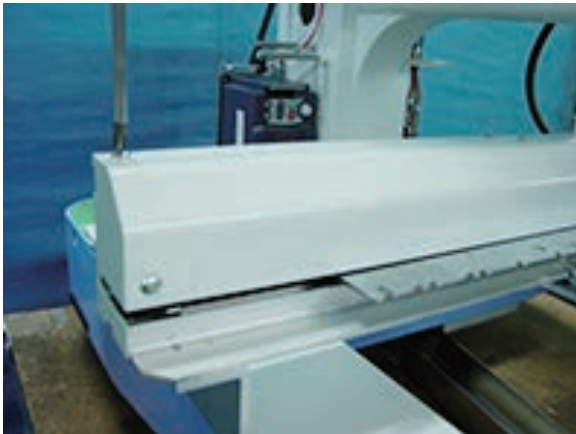

2. Remove 2 setscrews and disconnect the remove sensor board. for sensor cable .

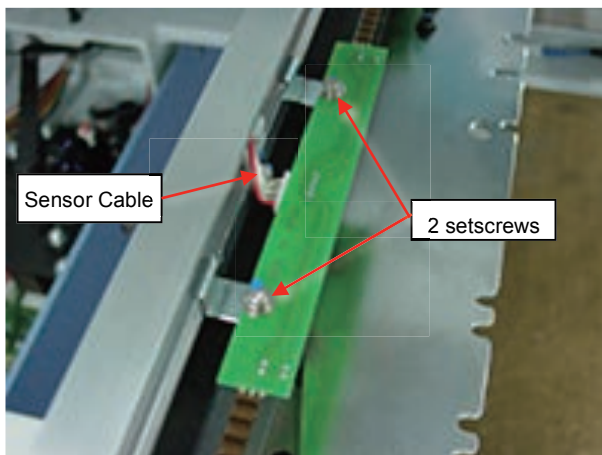

3. Installment of Position sensor board will be opposite procedure from Procedure 2.

<Note>

Detecting plate should be positioned at the center of sensor of Position sensor board.

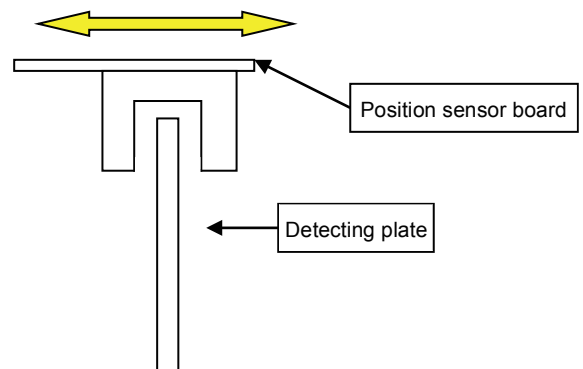
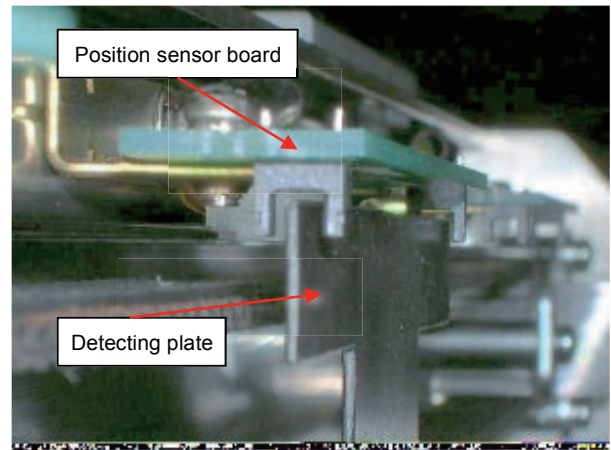

<Note>

[13-6 Coordinate registration for Positioning sensor] should be done at the time of replacement of Positioning sensor.

Adjustment of Position sensor board for X axis is done.

3-7-6 Y carriage limit sensor replacement and adjustment

<Note>

Please turn off machine power.

1. Remove Cover F

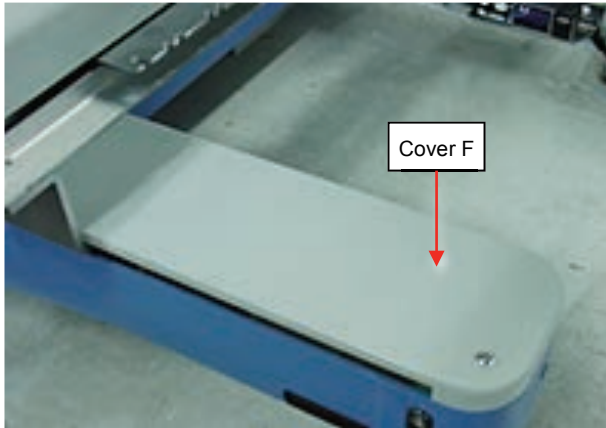

2. Remove 2 setscrews and disconnect the remove sensor board. for sensor cable .

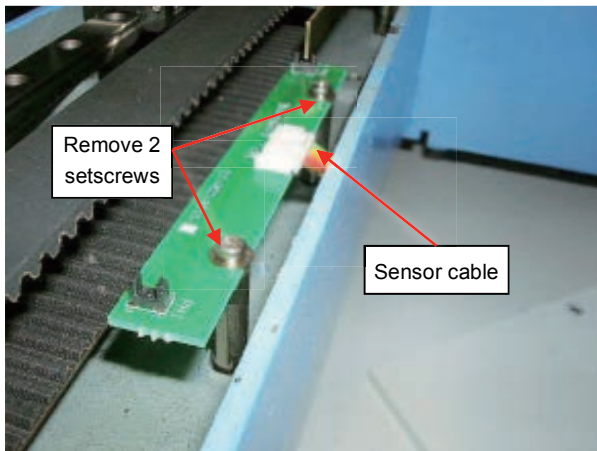

3. Installment of Position sensor board will be opposite procedure from Procedure 2.

<Note>

Detecting plate Y should be positioned at the center of sensor of Position sensor board.

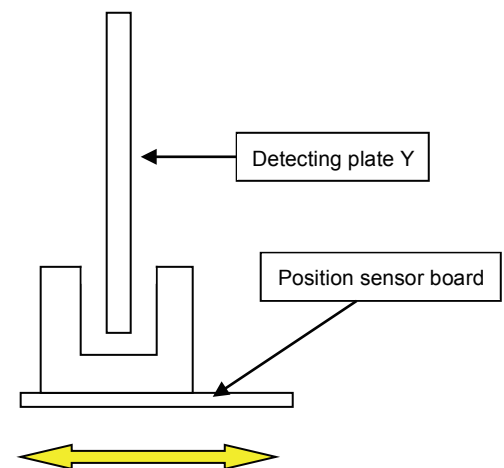
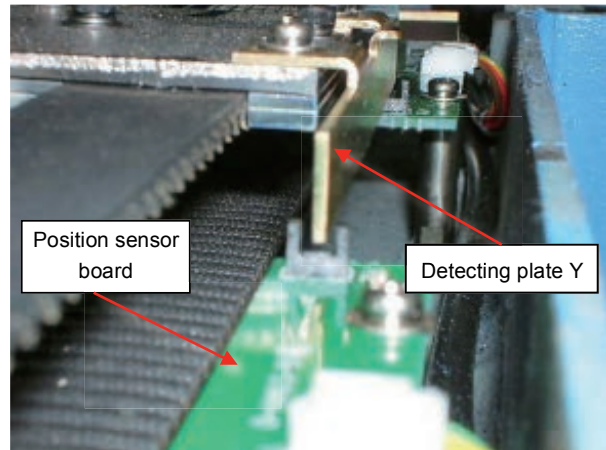

<Note>

[13-6 Coordinate registration for Positioning sensor] should be done at the time of replacement of Positioning sensor.

Adjustment of Position sensor board is done.

3-8-1 Adjustment of timing belt tension

1. Referring to [2-2 Removal of outer covers], remove cover H.



2. Loosen the screw on tension ass'y. (Fixing screw 2 pcs)

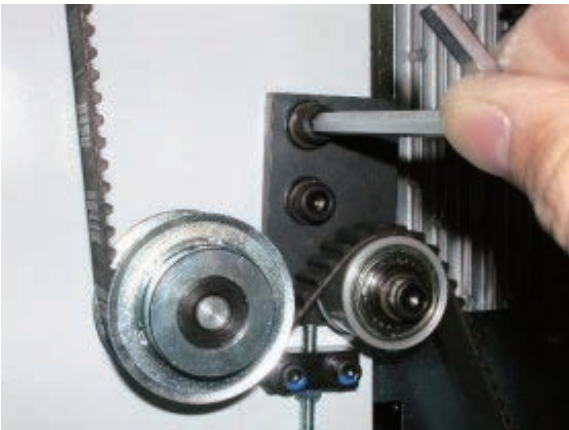

3. Loose fixing nut of tension block about 60 degrees.

<Spanner> 7mm

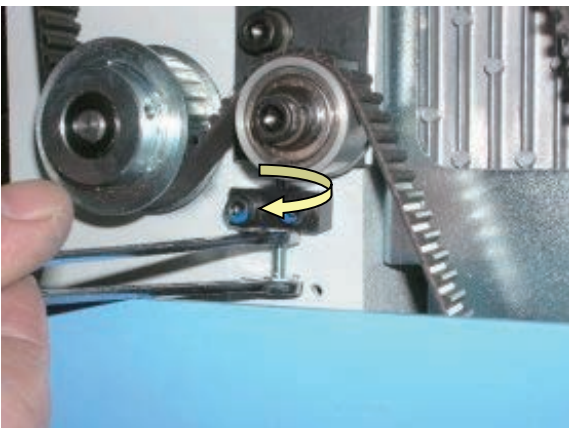

4. Adjust gaps between "Tension ass'y" and "Tension block" to [6.5 to 7.0mm] by adjusting bolt.

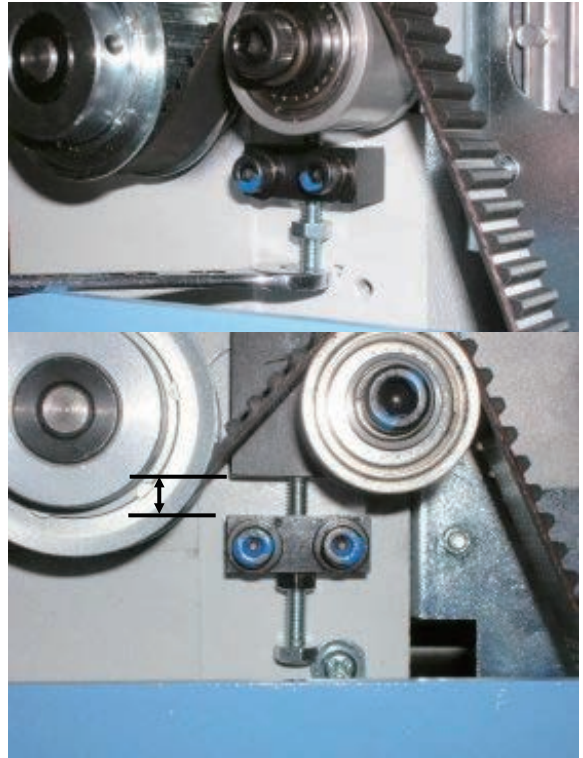

5. Fix tension ass'y (Fixing screw 2 pcs)

Tighten lock nut on tension block.

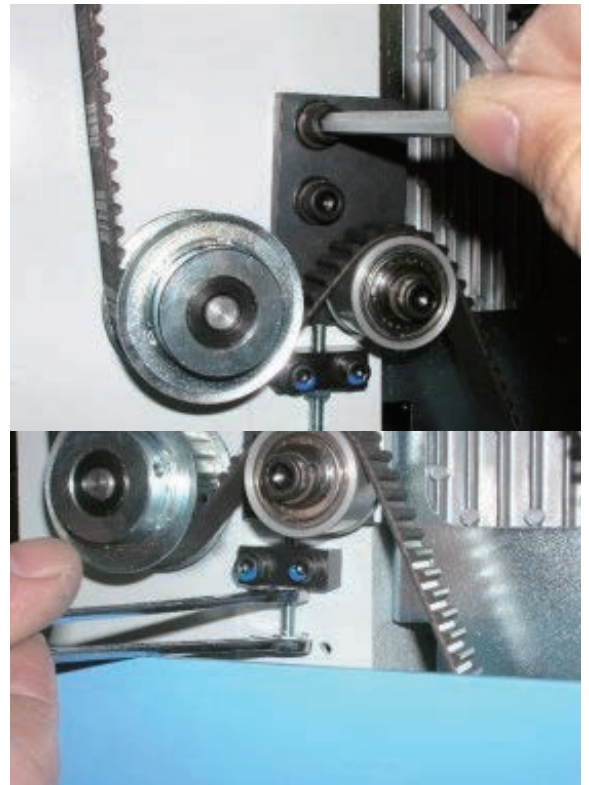

6. Return cover H. to previous places to finish.

3-8-2 Exchange of timing belt

1. Referring to [2-2 Removal of outer covers], remove cover H.



2. Remove pointer. (Fixing screw 1 pcs)



3. Loosen the screw on tension shaft ass'y.

(Fixing screw 2 pcs)

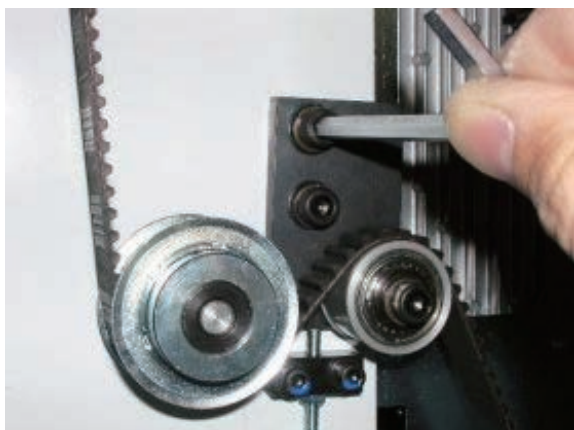

4. Loose fixing nut of tension block about 60 degrees.

<Spanner> 7mm

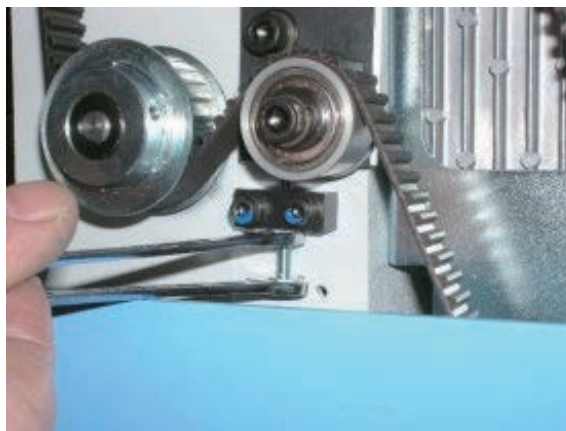

5. Loosed the adjusting bolt.

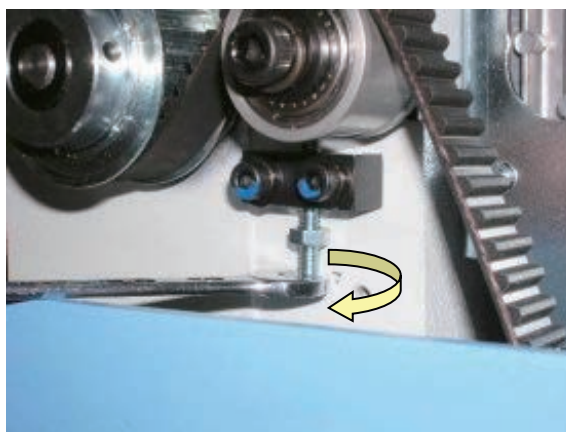

6. Take off the timing belt.



7. Take off the timing belt from motor pulley.

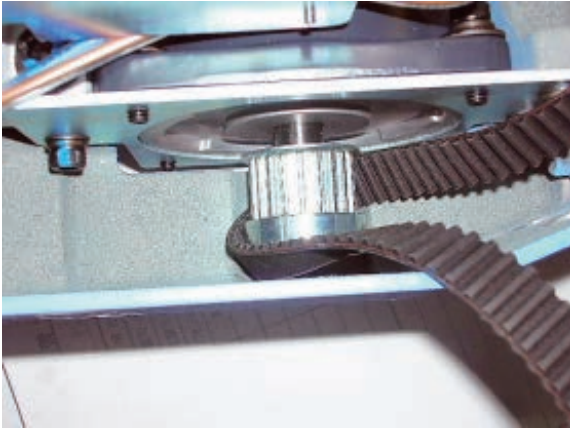

8. Exchange belt to good one.

9. Install each parts in reverse order.

For installation and adjustment of each part,
please refer to respective manuals.

Referring to [3-8-1 Adjustment of timing belt tension],
adjust tensile strength of timing belt.

Check and adjust following timing to finish.

- (1) lowest needle point
- (2) Rotary hook timing.
- (3) Thread cut timing.

3-8-3 Exchange of main shaft timing board

1. Exchange main shaft timing board by the bellow process.
Main shaft timing board consists of detecting slit board and timing slit board as showed bellow.

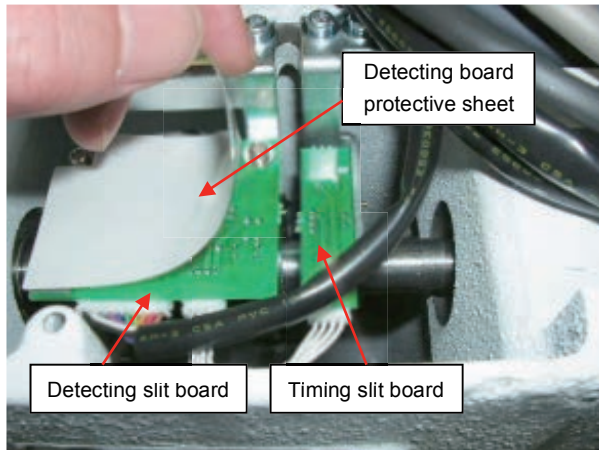

2. Take out detecting slit board.
Remove detecting board protective sheet of Step 1 and remove 2 setscrews as showed bellow. Take out timing cord and encoder relay cord.

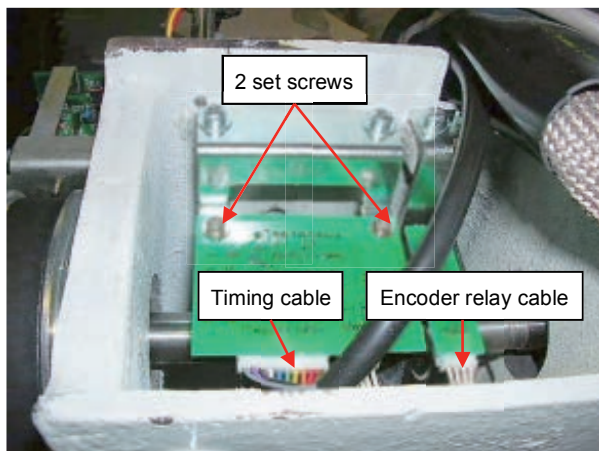

3. Take our timing slit board. Remover 2 set screws and take out encoder relay cord.

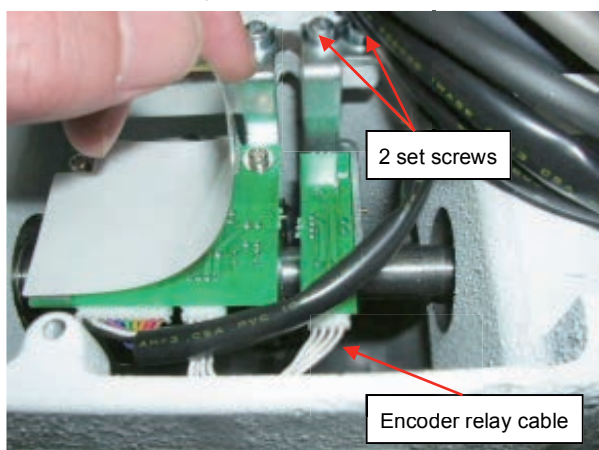

4. Put detecting slit board. Do the opposite procedure of step 2.

<NOTE> Put detecting slit not to touch sensors.

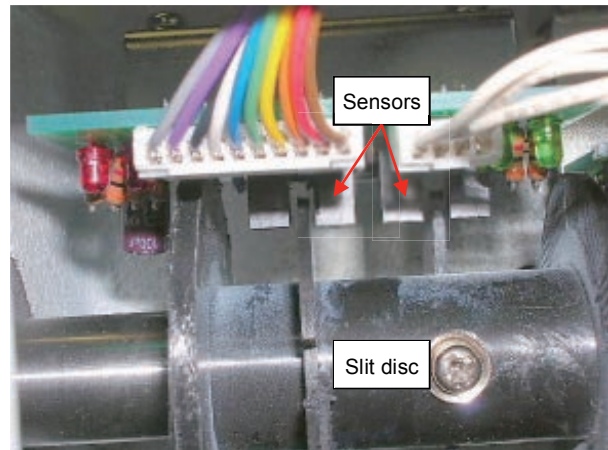

5. Put timing slit board. Do the opposite procedure of step 3.

<NOTE>Put timing slit not to touch sensors.

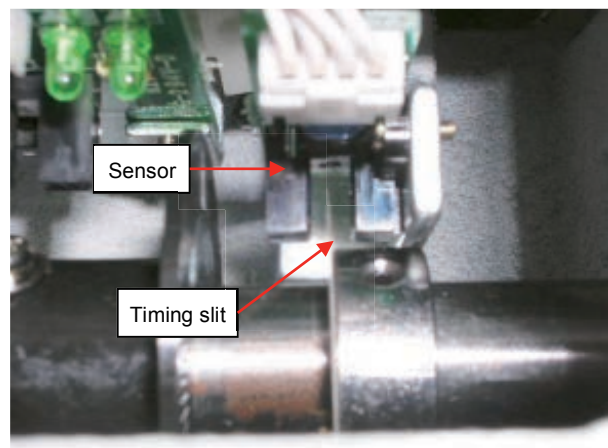

Finish of procedures.

3-8-4 Adjustment of detecting slit and timing slit

1. Loosen the setscrew fixing detecting slit showed as bellow so that detecting slit can turn itself.

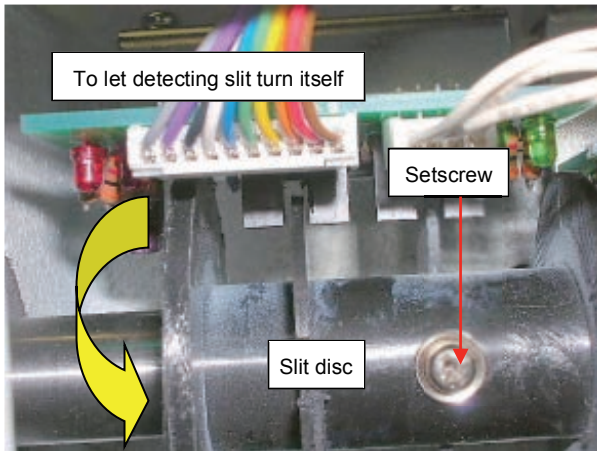

2. Set upper shaft to [0 degree]

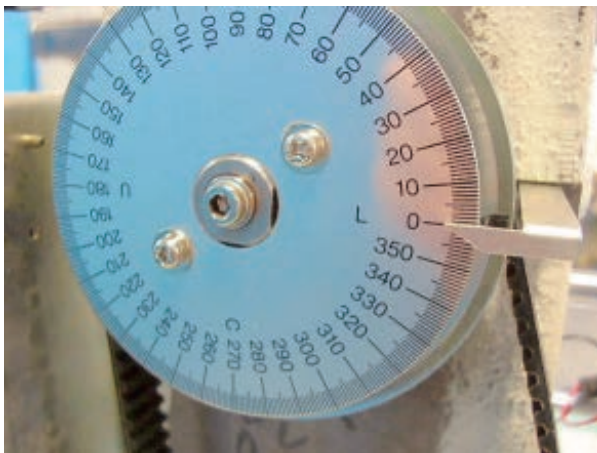

3. Turn detecting slit clockwise from pointer scale to set the position where LED4 goes out and tighten setscrews. (When detecting slit cover in L point sensor, LED4 goes out.)

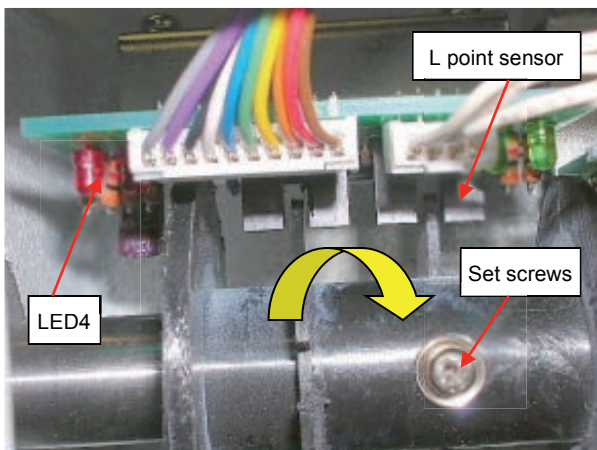

4. After main shaft timing board is set, turn the main shaft and confirm that LED4 goes out at 0 degree (L point).

5. Check C-point.

Turn main shaft by hand and confirm turn-on the LED-3 between 270 degree to 284 degree.

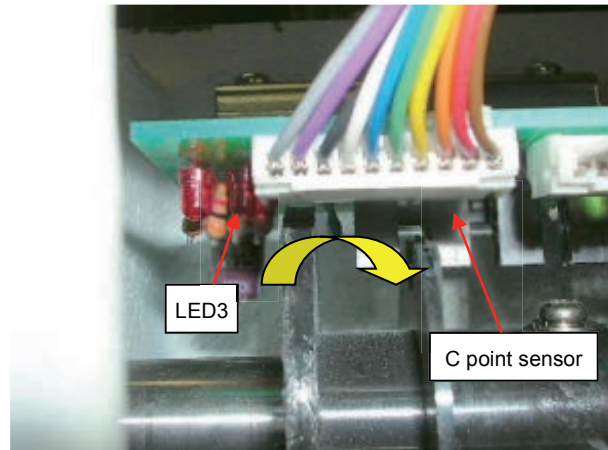

6. <Check>

should not touch sensor and timing slit for L and C.

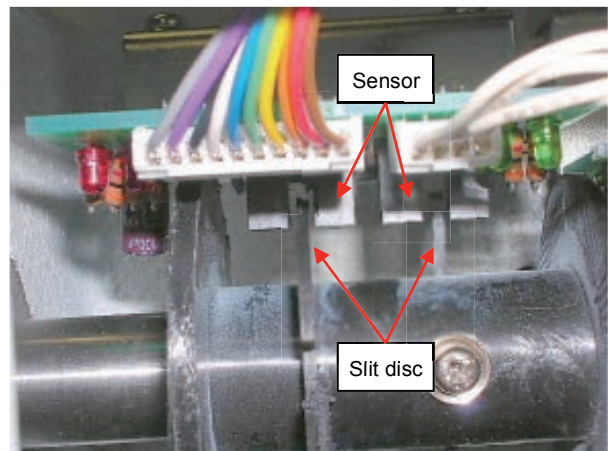

7. Loosen the setscrew fixing timing slit showed as bellow so that timing slit can turn itself.

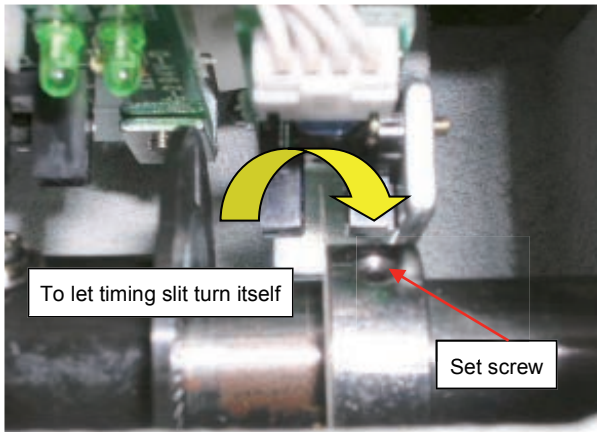

8. Adjust the distance between timing slit and timing board.
As showed bellow, adjust the distance between timing slit and timing board to $[0.7 + / - 0.2\text{mm}]$ and tighten the screw.

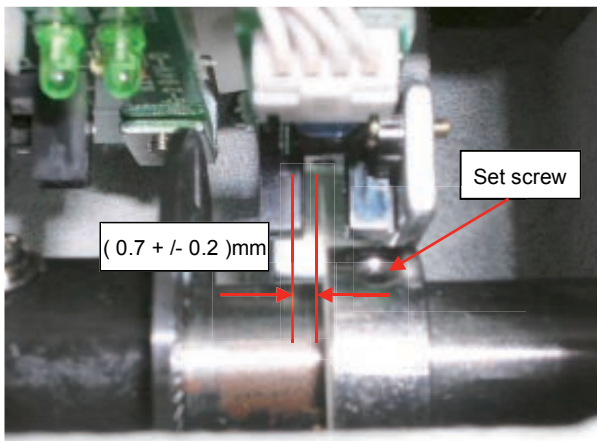

<NOTE>

Be careful not to bend timing slit, because it is very thin.

Finish of procedures.

4-1 Exchange of fuse

<Check>

Make sure that power switch is off before this work.

<Note>

Disconnect the plug during the work.

1. Open a fuse holder cap by pushing and turning counterclockwise with a flathead screwdriver.

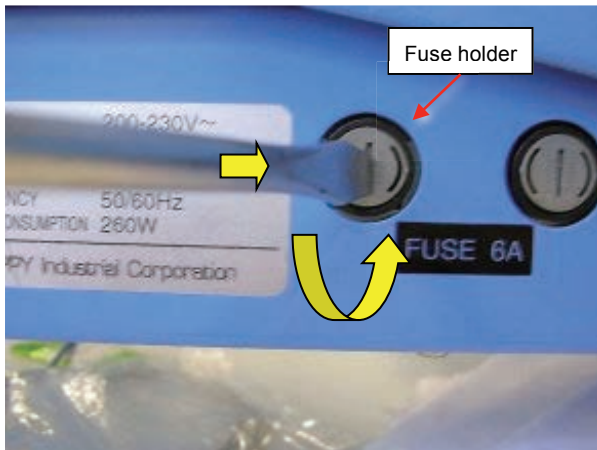

2. After the fuse holder cap and fuse is pushed out, draw them out.



3. Remove fuse from fuse cap holder.

4. Exchange it to the auxiliary fuse.

<Note>

Do not use the other fuse than the auxiliary fuse(3SB6A)

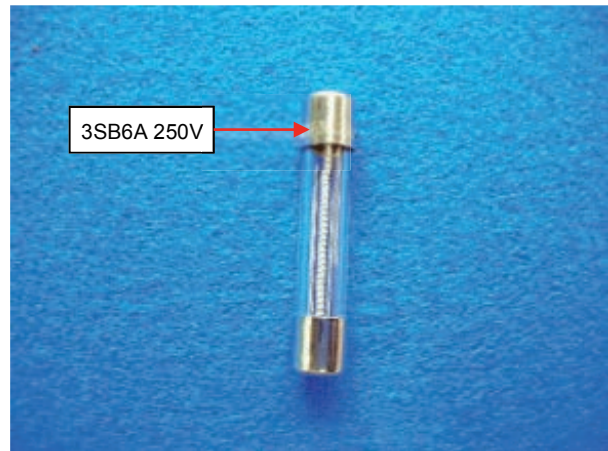

5. Set fuse in fuse holder cap.

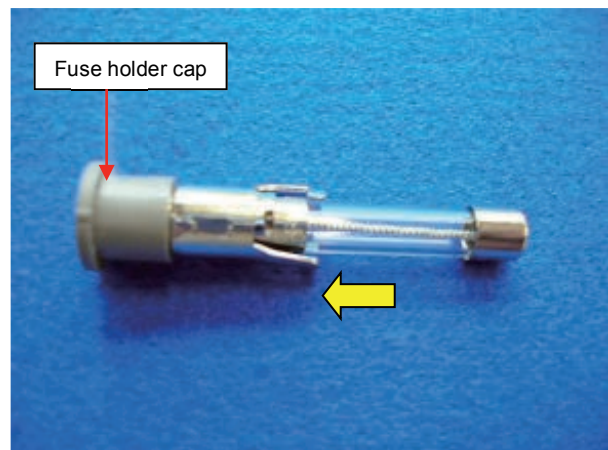

6. Set them in fuse holder and close the cover by turning clockwise with a flathead screwdriver.

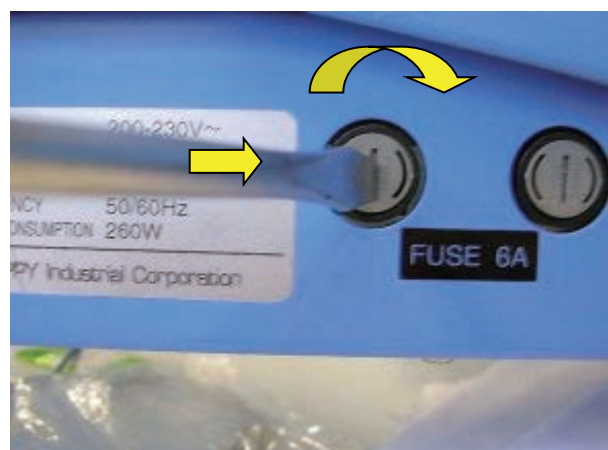

* End of process.

4-2 Exchange of CONT-D2 board

<Note>

Disconnect the plug during the work.

* Remove outer cover (right), referring to [2-2 How to remove outer cover]

1. Take all connectors out and exchange CONT-D2 board.

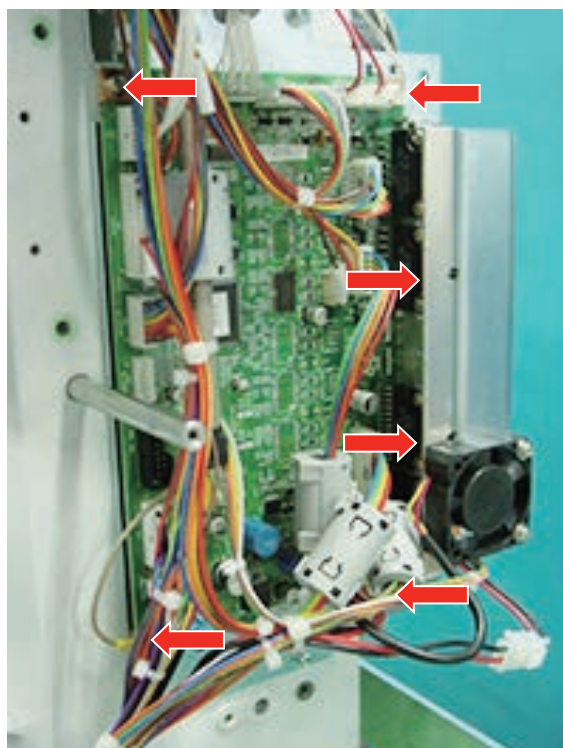

2. Fix screws and connect all cable which are taken.

Proceed machine speed setting.

4-3-1 Exchange of switching power supply

1. Remove Drive A Circuit Board Unit, referring to [4-3 How to remove Drive A Circuit Board Unit]

2. Remove Cover G ass'y by unscrewing total 4 screws at positions as below.

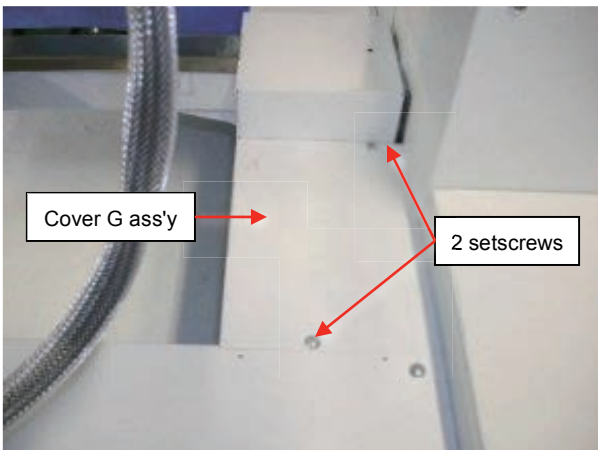
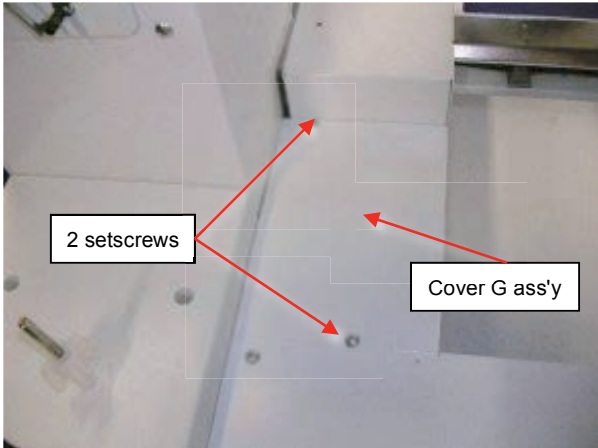

3. Remove Power Supply cover B.

Remove the mounting screw as showed bellow.

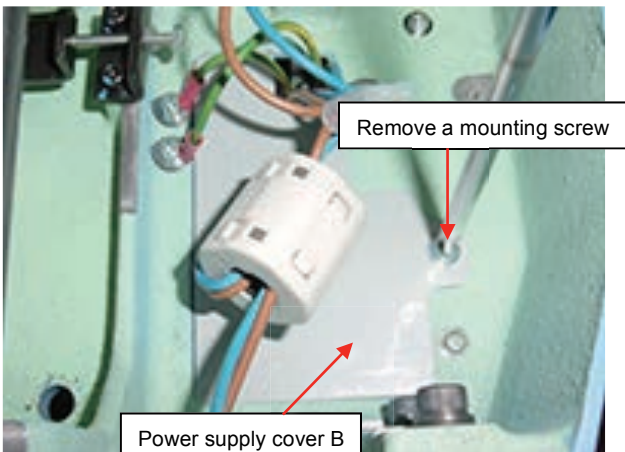

4. Remove the switching power supply cable. (2 places)

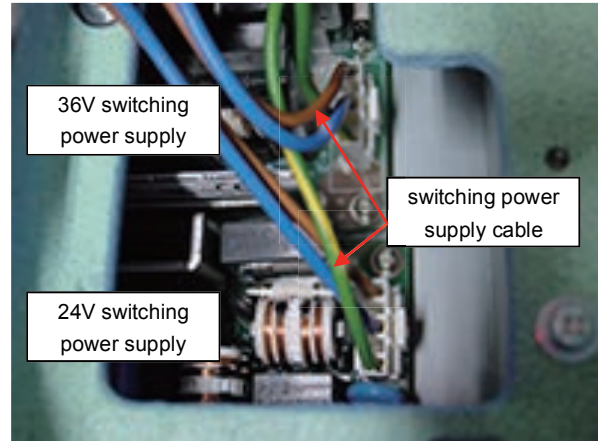

5. Remove Power Supply Cover A.

Unscrew the mounting screw as showed bellow.

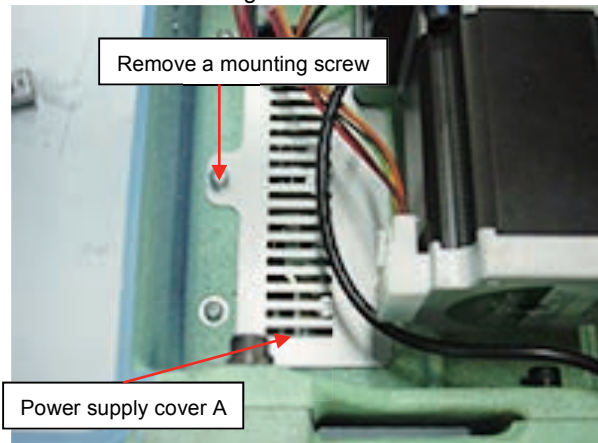

6. Remove DC Power Supply cables (2) from Switching Power Supply (2).

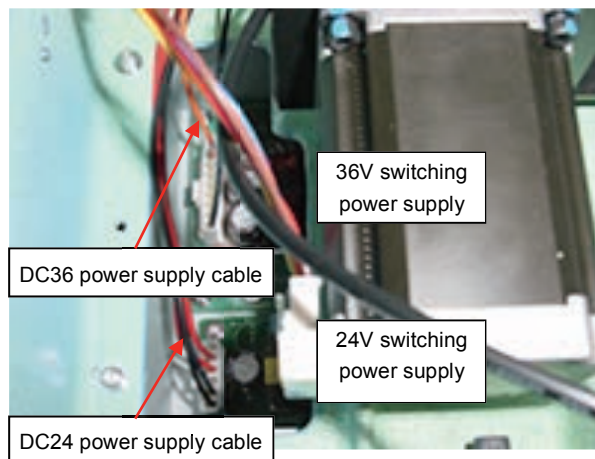

7. Remove Power switch assy box

Remove 4 screws as shown bellow.

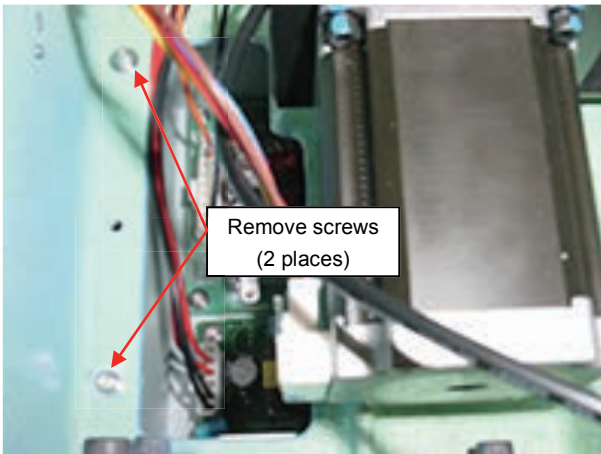
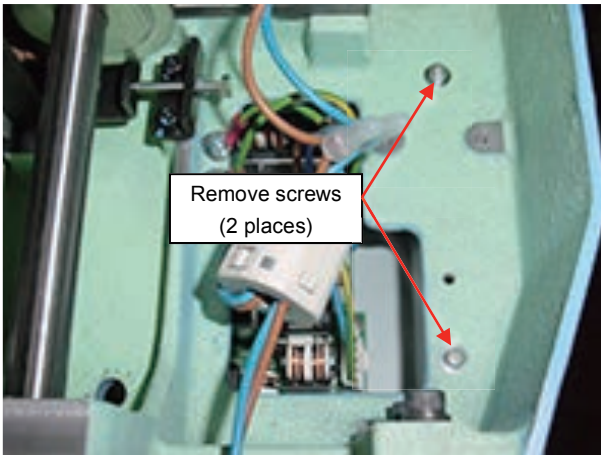

8. Exchange switching power supply

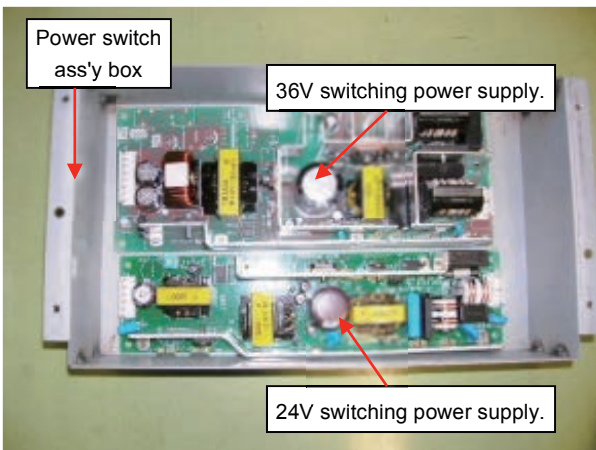

9. Check if Power switch assy box is not set upside down.

Sides where corners are cut shall come to downside. And sides where VRs of Switching Power Supply exist shall come to left.

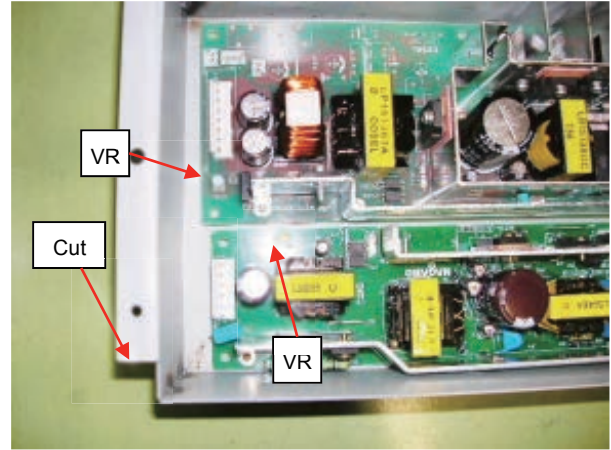

10. Procedures are finished after returning Power Switching

Power Supply back to previous position, wiring and returning Drive A Circuit Board Unit to previous position.

4-4-2 Adjustment voltage output of 24V switching power supply

(Please use digital Tester for this work.)

<Check>

Make sure that power switch is off before this work.

1. Remove outer cover (right), referring to [2-2 How to remove outer cover]

2. Remove outer Cover G ass'y

3. Remove power supply cover A.

Remove the mounting screw as showed bellow.

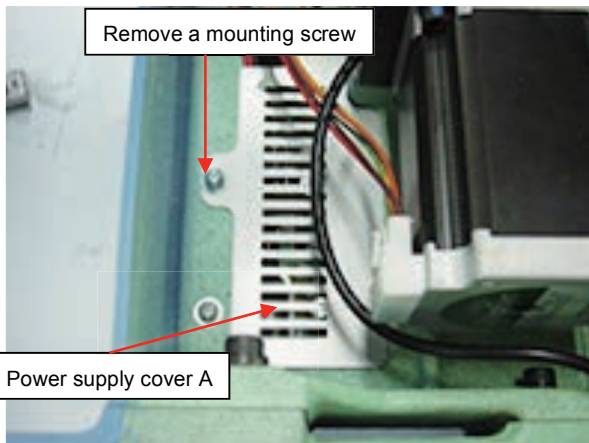

4. Set the digital tester range to DC.

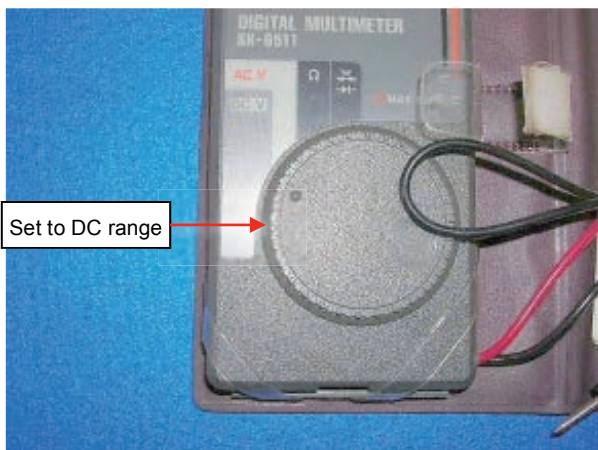

5. Put the probe of digital tester in an optional power connector under the serial port.

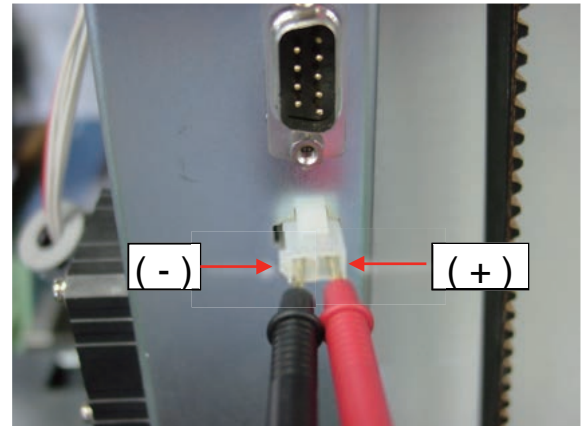

6. Turn on the main switch and set [24.6 V +/- 0.1V] by turning VR (Volume) of 24V switching power supply.

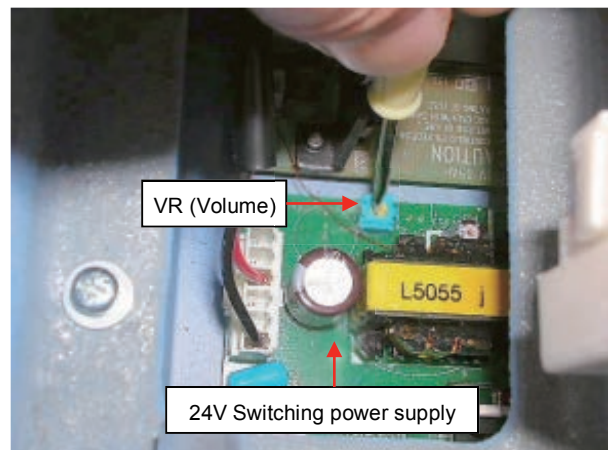

* End of process.

* Put back the cover.

4-4-3 Adjustment voltage output of 36V switching power supply

(Please use digital Tester for this work.)

<Check>

Make sure that power switch is off before this work.

1. Remove outer cover (right), referring to [2-2 How to remove outer cover]
2. Remove outer Cover G ass'y
3. Remove power supply cover A.
Remove the mounting screw as showed bellow.

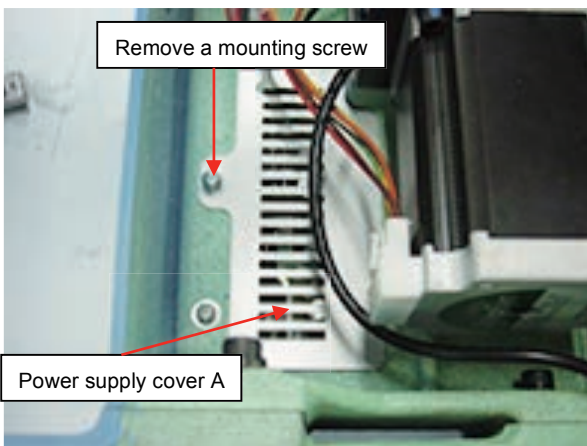

2. Set the digital tester range to DC.

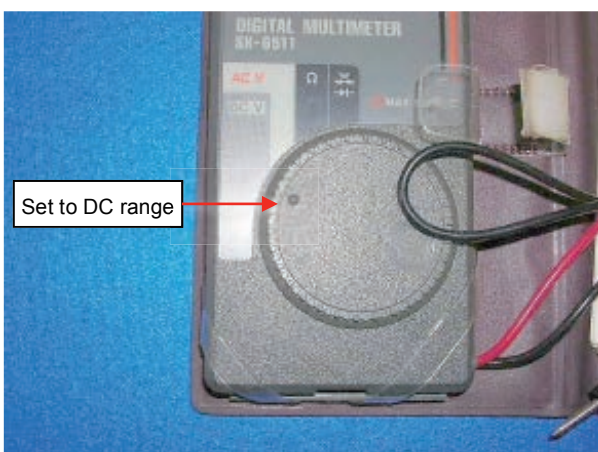

5. Put the probe of digital tester in CN1 (the lower part of the circuit board) of CONT-D2 circuit board.

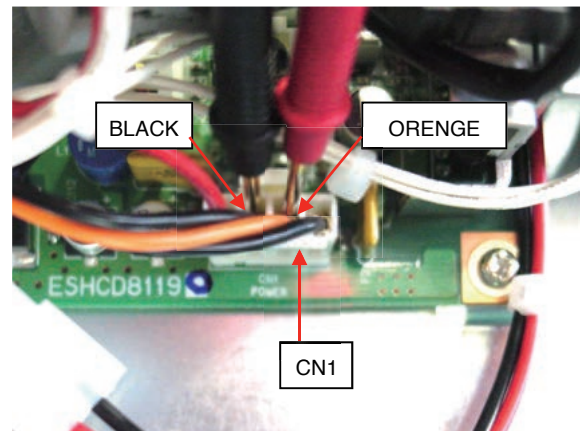

<NOTE>

- * Put RED probe of digital tester in [ORANGE] of CN1.
- * Put BLACK probe of digital tester in [BLACK] of CN1.

- Turn on the main switch and set [36.0V +/- 0.1V] by turning VR (Volume) of 36V switching power supply.

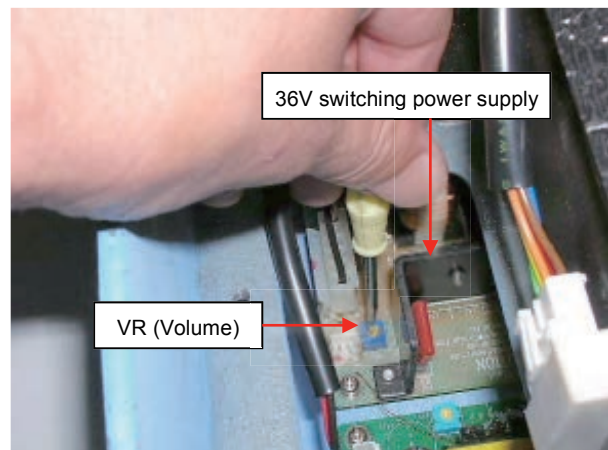

* End of process.

* Put back the cover.

4-4 Exchange of cooling fan

<Note> Disconnect the plug during the work.

CONT-D2 circuit board

1. Remove outer cover (right), referring to [2-2 How to remove outer cover]
2. Remove 2 mounting screws as showed bellow and take out the cooling fan.

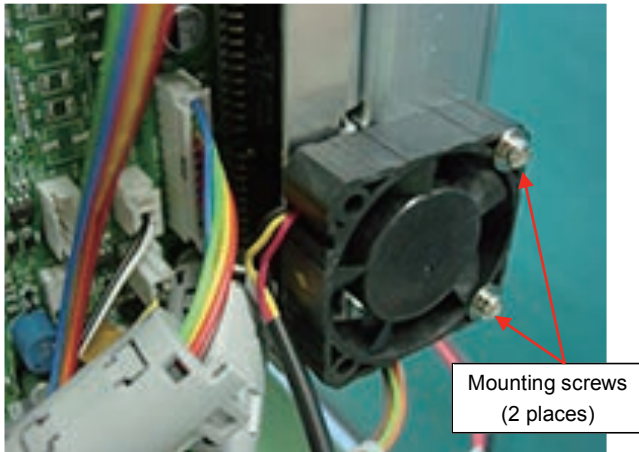

3. Please conform the sticker side and LCD-CE board bracket as showed bellow.

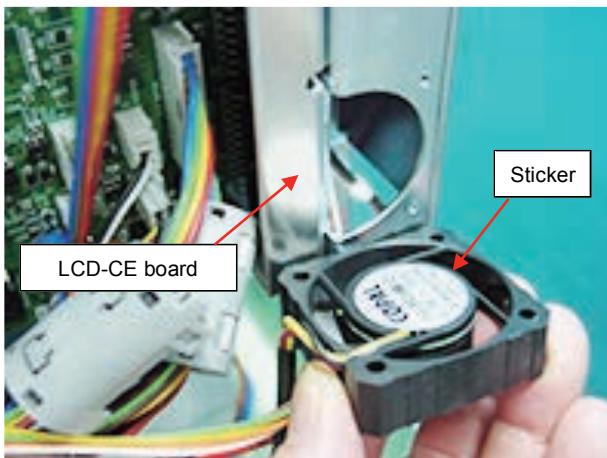

Y pulse motor

1. Remove outer cover (right), referring to [2-2 How to remove outer cover]
2. Remove outer Cover G ass'y and Cover C.
3. Exchange of cooling fan for pulse motor.

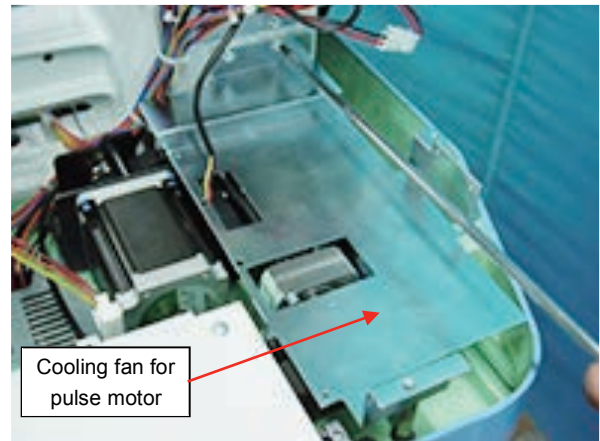

4. Remove 2 mounting screws as showed bellow and take out the cooling fan.

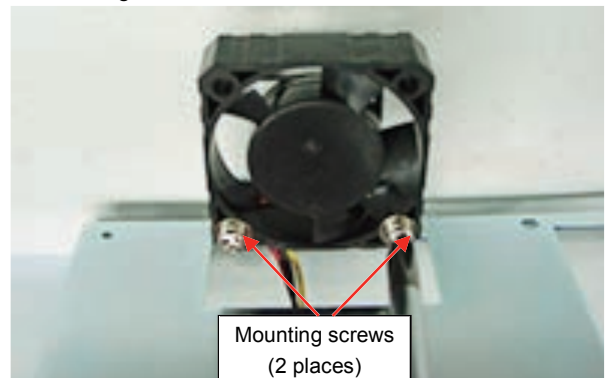

5. When you put replacement cooling fan, turn out the sticker side as showed bellow.

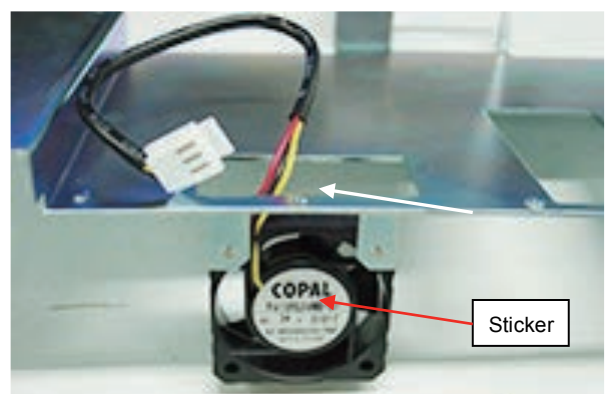

End of process.

Return outer covers to previous positions.

5 Open and remove control box

5-1 Remove control box

<Check> Be sure to turn power switch OFF before work.

1. Remove three setscrews of fixing bracket as shown in the figure below.

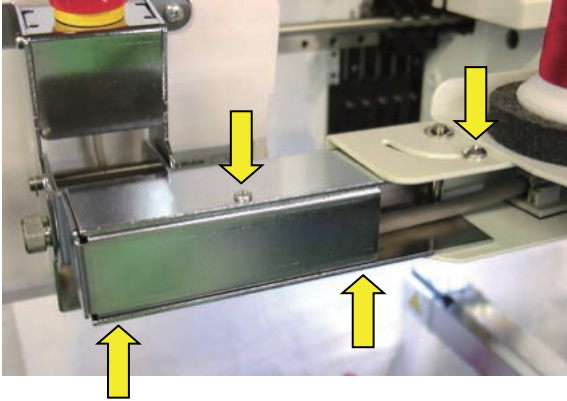

2. Disconnect the connectors indicated by the arrows in the figure below. Remove the screw that fixes cables.

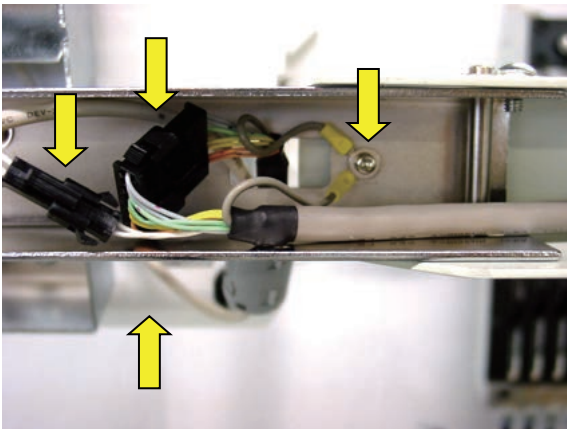

2. Remove Clamp filter.

Remove three setscrews on bracket A as shown in the figure below.

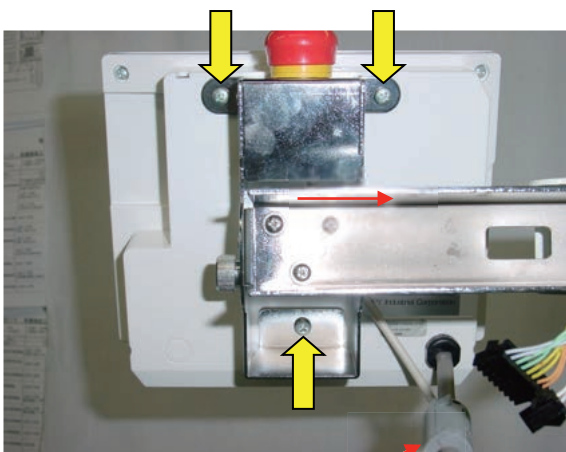

Clamp filter

4. Remove control box.



Please reverse procedure when installing control box.

5-2 Remove LCD-CE board

1. Remove four setscrews as shown in the figure below and remove rear cover.

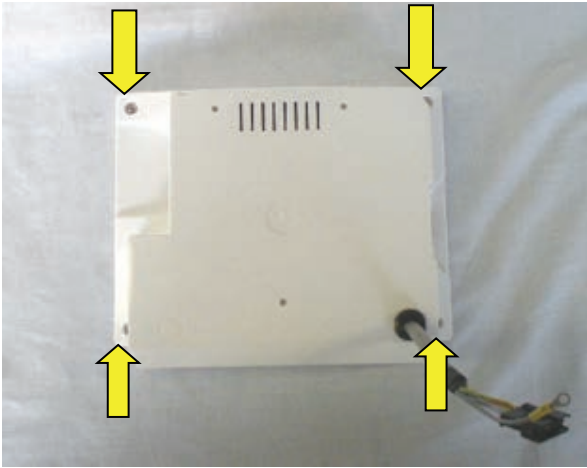

2. Remove connectors for SW cable, Box cable, cable for LCD inverter (red/white).

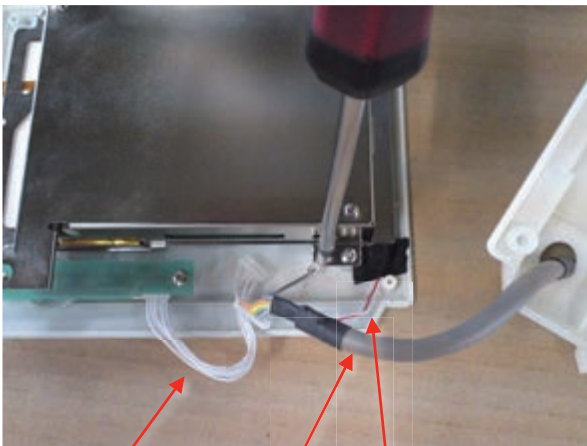

SW cable Box cable
Cable for LCD inverter (red/white)

3. Remove set screw and sealed case A.

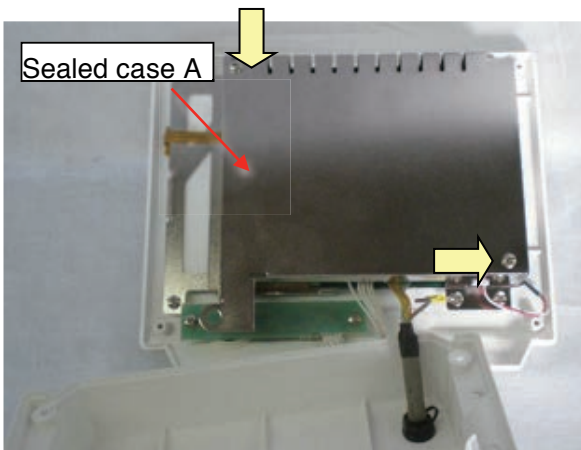

4. Remove core module.



5. Remove narrow flat cable for LCD unit.

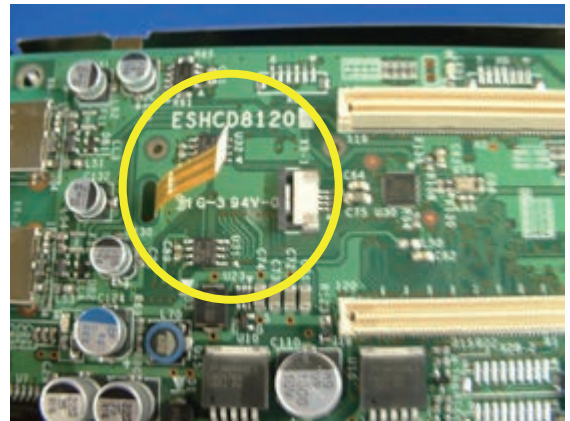

6. Remove two sets screws and two studs.

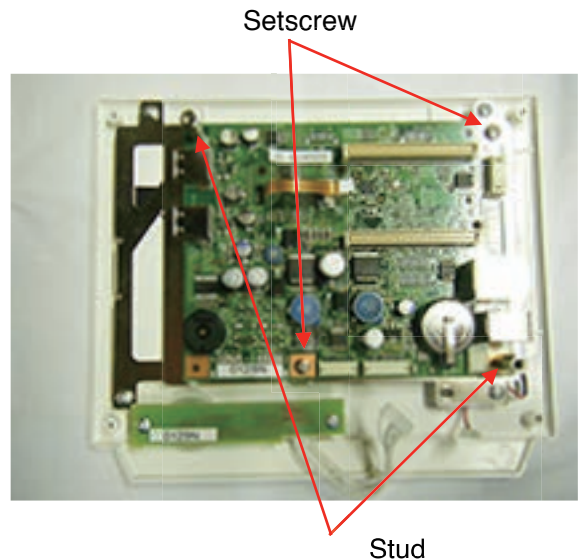

7. Lift LCD-CE board as shown in the figure below.

Remove wide flat cable for LCD unit.

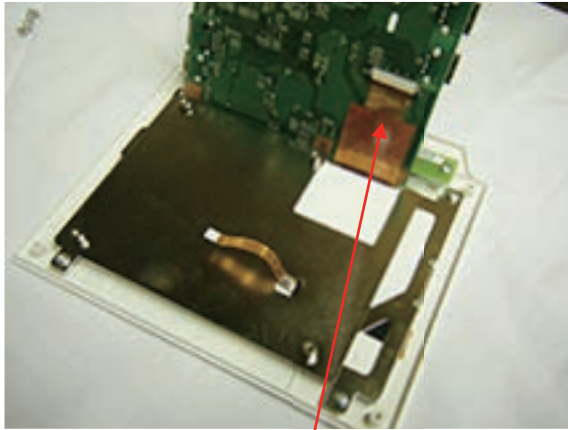

Wide flat cable

8. Remove four setscrews and LCD unit.

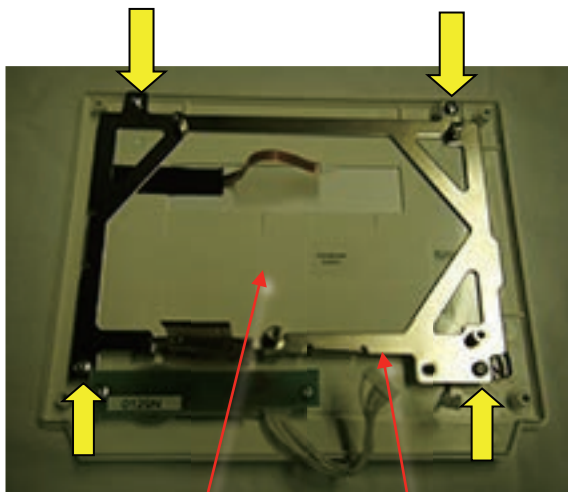

LCD unit

Display

Please reverse procedure when installing LCD-CE board.

5-3 Setting for LCD-CE board

DIP switch (LCD-CE-U)

Switch to OFF on all the settings for DIP switch.

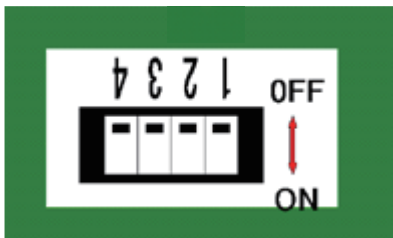
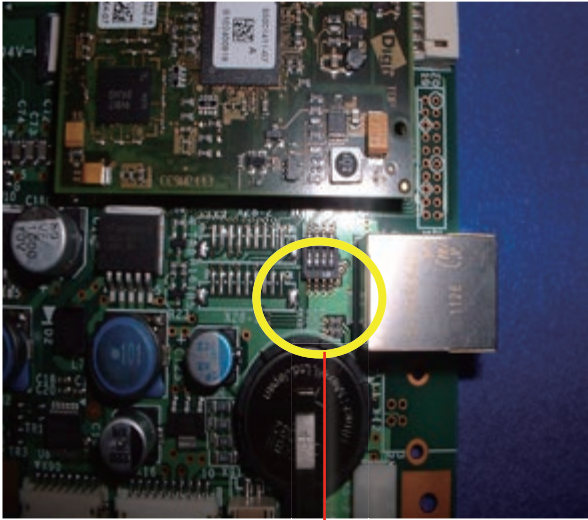

Memory card

Insert our official memory card (EPZ01220). Refer to the latest parts list for the parts number. This memory card contains programs and data for an embroidery machine. You cannot use any memory cards on the market.

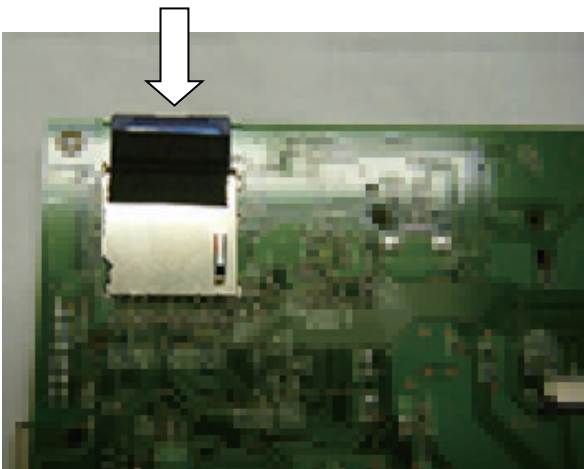

Coin battery

Insert our official coin battery (EPZ01190). Refer to the latest parts list for the parts number. The battery is used for back-up power source of real-time clock on an embroidery machine. Replace new battery if clock dose not indicate the correct time after setting a clock and turning power switch OFF.

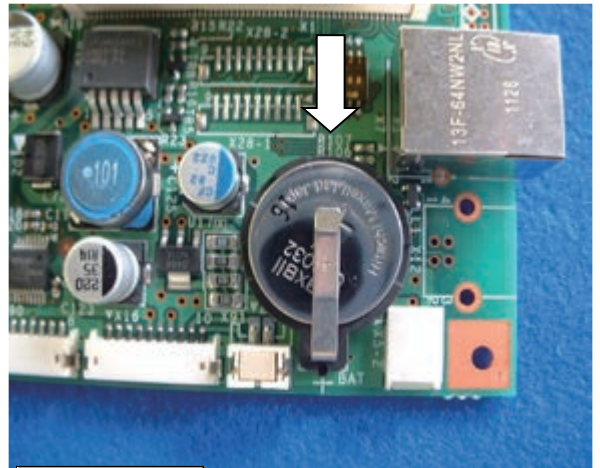

LCD-CE-U

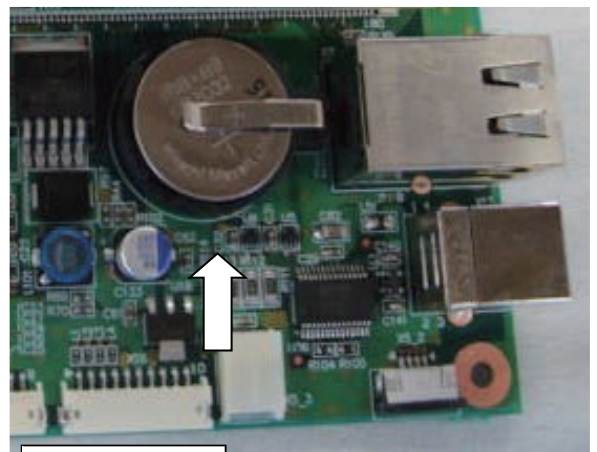

LCD-CE-MX

Disposal of coin battery of LCD-CE board



Dispose of a coin battery by following the method specified by each country or each region.

6-1-1 Remove Inverter

<Notice>

Please disconnect machine inlet from the wall.

<Check>

Before you start to work, make sure the display of inverter is off.

1. Remove outer cover. Refer to [2-2 How to remove outer cover].
2. Remove two screws and inverter with bracket from the machine.
(Be sure not to lose the screws in the machine.)

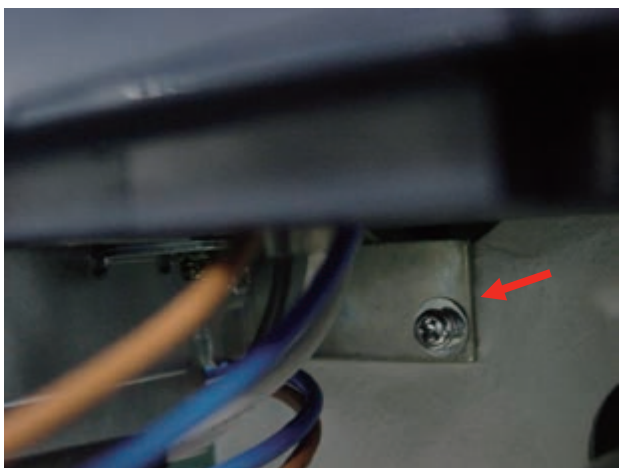

3. Remove two screws shown in the following figure and inverter from bracket.

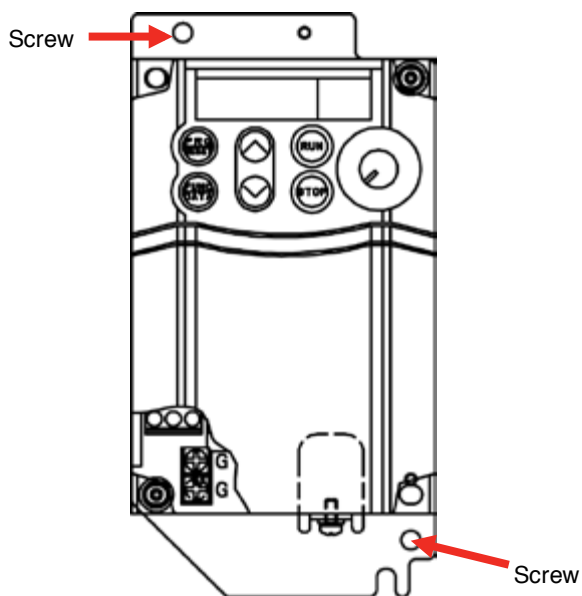

4. Remove cable from clip of the bracket.

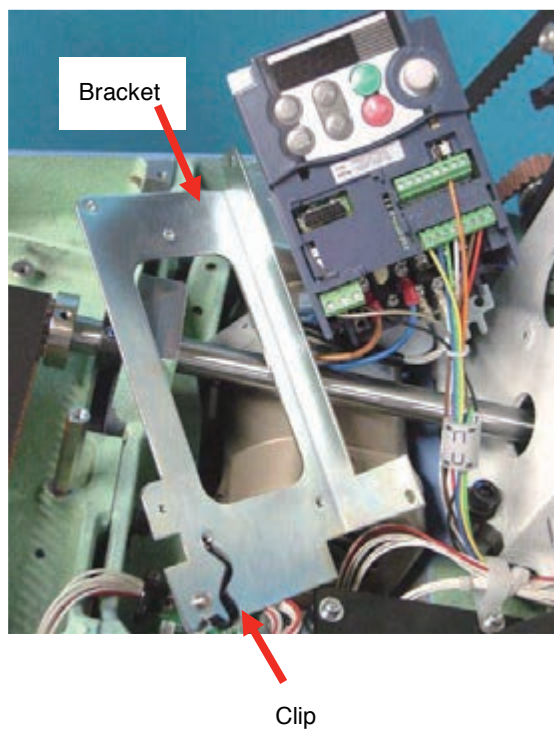

5. Remove control terminal cover.

Insert fingers in a gap (under the "PULL" indication) on the underside of control terminal cover, and pull the cover toward yourself and remove it.

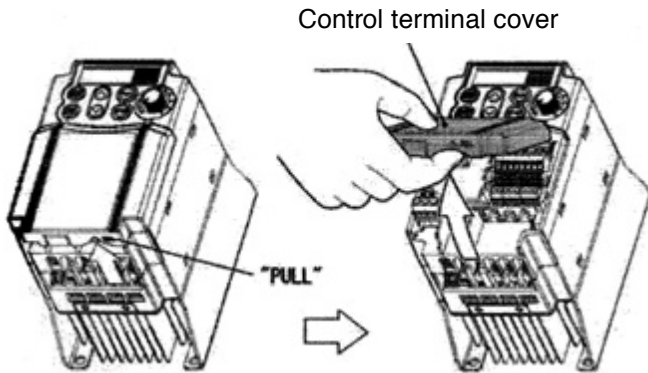

6. Loosen screw with Phillips screwdriver for precision instrument and remove 10 cables. (Cable color: ORANGE, RED, BROWN, PURPLE, WHITE, GREEN, BLUE, YELLOW, BLACK, and GLAY)

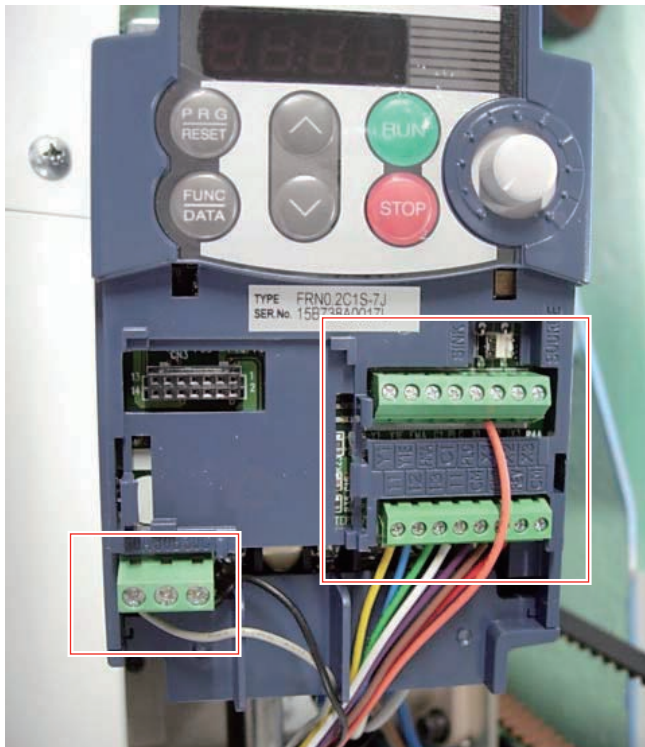

7. Remove main terminal cover

Hold both left and right ends of main terminal cover with fingers and slide the cover toward yourself and remove it.

Main terminal cover

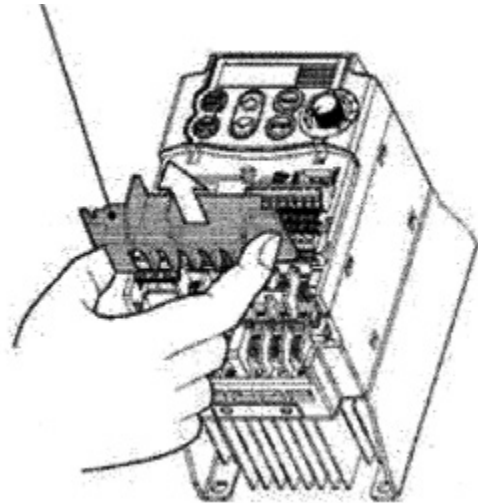

8. Remove screws with Phillips screwdriver and remove power cable and motor cable.

(Cable color: GLAY, WHITE BLACK, BLUE, and BROWN)

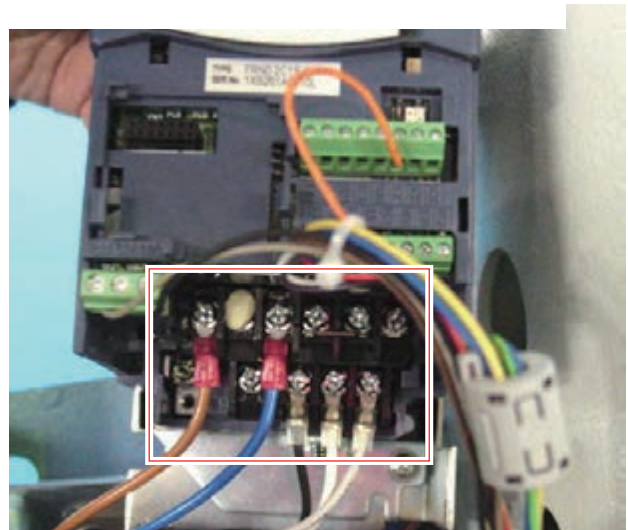

End of process.

6-1-2 Inverter Installation

<Note>

Check if voltage specifications of the machine and inverter are matched before installation.

Sticker on inverter

Inverter for 110 - 120V

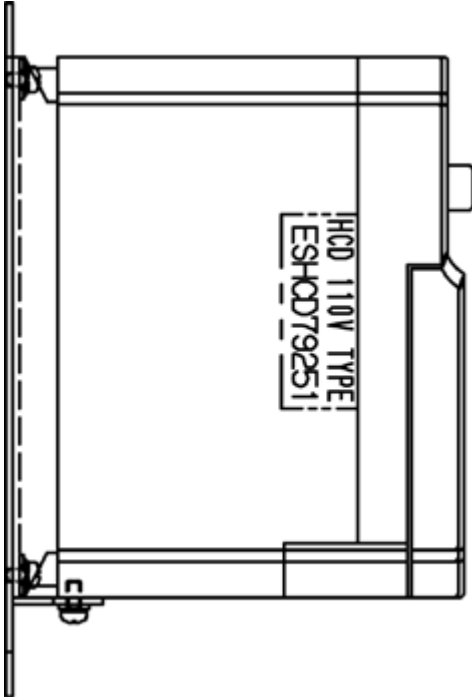

Inverter for 200 - 230V

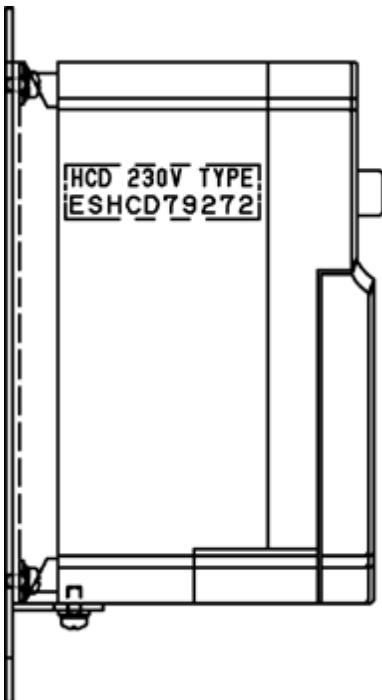

Refer to specification sticker for voltage specifications of the machine.

1. Remove control terminal cover.

Insert a finger in a gap (under the "PULL" indication) on the underside of control terminal cover, and pull the cover toward yourself and remove it.

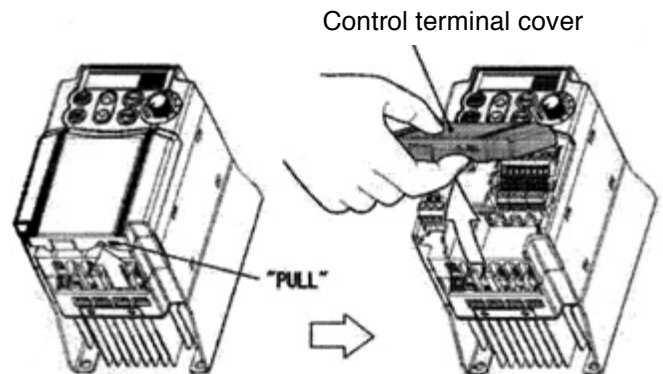

2. Remove main terminal cover

Hold both left and right ends of main terminal cover with fingers and slide the cover toward yourself and remove it.

Main terminal cover

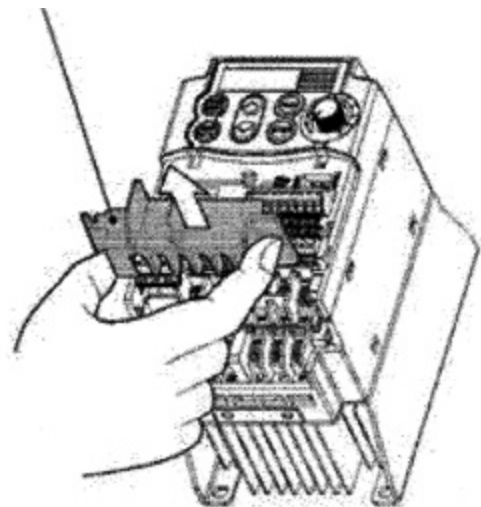

3. Tighten screws with screwdriver to install power cable and motor cable per the following connection diagram.
(Cable color: GLAY, WHITE BLACK, BLUE, and BROWN)

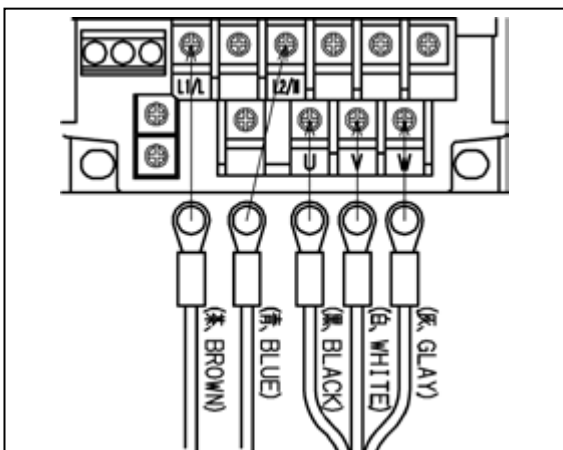
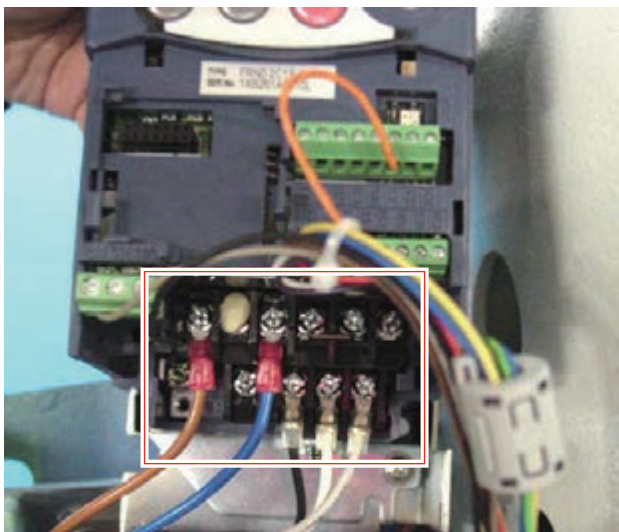

4. Set main terminal cover
Install main terminal cover
Hold both left and right ends of main terminal cover with fingers and install the cover in the inverter

<Note>

Install main terminal cover not to apply stress to the cable. If stress is applied to the cable, load is applied to the screws for the main terminal and the screws might be loosened.

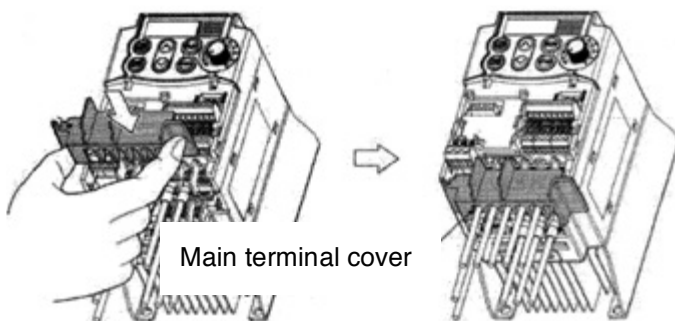

5. Tighten screw and connect 10 cables the following connection diagram. (Cable color: ORANGE, RED, BROWN, PURPLE, WHITE, GREEN, BLUE, YELLOW, BLACK, and GLAY)

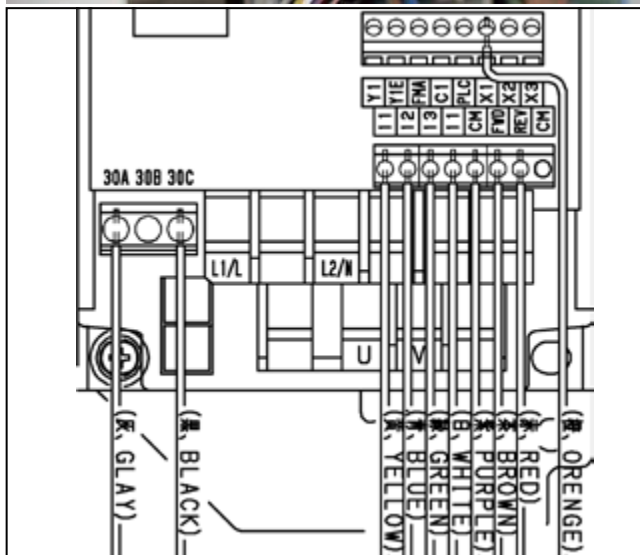
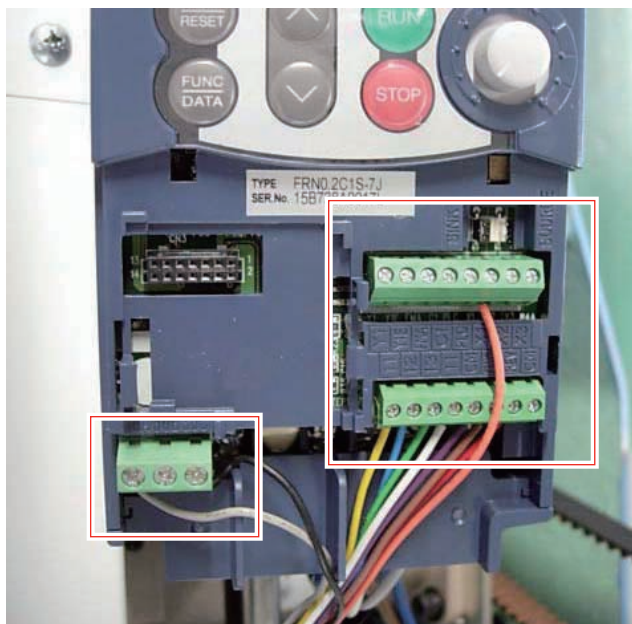

6. Install control terminal cover
Install the cover by inserting the nail on top of the cover to the ditch of the inverter.
Do not pinch any cables with the cover.

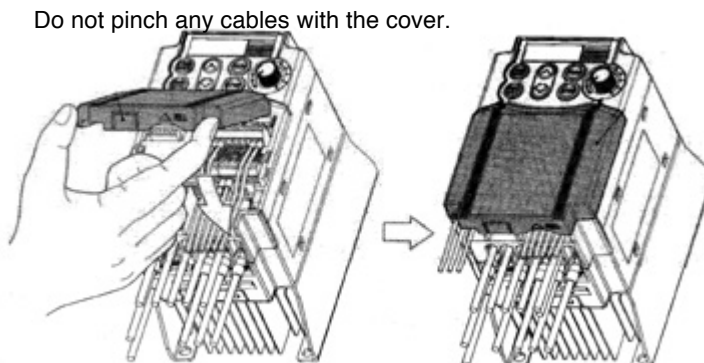

7. Mount bracket in inverter with two screws tightened.
(2 places)

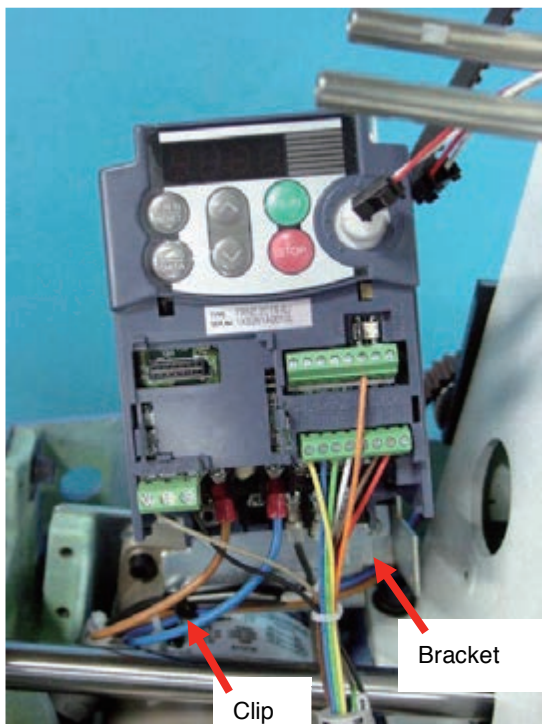
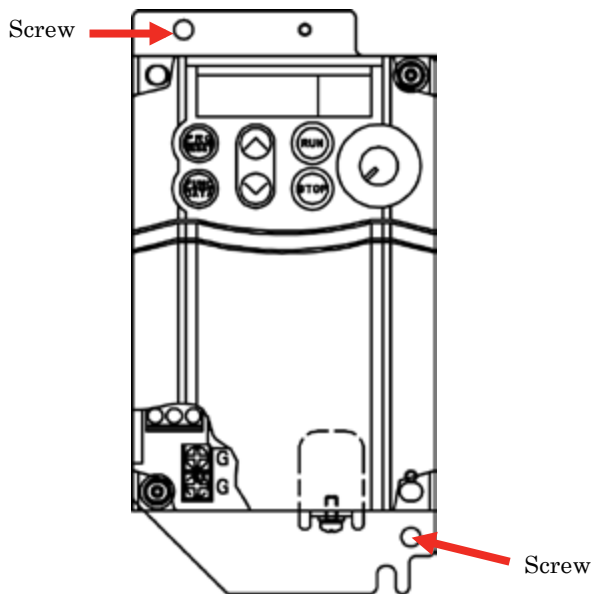

8. Make cables into a bundle with clip.

9. Install inverter in the machine with two screws tightened.
(Be sure not to lose screws in the machine.)

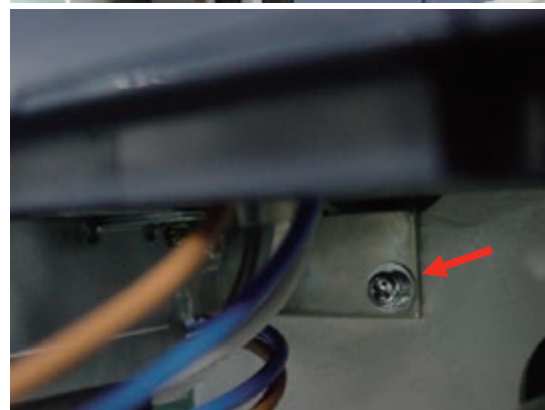

<Note>

Check if voltage specifications of the machine and inverter are matched before installation.

Sticker on inverter

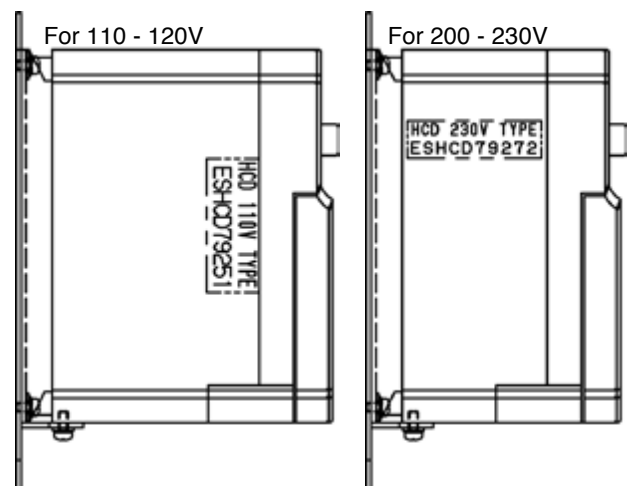

Refer to specification sticker for voltage specifications of the machine.

10. Install the outer cover by following reverse procedure of removing the cover.

6-2-1 How to set inverter

In case of spare parts supply, parameter is preset. Please contact HAPPY, when you need to change it.
 Parameter cannot be set while machine is running .
 Pay attention to electric wires as setting is done with power is on.

How to release the setting change prohibition

Release the prohibition by following the procedures below since parameter is set as setting change prohibition.

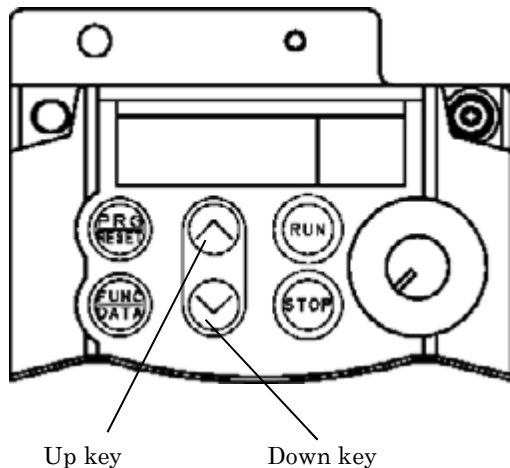

1. Press **PRG/RESET**.
[I.F _ _] is displayed.
2. Press **FUNC/DATA**.
[F 0 0] is displayed.
3. Press **FUNC/DATA** again.
[1] is blinking.
(This means setting change is prohibited.)
4. Press Up key or Down key while pressing **STOP**.
[0] is blinking.
(This means you can change settings.)
5. Press **FUNC/DATA**.
After [SAVE] is indicated,
[F 0 1] is displayed.
By above process, you will be able to set parameters.

Next, change each setting.

6. Press Up key and function code is displayed. Select the function code whose parameter you would like to change.
(Press Down key and the function code returns to the previous code.)

The following table shows function codes, setting details, and factory default setting. Functions other than described below are initial setting of inverter.

Refer to the next clause for the method of initial setting.

Code	Function	→	Setting
F 0 0	Prohibition of change	→	1 (Protect)
F 0 1	Frequency set mode	→	1
F 0 2	Drive / Operation	→	1
F 0 3	Maximum frequency	→	1 2 0 . 0
F 0 5	Base frequency voltage	→	2 0 0
F 0 7	Acceleration time 1	→	2 . 0
F 0 8	Deceleration time1	→	0 . 5
F 1 1	Motor thermal protection	→	1 . 1 0
F 1 5	Upper limit freq. limiter	→	1 2 0 . 0
F 2 0	DC brake. starting freq.	→	1 . 0
F 2 1	DC braking current	→	3 0
F 2 2	DC braking time	→	0 . 5
F 2 3	Start frequency	→	0 . 5
F 2 6	Carrier frequency	→	6
F 2 7	Tone	→	2
F 3 7	Load selection	→	2
C 0 5	Multi stage frequency 1	→	2 . 3
C 3 3	Analog input filter	→	0 . 0 5
C 3 4	Analog input adjustment	→	5 0 . 0
C 5 0	Bias frequency	→	3 . 0
P 0 2	Motor capacity	→	0 . 2 0
P 0 3	Motor rated current	→	1 . 1 0

7. Select the code you would like to change and press **FUNC/DATA**.
Parameter of the function is displayed.
8. Change parameter by pressing Up or Down key.
9. Press **FUNC/DATA**.
After [SAVE] is displayed, the next function code is displayed.
This means change of the function code is made.

How to set the prohibition setting

10. After each setting is done, select [F 0 0] by pressing

Up or Down key to return to setting change prohibition.

11. Press **FUNC/DATA**.

[0] is blinking.

12. Press Up key or Down key while pressing **STOP**.

[1] is blinking.

13. Press **FUNC/DATA**.

After [S A V E] is displayed,

[F 0 1] is displayed.

14. Press **PRG/RESET**.

[I.F _ _] is displayed.

15. **PRG/RESET** again.

Return to normal mode

6-2-2 Initialization of parameter

Please note that you are unable to make this setting while the machine is running.

When setting is mistakenly made in mid way, the setting will return to parameter in normal standard in one action.

Thereafter please change to parameter you want to set.

1. Enable parameter to be changed by referring 1. to 5. in [How to set inverter].

2. Press **PRG/RESET**.

[I.F _ _] is displayed.

3. Select [I.H _ _] by pressing Down key 3 times.

4. Press **FUNC/DATA**.

[H 0 3] is displayed.

5. Press **FUNC/DATA** again.

[0] is displayed.

6 Press Up key while pressing **STOP**.

[1] is displayed.

7. Press **FUNC/DATA**.

After [S A V E] is displayed,

[H 0 4] is displayed.

The settings of inverter become initial settings.

Then, change parameter and return to prohibition setting by referring to the previous clause.

7 Program update procedure

* The sequence of procedures of program update is described below..

If you need more details, please refer to each manual.

-
- | | | |
|---|---|---|
| 1. Insert the updated program downloaded USB memory to the USB port of the machine with its power turned "OFF".
Press NEXT while pressing START/STOP button of the control box at the screen after the machine is booted. | } | 7-2 Update Machine program
7-3 Update Main program |
| <hr/> | | |
| 2. Enter maintenance mode and update machine program and main program from the menu. | } | 8-6 Position—Registration of coordinates for positioning sensor |
| <hr/> | | |
| 3. [Replacement of CONT-D2 board]
Register frame position in Maintenance Mode. | } | 7-3 Initialize machine |
| <hr/> | | |
| 4. Press [MENU] button and select [System] in menu of [OTHER] for initialization of system. | } | 7-3 Initialize machine |
| 5. Press [MENU] button and select [Speed] in menu of [OTHER] for automatic speed setting. | | |
| <hr/> | | |
| 6. [Replacement of LCD-CE board]
Calender setting | | |
| <hr/> | | |
| 7. end of process | | |

7-1 Preparation for program update

* Download updated program file and decompress the file.

Program

for HCD2, HCS2, HCH, HCR2 "MainProgramA**** "

*Copy the decompressed file(s) or the folder that contains decompressed file to USB memory.

File names on your PC are shown below:

Program

for HCD2, HCS2, HCH, HCR2 " UpDateFile"

<NOTE 1>

- Copy the program to the root folder of USB memory.

7-2 Machine program update

1. Insert USB memory that contains data for version up into insertion slot on the control box.



2. Refer to [E5-1 How to enter maintenance mode] and enter maintenance mode. The screen shows below:

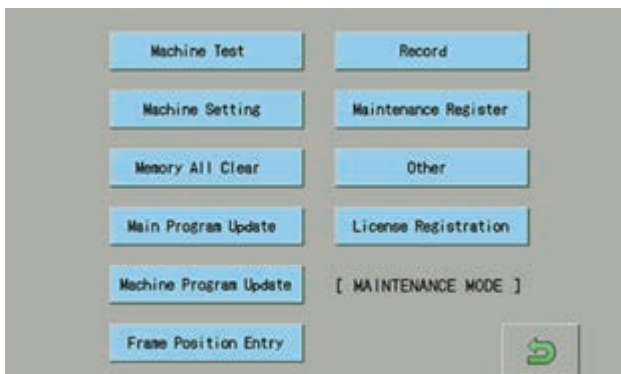

3. Press **Machine Program Update**.

The screen shows contents of the USB memory.

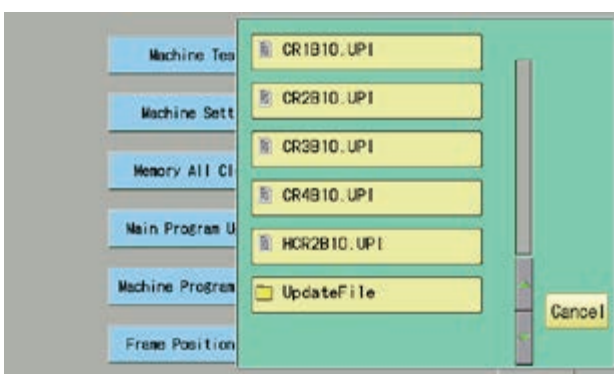

4. Select [UpdateFile].

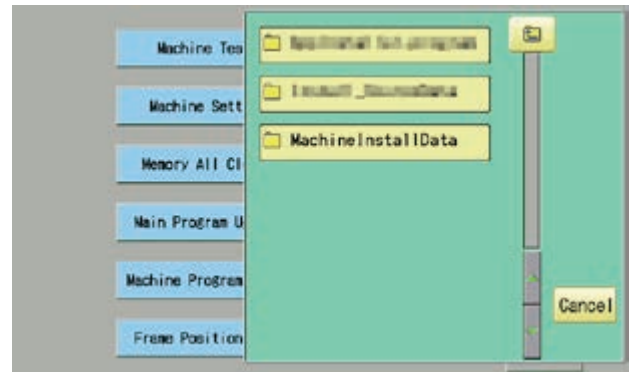

5. Select [MachineInstallData].



6. Select the machine model.

Installation of program begins.

After successful installation, the display will return to step no.2.

<NOTE>

- * Please do not take out USB memory during installation.
- * Please do not turn off the power during installation (it will take for a while for completion of installation).

7. Turn OFF the power and then turn ON the power.

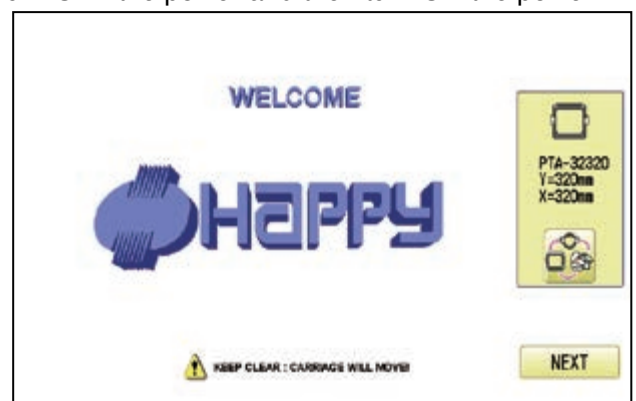

8. Press NEXT.

9. Referring to [7-4 Setting of revolution],
Perform [Re-Initialization of machine system]
And [Initializing of machine speed].

▪ * End of process.

7-3 Main program update (Main program ~Ver.*1.21)

1. Insert USB memory that contains data for version up into insertion slot on the control box.
2. Refer to [8-1 How to enter maintenance mode] and enter maintenance mode. Display comes as below.



3. Press **Main Program Update**.
Select 3 items such as **Language**, **Letter** and and make the screen show "Update" on each item.



4. Press **ENTER**.
Installation of program begins.

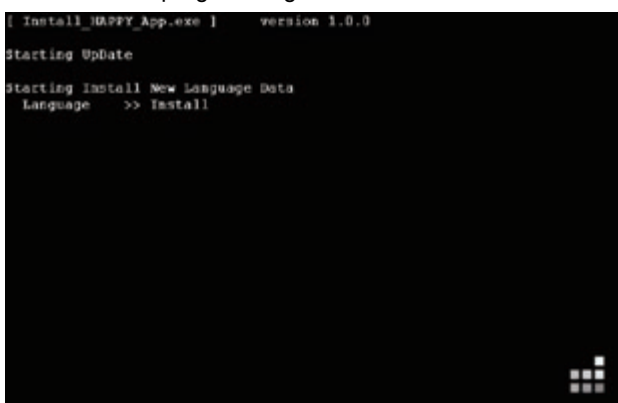

<NOTE>

- * Please do not take out USB memory during installation.
- * Please do not turn off the power during installation (it will take for a while for completion of installation).

Retry updating when the screen shows "Error" due to writing error.

Once update is complete, the machine will be rebooted automatically.





5. Press **NEXT** button.

6. Referring to [7-4 Setting of revolution],
Perform [Re-Initialization of machine system]
And [Initializing of machine speed].

* End of process.

7-3a Main program update (Main program Ver.*1.22~)

1. Insert USB memory that contains data for version up into insertion slot on the control box.

2. Press  (MENU) and press  (OTHER).

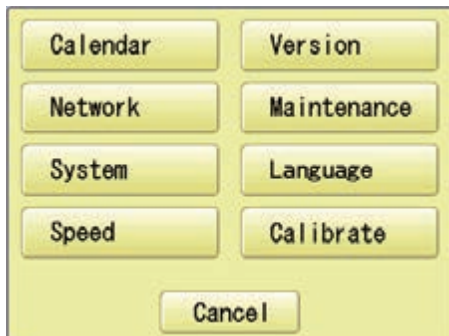

3. Press .

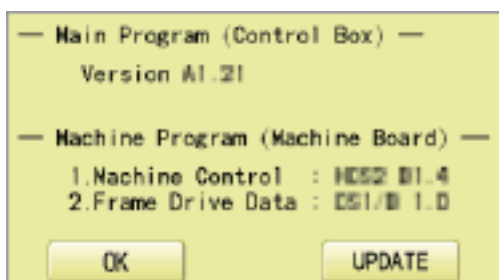

4. Press .

Installation of program begins.

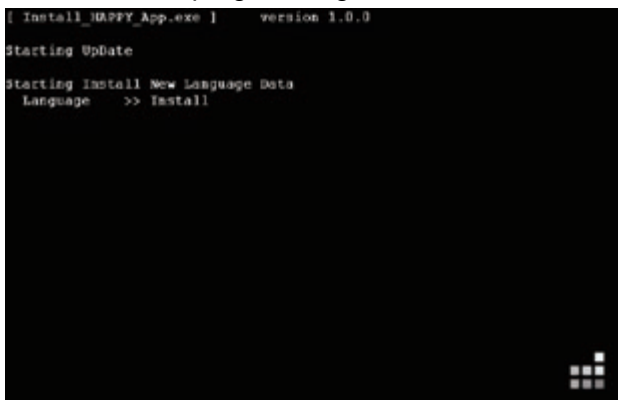

<NOTE>

- * Please do not take out USB memory during installation.
- * Please do not turn off the power during installation (it will take for a while for completion of installation).

Retry updating when the screen shows "Error" due to writing error.

Once update is complete, the machine will be rebooted automatically.



- * Press button.

10. Referring to [7-4 Setting of revolution], Perform [Re-Initialization of machine system] And [Initializing of machine speed].

- * End of process.

7-4 Setting of revolution

Re-Initialization of machine system

Perform this function only to fix problems with the machine.

When performed, all settings in the "OPTION" menu are lost.

Be sure to reset the "OPTION" menu after performing this function.

1. Turn on the power. After the program start up, press

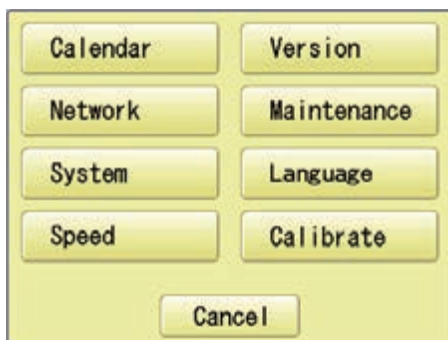

2. Press **System**.

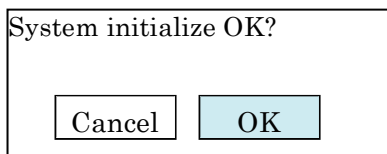

3. Press **OK**.

Formatting of the machines systems are carried out.

Indicate HAPPY logo in screen.

End of process.

Initializing of machine speed

Setting of revolution of main shaft, which is suitable to the machine is required.

If setting is not done, the revolution may not speed up.

1. Turn on the power. After the program start up, press



2. Press **Speed**.

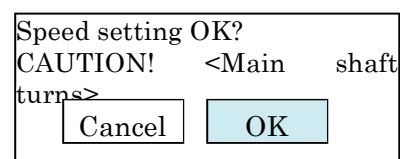

3. Press **OK**.

Main shaft adjusts its revolution speed automatically.

Message **complete** will be displayed when setting is finished and it goes back to drive mode.

End of process.

8 Maintenance mode

Maintenance mode consists of items as shown below.

Machine Test———Movement test, maintenance, and adjustment

Machine Setting———Machine control setting

Memory All Clear———Initialization of design memory.

Main Program Update——Update of operation program and language data

Machine Program Update——Update of control program and frame move data

Frame Position Entry——Registration of coordinates for positioning sensor

Record———Total number of stitches, Error occurrence record, Occurrence record by error type.

Maintenance Register——Registration of machine maintenance date(Normally not used at maintenance)

Other———Other (This item is neither configured nor used.)

8-1 How to enter maintenance mode

1. Turn on machine.



2. Press **NEXT** while pressing **START/STOP** button at the screen of the control box after booting the machine.

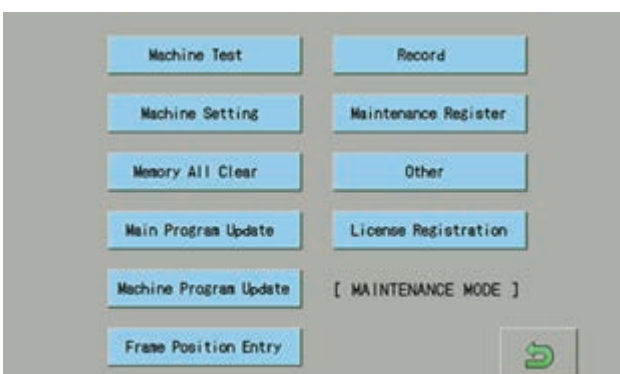

3. Press .



You can enter maintenance mode again by long key

press of  (Menu) at the Drive screen after maintenance mode is finished.

However, you cannot use the reentry method above once the machine is turned off and rebooted.

8-2 Machine—Machine movement

Below operation will be moved solely. In some operations, actuator of motor will be moved, Keep hands and face away during movement for your own safety.



- #1 Input of Needle bar detect Potentiometer
- #2 Action test of moving knife Open-Close
(For adjustment)
- #3 Action test of Thread catch hook
(For adjustment)
- #4 Action test of Keeper solenoid ON-OFF
- #5 Movement test of jump device ON-OFF
- #6 Movement test of thread catch hook IN-OUT
- #7 Action test of moving knife Open-Close
- #8 Action test of clip type thread holder (Option)
- #9 Action test of laser pointer (Option)
- #10 Action test of cooling fan ON-OFF
- #11 Input test of L point / C point timing
- #12 Confirm frame moving sensor
- #13 Confirm registration of frame position data
- #14 Main shaft control test
- #15 Sequin test
- #16 Rotary Hook Adjust (for factory production)
- #17 Needle Posi (for factory production)

1. Enter maintenance mode in reference to [8-1 How to enter maintenance mode]

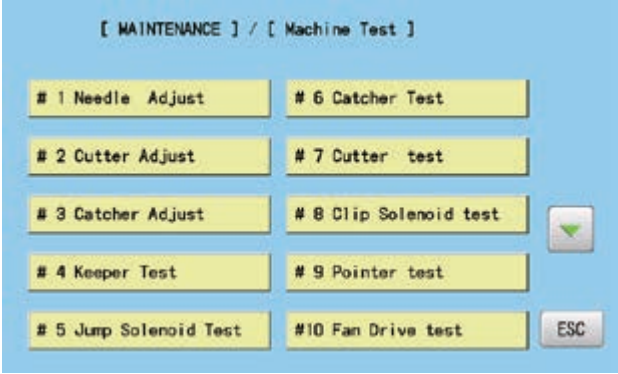
2. Press **Machine Test** .



3. Select desired number to be confirmed.

Page is switched by pressing   .

Selected item will be executed.

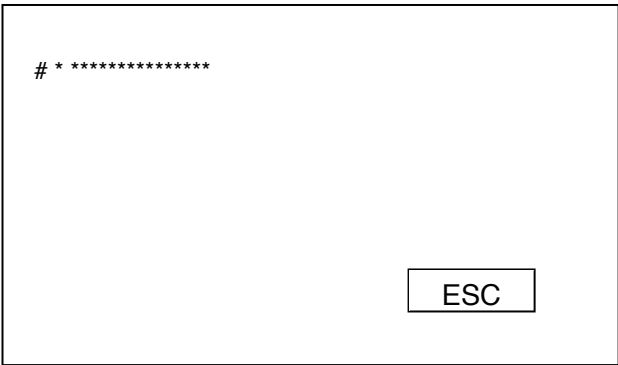

4. The screen returns to the [MACHINE TEST] screen by pressing **ESC** .

(Unnecessary to press **ESC** if the item completes automatically.)

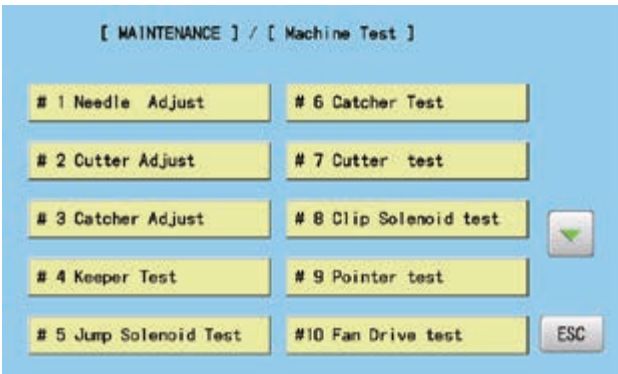

5. Return to drive mode by pressing **ESC** and  .

8-3 Memory All Clear—Initialization of design memory

Delete all the design memory.

Execute this function when occurring design breakage or impossibility of design input.

If abnormality is found after deleting all the data, replace LCD-CE board (or Core module) since the board might be broken.

<NOTE>

All the internal design memory will be deleted by initialization of design memory.

You have to be careful when initializing design memory.

1. Enter maintenance mode in reference to [8-1 How to enter maintenance mode]

2. Press **Memory All Clear** .

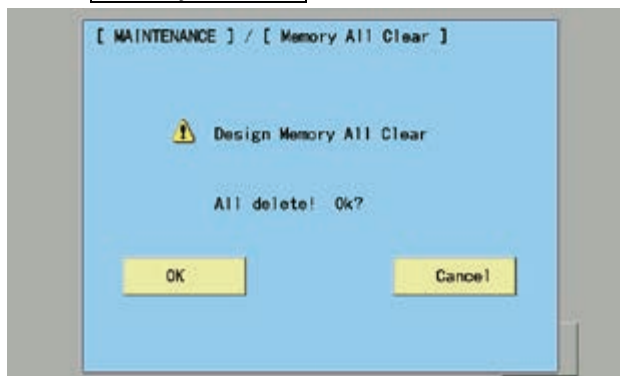

3. Confirmation of free area and all delete will be started after pressing **OK** .

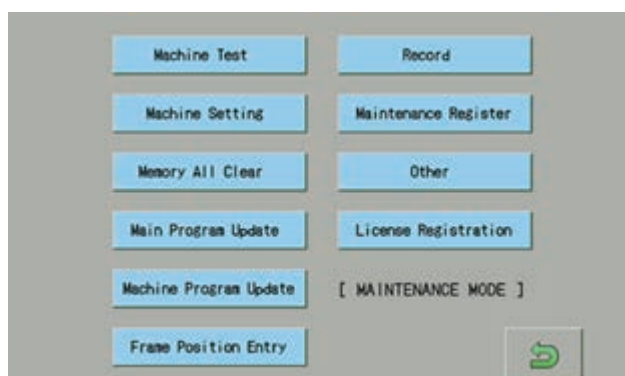

4. Return to drive mode by pressing **ESC** and .

8-4 Record—Operation data display

You can confirm history of operation.

Total number of stitch : Total number of stitch used for embroidery so far

Error occurrence record : Type of errors and its occurrence date

Occurrence record by error type : Accumulated number of each error occurrence

Thread break history : The number of thread break by needle bar

8-4-1 Total number of stitch

1. Enter maintenance mode in reference to [8-1 How to enter maintenance mode]

2. Press **Record**.

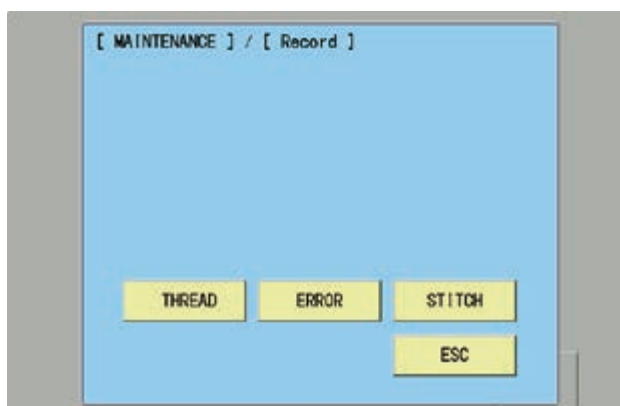

3. Press **STITCH**.

The screen shows total number stitches used for embroidery so far.



4. Selection menu of Clear Total Stitch will be opened when pressing **CLEAR** at Procedure 3.

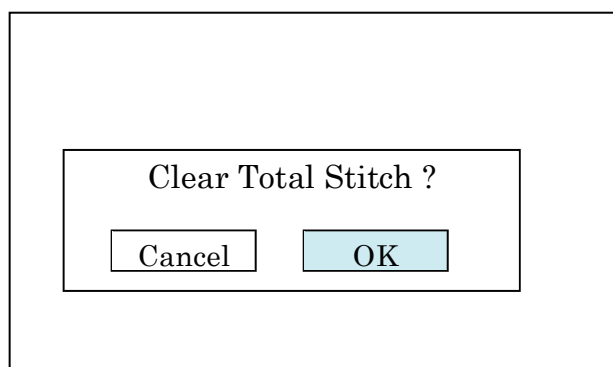

* Total number of stitch is cleared after pressing **OK** and the screen shows one in the procedure 3. Total number of stitch is 0.

* If you do not prefer to clear it, press **Cancel** and the screen shows of the procedure 3 is shown

5. Return to drive mode by pressing **ESC** and .

8-4-2 Record of Error occurrence

1. Enter maintenance mode in reference to [8-1 How to enter maintenance mode]

2. Press **Record**.

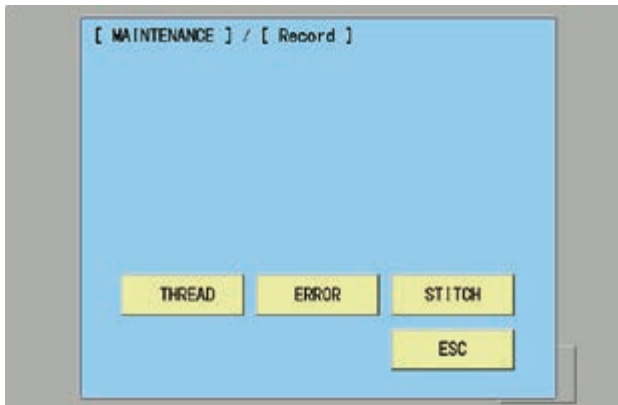

3. Press **ERROR**.

Enable to confirm Record of error occurrence

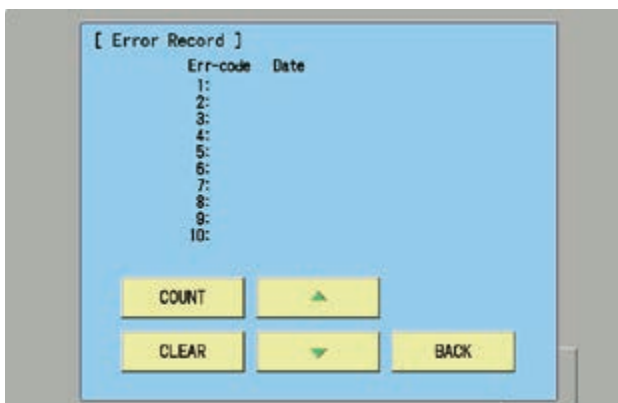

* Enable to confirm Occurrence date and error

number with  button.

Selection menu of Clear Error Record will be opened when pressing **CLEAR**.

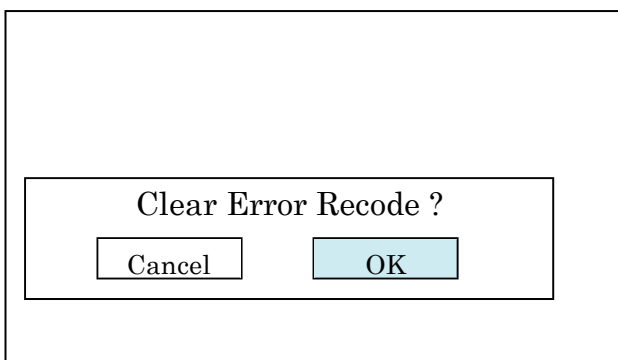

* Error record is cleared by pressing **OK** and the screen of the procedure 3 is displayed.

* If you do not prefer to clear it, press **Cancel** and the screen of the procedure 3 is displayed..

8-4-3 Number of occurrence in each error display

1. Enter maintenance mode in reference to [8-1 How to enter maintenance mode]

2. Press **Record**.

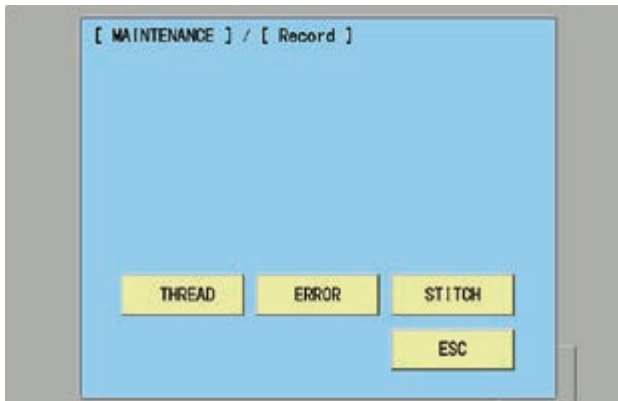

3. Press **ERROR**.

You can confirm record of error occurrence.



4. Press **COUNT**.

You can confirm total number of occurrence in each error.

(E-000 to E-255 will be displayed)

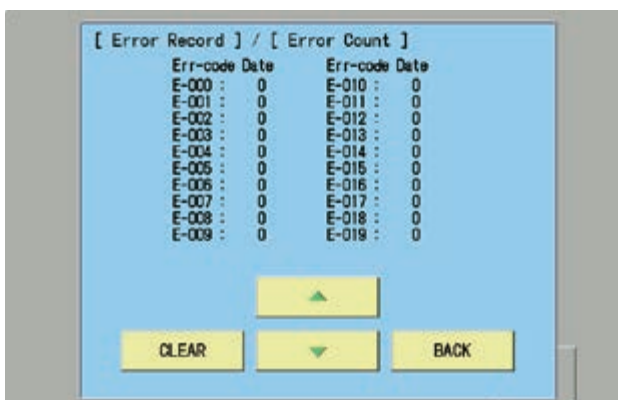

* You can confirm accumulated number for E-000 to

E-255 with  .

* The screen returns to the previous screen by pressing **BACK**.

5. Selection menu of Clear Error Total Count will be opened when pressing **CLEAR** and the screen of procedure 4 is displayed.

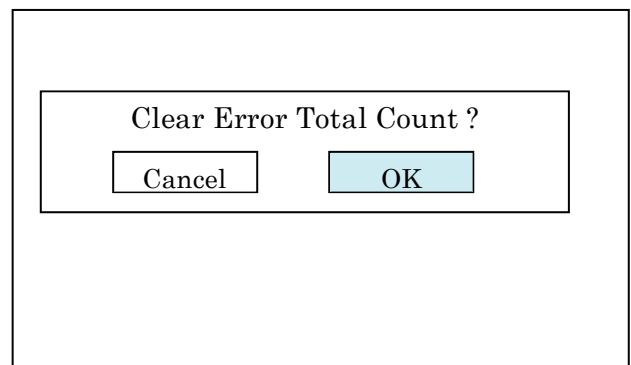

* Error record is cleared by pressing **OK** and the screen of the procedure 4 is displayed.

* If you do not prefer to clear it, press **Cancel** and the screen of the procedure 4 is displayed.

8-4-4 Thread break history

1. Enter maintenance mode in reference to [8-1 How to enter maintenance mode]

2. Press **Record**.

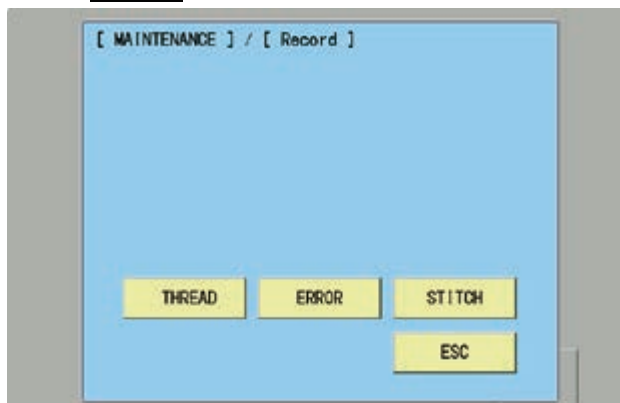

3. Press **THREAD**.

You can confirm thread break history by needle bar.

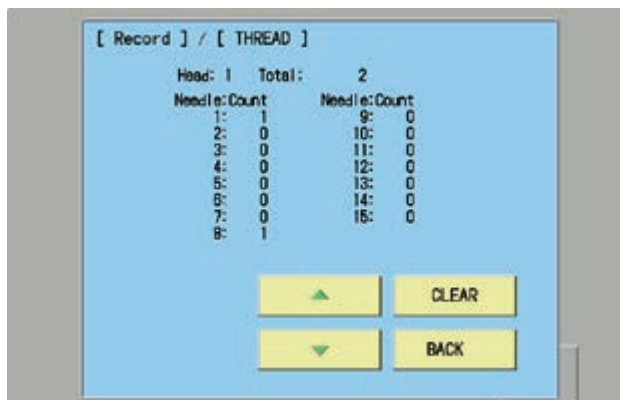

- *The screen returns to the previous screen by pressing **BACK**.

5. Selection menu of Clear Thread Break Count will be opened when pressing **CLEAR** at the screen of procedure 3.

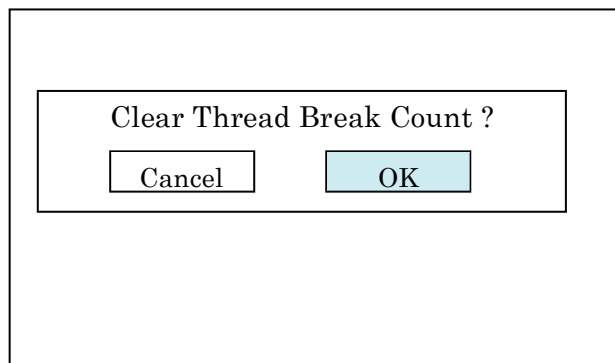

- * Thread break history is cleared by pressing **OK** and the screen of the procedure 3 is displayed.
- * If you do not prefer to clear it, press **Cancel** and the screen of the procedure 3 is displayed.

6. Head is switched by pressing

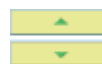

8-5 Setup—Machine setting

<NOTE> (*: Setting is for each individual machine, so prohibit to change setting. When you need to change it, please contact us in advance)

(\$: Setting is different for each model type. Please check before changing data)

(# : Setting is depending on options installed. Please check before changing data)

Contents

* 1	Machine Type	: HC HCD(HCD2)	
* 2	Max Needle Number	: 15 (1-15)	: Number of Needle
* 3	Max Head Number	: 1 (1-30)	: Number of Head
* 4	Machine Max Speed	: 1200 (500-2000)	: Maximum rotation
* 5	Machine Eria X	: 5200 (1-1000)	: Maximum embroidery area at X axis
* 6	Machine Eria Y	: 4000 (1-1000.)	: Maximum embroidery area at Y axis
\$ 7	X Position Sensor	: 6 (0-12)	: Number of position sensor at X axis
* 8	Y Position Sensor	: 4 (0-12)	: Number of position sensor at Y axis
# 9	LED Needle Pointer	: No	: Use of LED Pointer Yes or No
#10	Safety Sensor	: No.	: Use of safety sensor (rear)Yes or No (To be determined)
#11	N.Safety Sensor	: No.	: Use of safety sensor (front) Yes or No
#12	Clip holder device	: No	: Use of Clip holder device YES or NO
* 13	Borer device	: No.	: Use of Borer device Yes or No
* 14	Cutter Unit Type	: PulseMtr	: Thread cutting unit type
* 15	X Start base angle	: 50 (20-90)	: Starting angle of frame movement on X axis
* 16	Y Start base angle	: 50 (20-90)	: Starting angle of frame movement on Y axis
* 17	X Start angle(CAP)	: 50 (20-90)	Starting angle of frame movement on X axis for cap frame
* 18	Y Start angle(CAP)	: 50 (20-90)	Starting angle of frame movement on Y axis for cap frame
\$19	Color Change Speed	: Slow1 (Normal / Slow1 ~ Slow4)	Speed of needle bar change
* 20	Brush Data [*0.1mm]	: 200 (0-250)	Distance of thread brush (mm) after thread cut (1:0.1mm , 200:20.0mm ... 250:25.0mm)
# 21	Clip close timing	: 0 (0-1000)	Close timing of Clip when Thread trim (ms) Set to 200 when the Clip holder device is Yes.
* 22	Border overlap	: 0 (0-10)	Overlap of between heads for border frame
* 23	Trace Needle No.	: 1 (1-15)	Needle Number for Trace
* 24	Device Com. Speed	: 19200bps (2400-115200)	Communication speed for Sequin device and Cording device
# 25	Sequin Dev. Left	: No	Use of left side Sequin device Yes or No
# 26	Sequin Dev. Right	: No	Use of right side Sequin device Yes or No
# 27	Sequin Dev. Type	: Other (Happy)	Type of Sequin device
# 28	Number of 3-Needle	: 0 (0-15)	Needle number of 3-Needle device

1. Enter maintenance mode in reference to [9-1 How to enter maintenance mode].



2. Press **Machine Setting**.



3. Select desired number and modify setting.

- Setting values become default by pressing



- Page is switched by pressing  .

4. Press **ESC** button after modifying of setting number.



5. The screen returns to drive mode by pressing



6. Turn off power and on again before use a machine.

8-6 Position—Registration of coordinates for positioning sensor

This procedure is to memorize embroidery area into the machine.

This procedure has to be done after exchange of CONT-S2 board, position sensor board etc.

(Machine will display error [E-67 Position data] without the registration of coordinate of Position sensor.)

<NOTE>

* Registration should be done with outer cover installed.

Correction position may not be registered if the registration is done without the cover.

* As frame moves at maximum embroidery area, be sure not to have anything around the machine.

1. Enter maintenance mode in reference to [9-1 How to enter maintenance mode]

2. Press **Frame Position Entry** .



Operate according to displayed below message.

- (1). Fix carriage cover
- (2). Remove cap frame
- (3). Move frame to center mark position by



(Refer to below display)

- (4). Press **START** button

(Press **ESC** button in case of cancellation)

3. When you press **START** , register X axis direction first.
Frame moves in the numerical order as shown in the following figure.

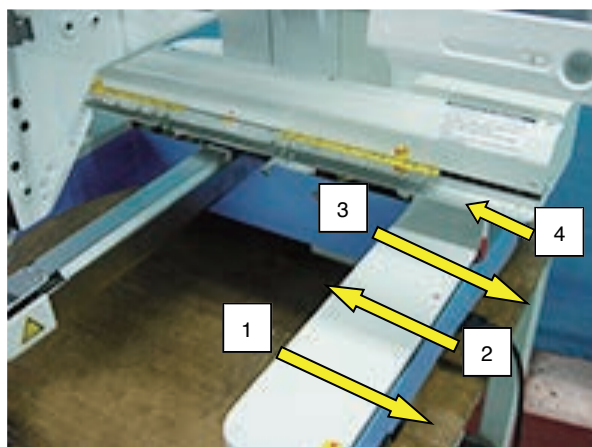

Center mark position of X axis



Center mark position of Y axis

4. Then register Y axis direction. Frame moves in the numerical order as shown in the following figure.

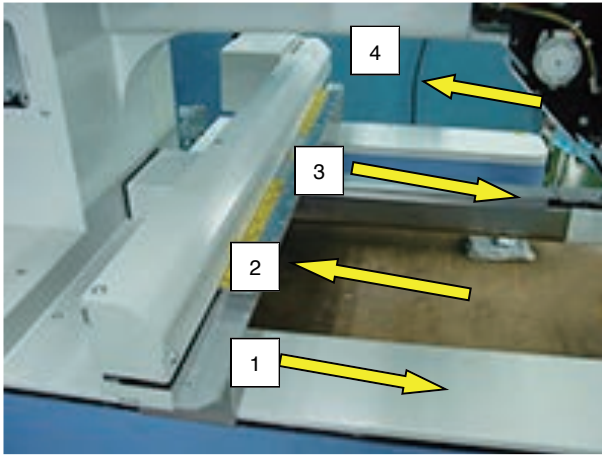

5. Below message will be displayed with successful completion.

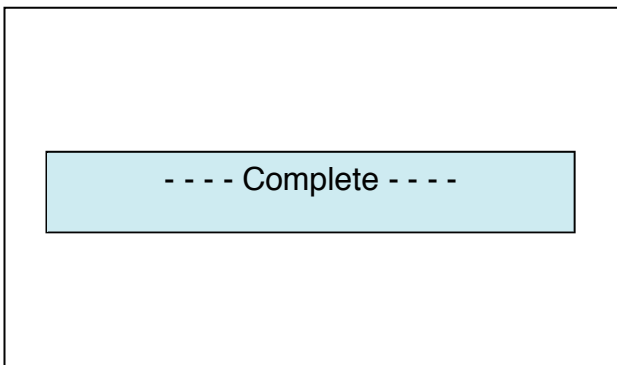

* Retry from procedure 2 if [Error] occurs.

Frame position registration is finished.

6. Return to drive mode by pressing **ESC** and .

9-1 Installment, setting and adjustment of safety sensor

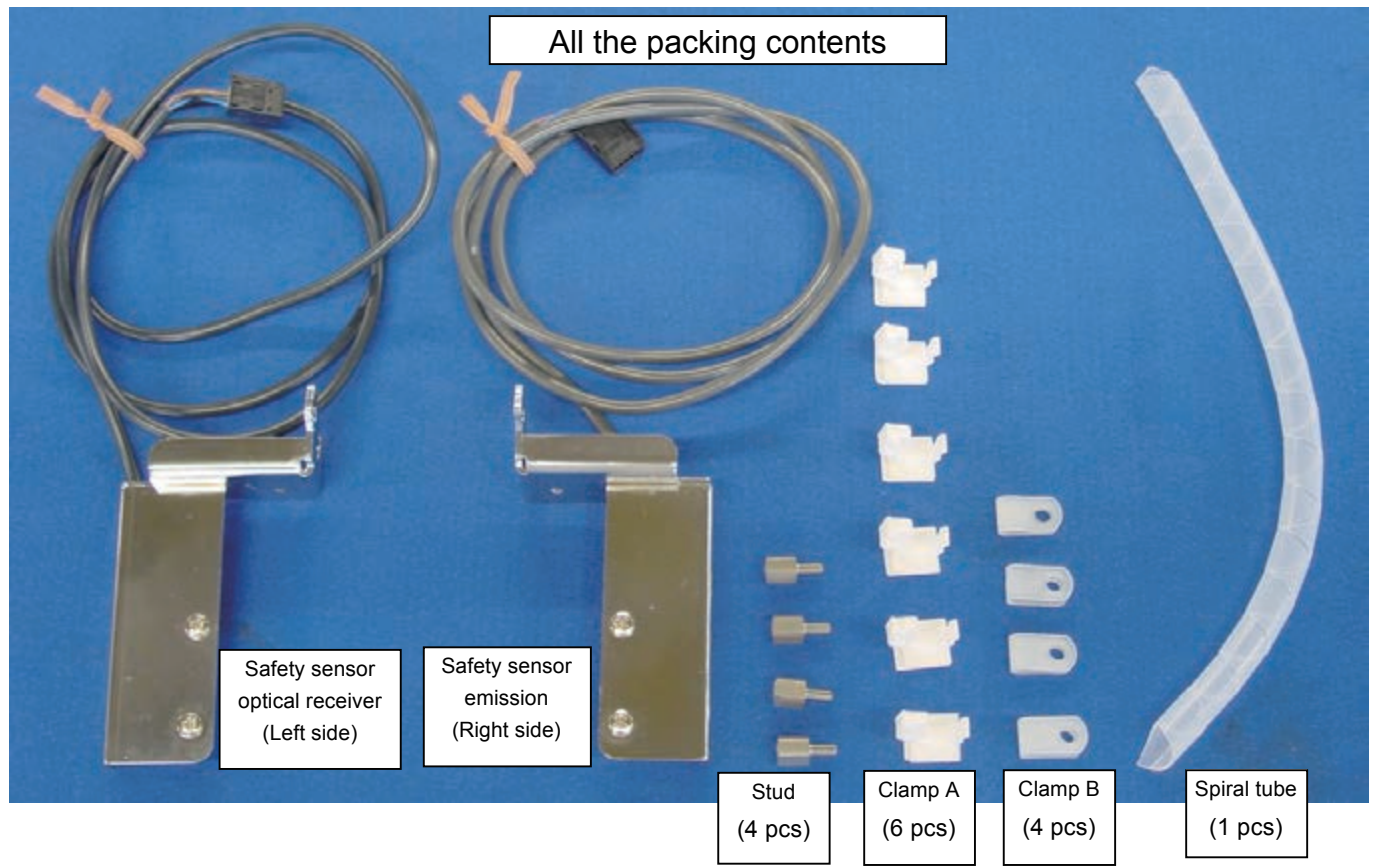

9-1-1 Installment of safety sensor

For your own safety make sure to unplug cord from receptacle.

1. Remove mounting screws.

<NOTE>

Do not remove 2 screws at the same time.

After removing 1 screw, go to the step 2.

If 2 screws are removed at the same time, position adjustment for holder is required.



2. Fix stud bolts to the position where the screws are removed at the step 1.

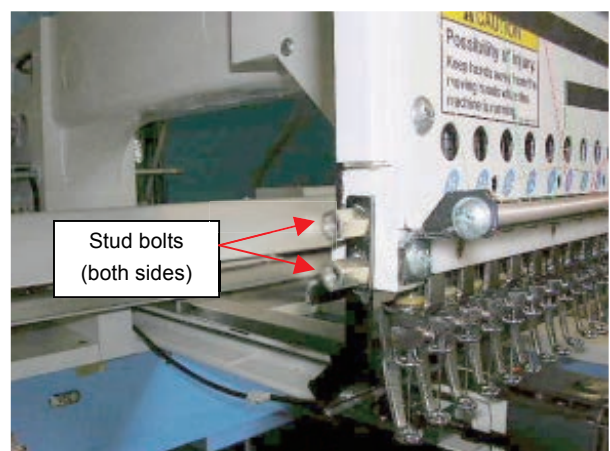

- Fix safety sensor optical receiver to the stud on the left side with the mounting screws removed at the step 1.

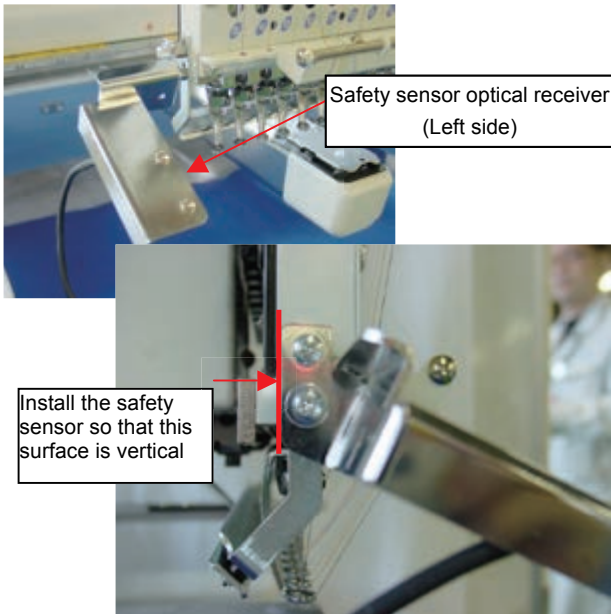

- Fix safety sensor emission to the stud on the right side with the mounting screws removed at the step 1.

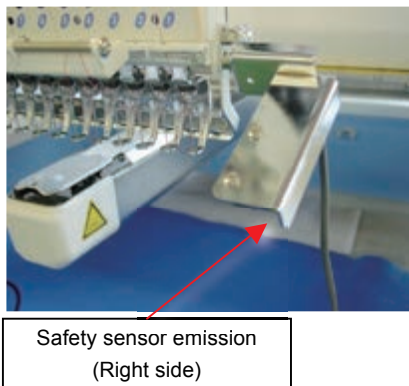

- Attach clamp A to fix head on both right and left sides. (Total 6 places)

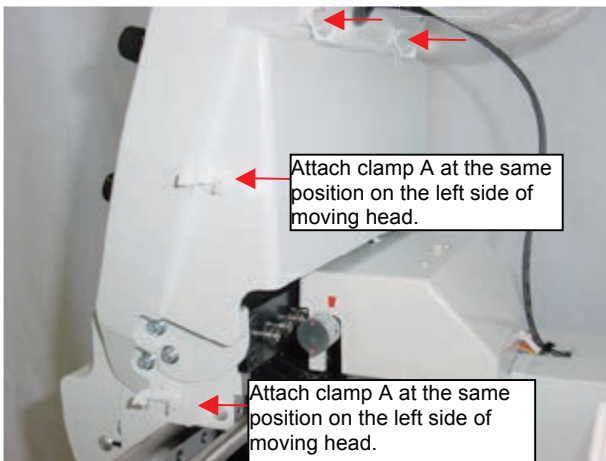

- Remove screws fixed on needle bar boss check plate and fix the safety sensors' cord and Clamp B with the screws on both right and left sides.

<NOTE> Lace the cord through concave portion of safety sensors.

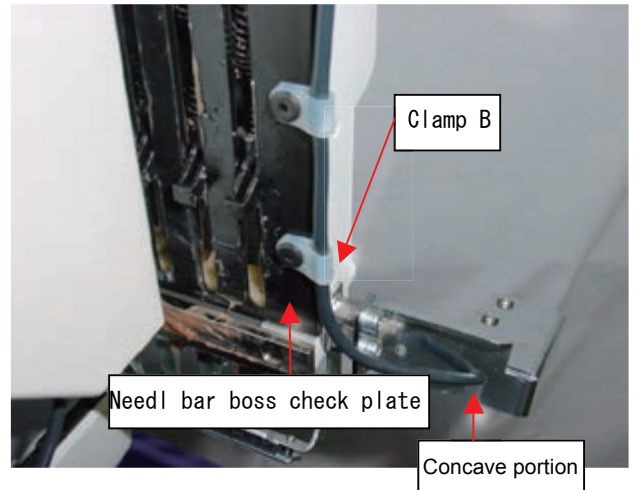

- Fix safety sensors' cord with clamp A on both right and left sides.

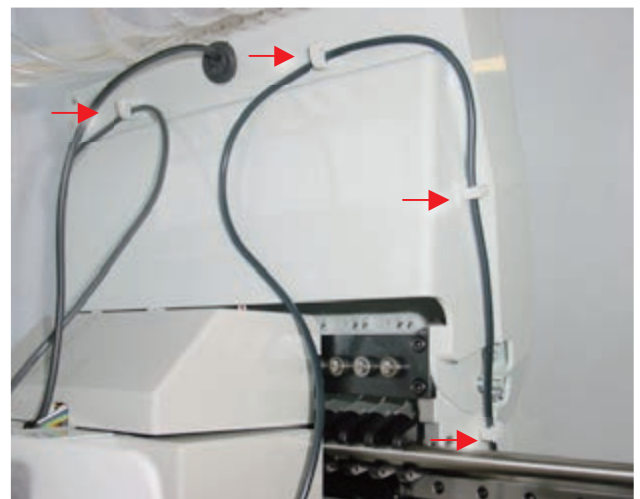

- Remove 2 screws and arm upper cover.

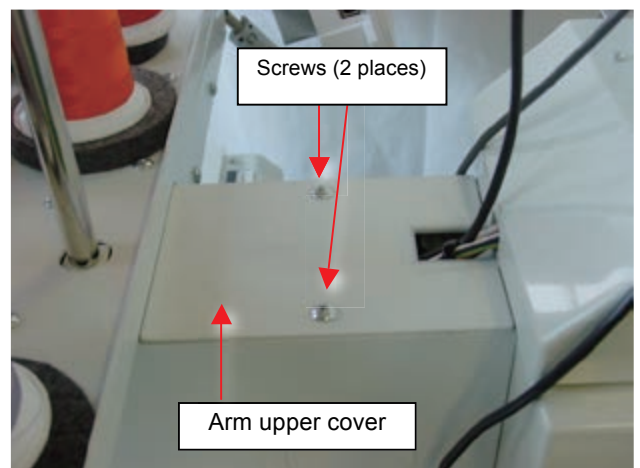

9. Insert safety sensor optical receiver cord into the small connector and insert safety sensor emission cord into the large connector.

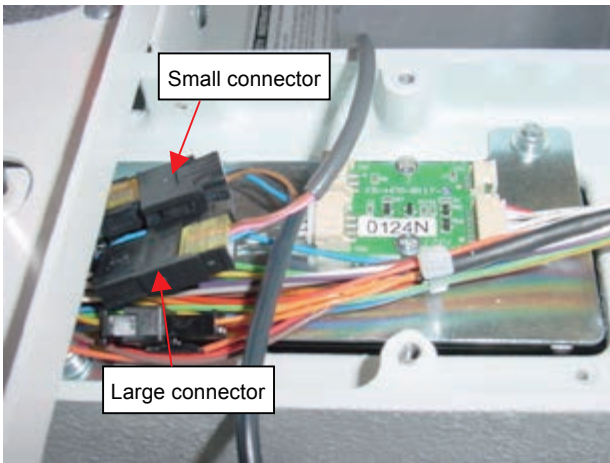

10. Fasten safety sensor cord and TC cable together with spiral tube.

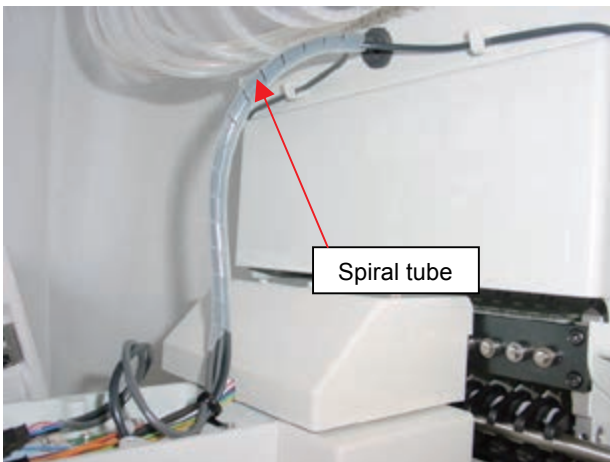

11. Fix safety sensor cord and other cord together with clip.

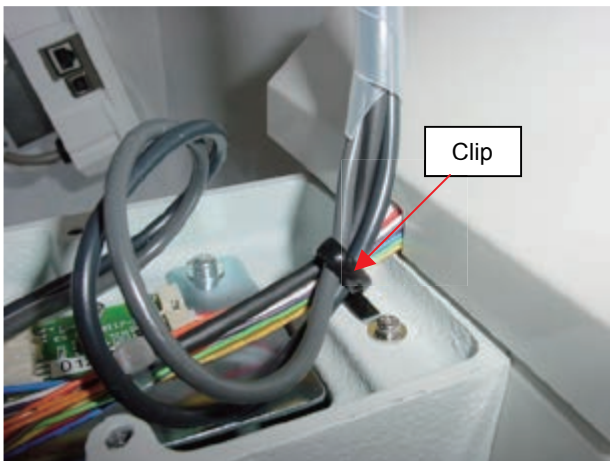

12. Fix Arm upper cover.



End of process

9-1-2 Setting procedure



1. Turn on machine.
2. To access maintenance mode, press **NEXT** while pressing **START/STOP** button at the startup screen of the control box after booting the machine.

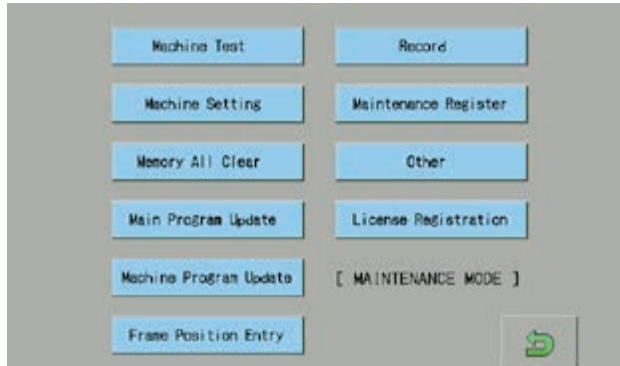

3. Press **Machine Setting**.





4. Select "YES" on 11 [N. Safety Sensor]

Page is switched by pressing  .

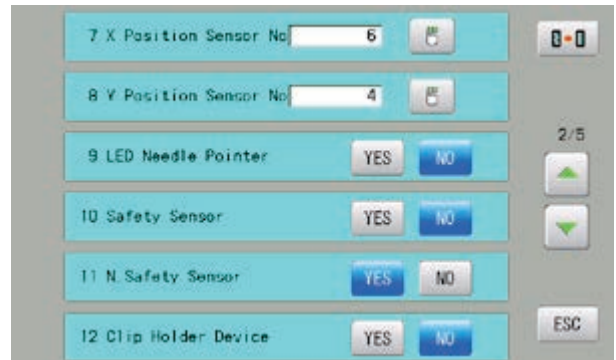

5. After safety sensor setting is complete, return to the [MAINTENANCE MODE] screen by pressing **ESC**.



6. To return to the startup screen, press .

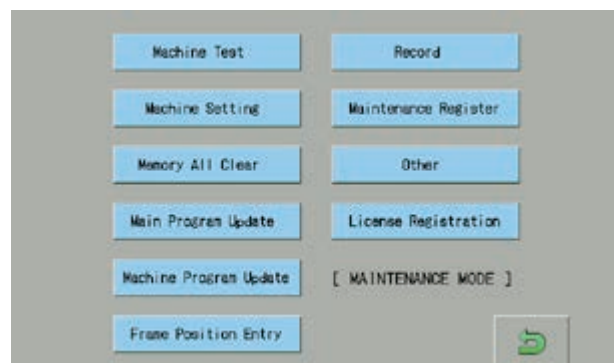

Safety sensor setting procedure is done.

次に、sensor の adjustment of optical axis を行って下さい。

9-1-3 Adjustment of Optical axis

1. Loosen screws that are fixing Safety sensor optical receiver (Left side).

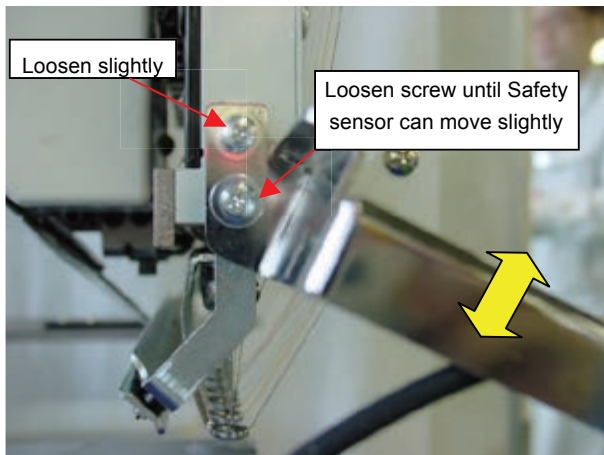

2. To be sure that the way of sensor ray is not blocked. Then, adjust the optical receiver to correct position that the LED (Orange) light stable as picture below.

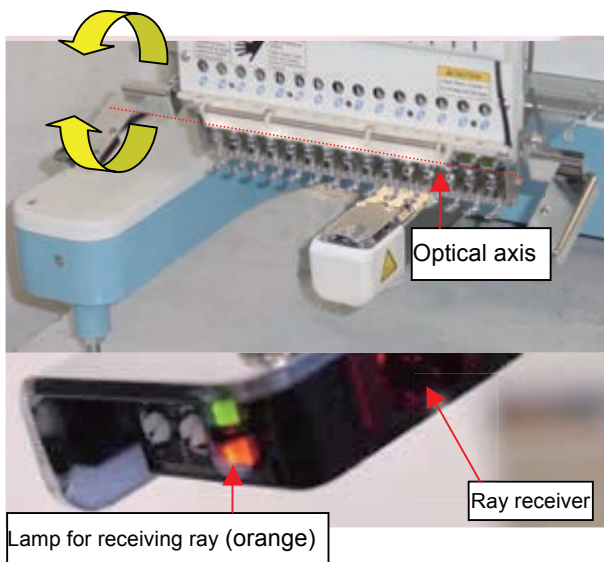

3. Fix screws that are fixing Safety sensor optical receiver (Left side).

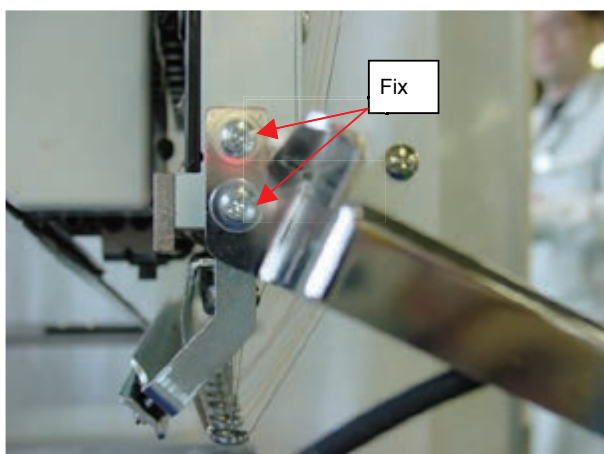

4. Confirm of operation check.

Block Optical axis of Needle sensor at drive mode (Use screwdriver or something)

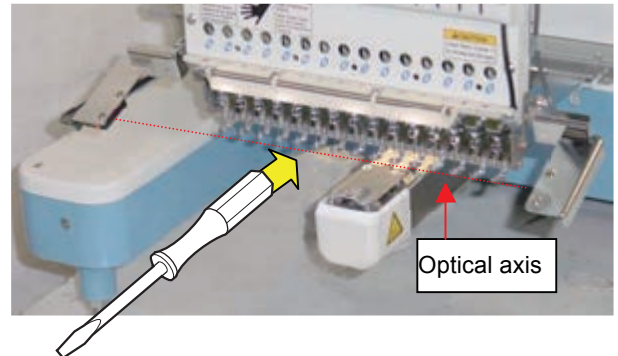

5. Press **Start** button.

Below error will be displayed and Machine won't start if Needle sensor works properly.

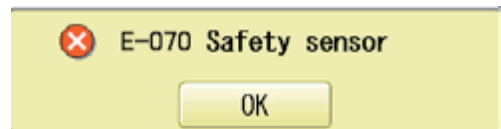

Press [OK] to release the error, then adjustment is completed.

In some cases, you may need to adjust sensibility of the receiver.

Please note that factory default setting of sensibility volume (right side) is "middle" as picture below.

If the safety sensor detects upper thread, the adjustment of receiver is too sensitive.

In such case, slightly turn the volume to [min] direction.

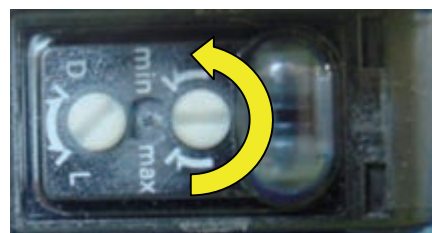

If the safety sensor does not detect even finger, the sensibility of the receiver is too low.

In such case, slightly turn the volume to [max] direction.

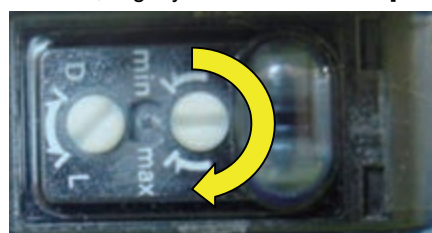

Adjustment of Optical axis is done.

9-2 Installment of Bobbin winder

* Install Bobbin winder

Remove outer cover left. Refer to [2-2 How to remove Outer cover left]

* Confirm all the necessary items are ready.

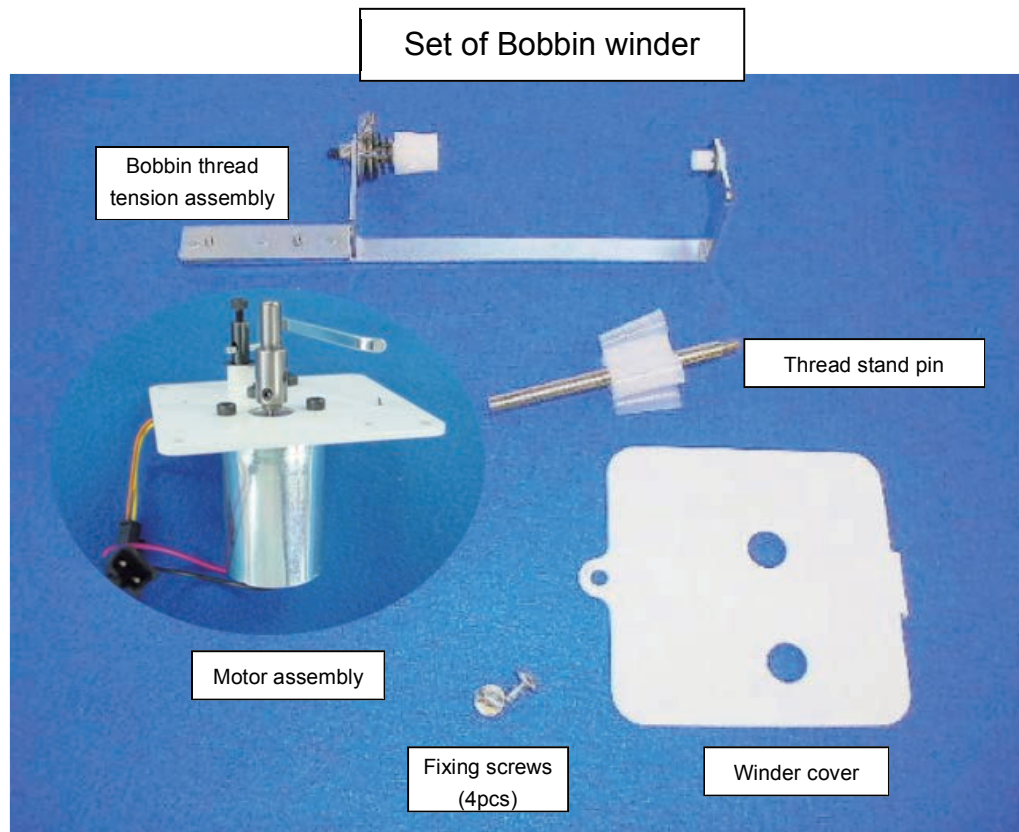

1. Remove Guide from Bobbin thread winding motor assembly. Remove with hexagonal wrench. (In order to avoid interference at the time of installation of cover.)

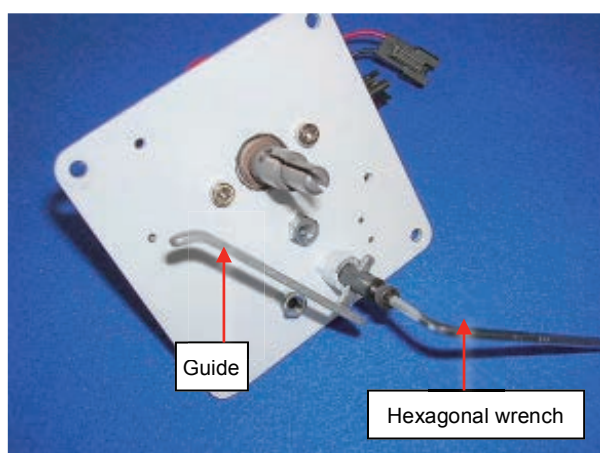

2. Install Bobbin thread motor assembly as the picture below with attached screws.

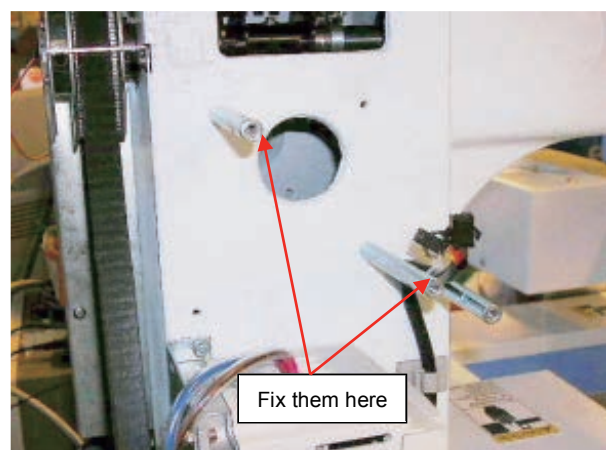

3. After installment

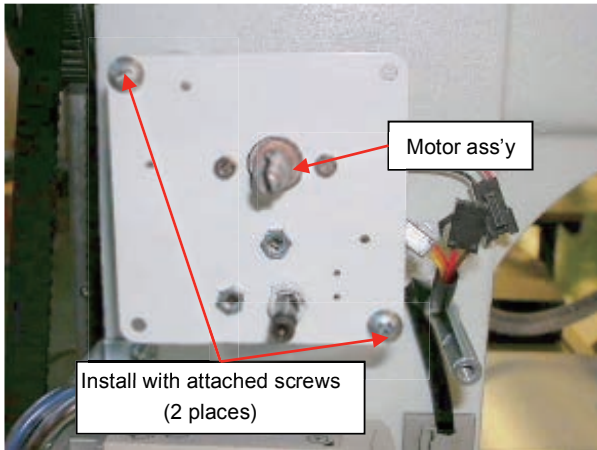

- * Make sure with mounting direction
- * Motor has to come upper position.

4. Connect DC motor relay cable from Arm body and 2P connector (Limit switch cable) from Bobbin thread winder assembly.

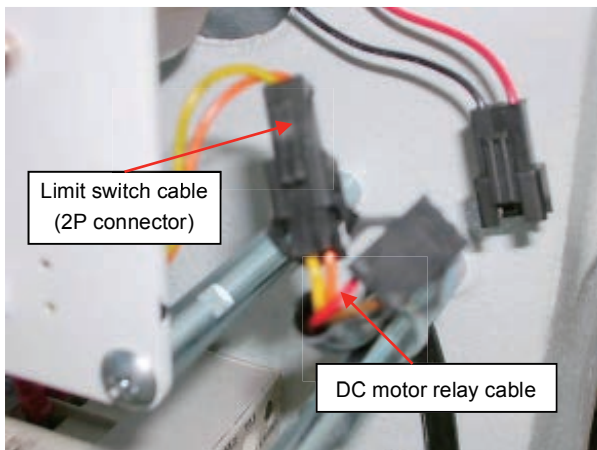

5. Connect 3P connector (DC motor relay cable) from Arm body and 3P connector (DC motor cable) from Bobbin thread winder assembly.

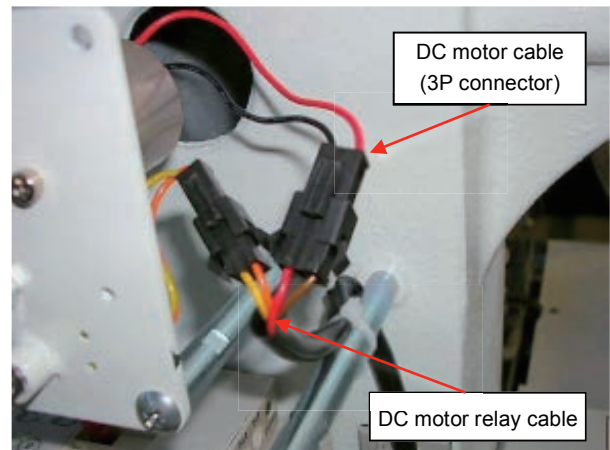

6. Remove Cover J from Cover B

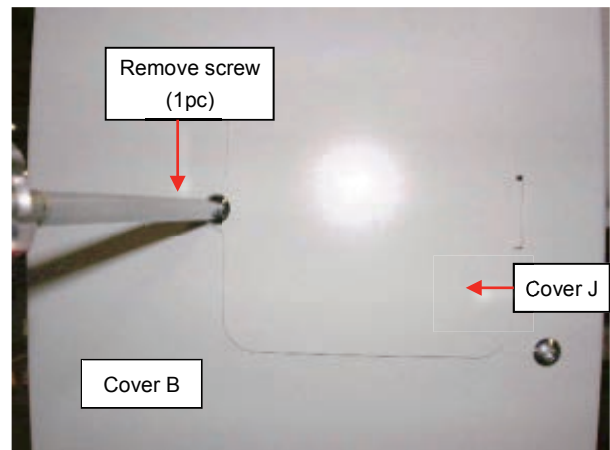

7. Install Cover B to Body.

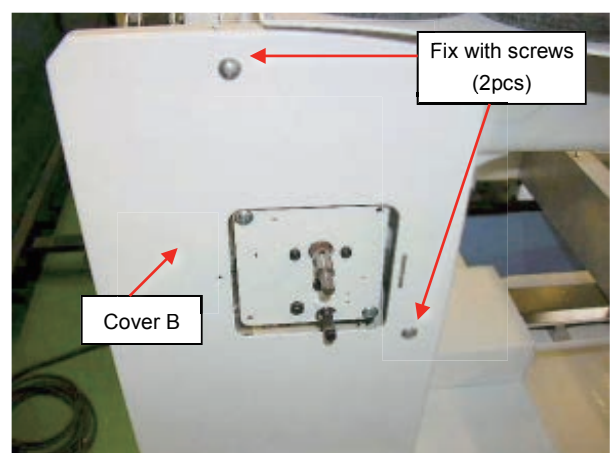

8. Install Cover B with screws.

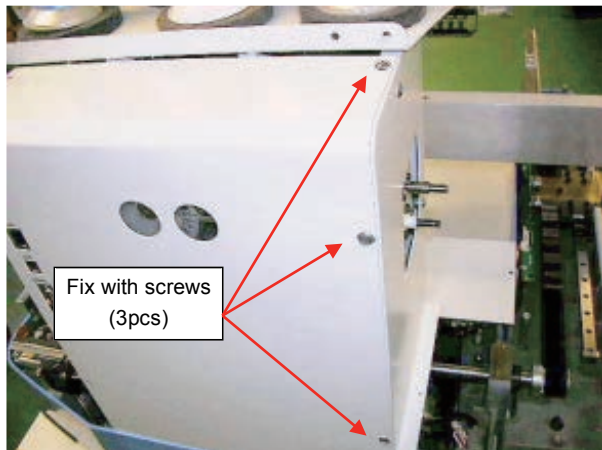

9. Remove screw from Cover D and Install Thread stand pin to Cover D.

Use Flat head screwdriver.

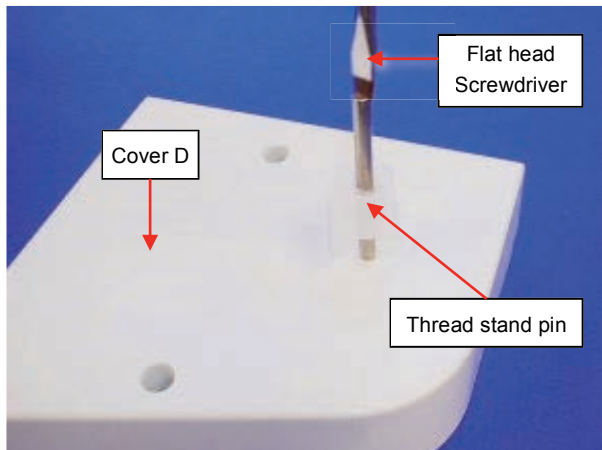

10. Install Cover D on to the Machine body.

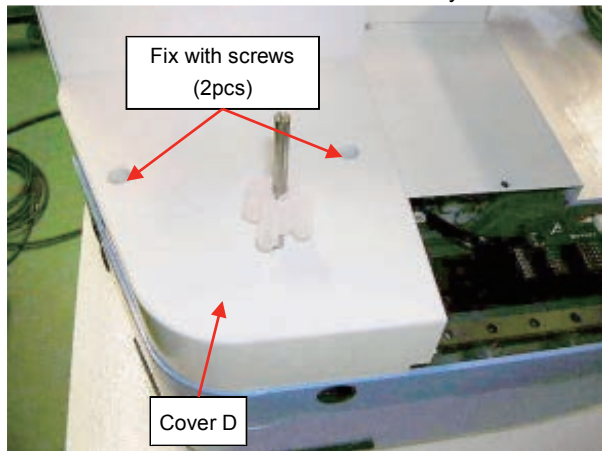

11. Install Bobbin thread tension assembly to Thread stand

as the picture below.

(Before installment)

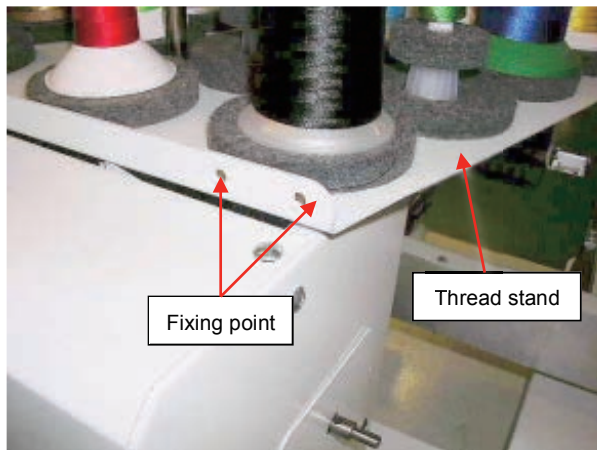

(After installment)

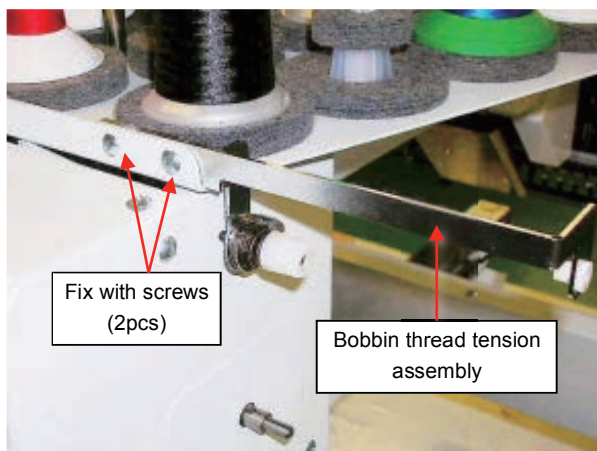

12. Reinstall Guide which has been removed at procedure 1.

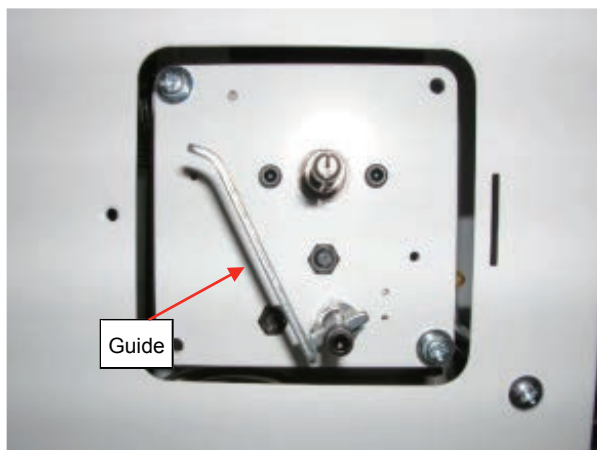

13. Adjust position of Guide.

Put Empty bobbin into Thread winding shaft and adjust position of Guide to be center of Empty bobbin.

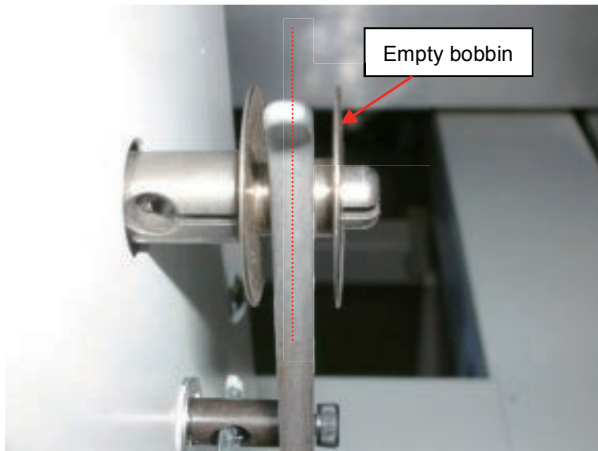

* Loosen screw(2pcs) of Thread winding shaft and adjust position by moving backward or forward.

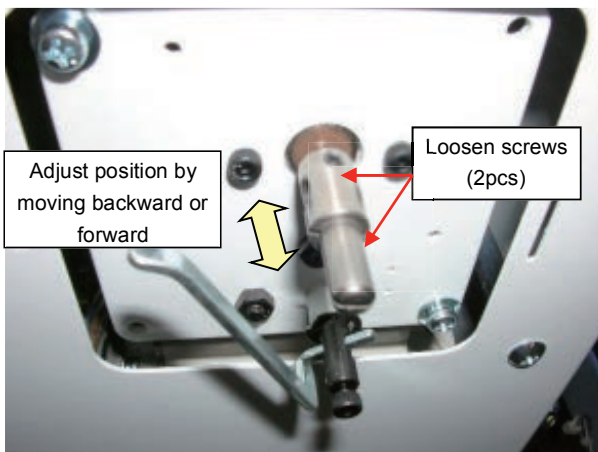

14. Wind the bobbin thread. Put the thread through as below.

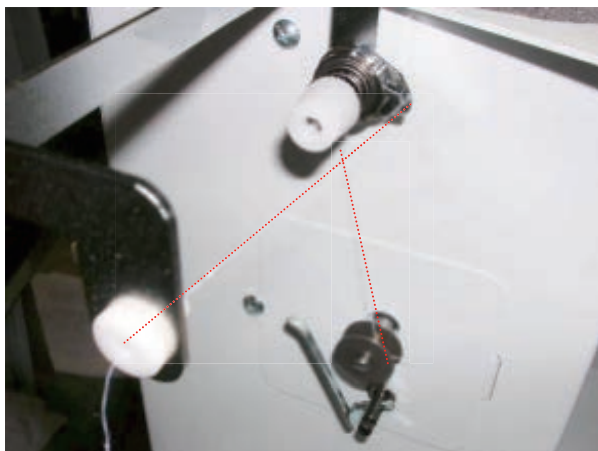

* Check thread winds up properly by adjusting position of procedure 13.

15. Remove Guide and install attached Winder cover to Cover B.

<Note> Clearance around shaft should be kept averagely.

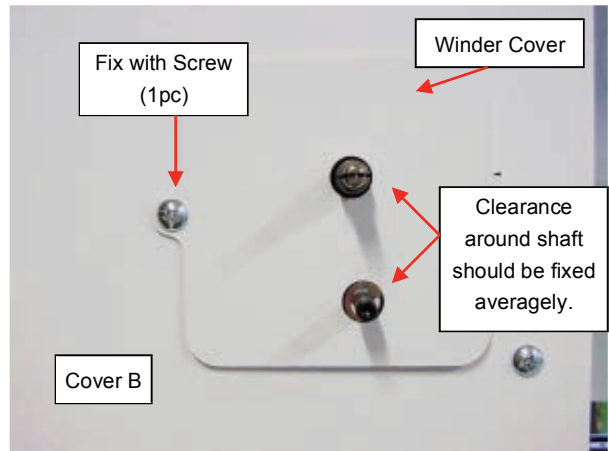

16. Install Guide which has been removed on procedure 15



17. Wind the bobbin thread.

Adjust Position of Guide to adjust volume of thread to be wound.

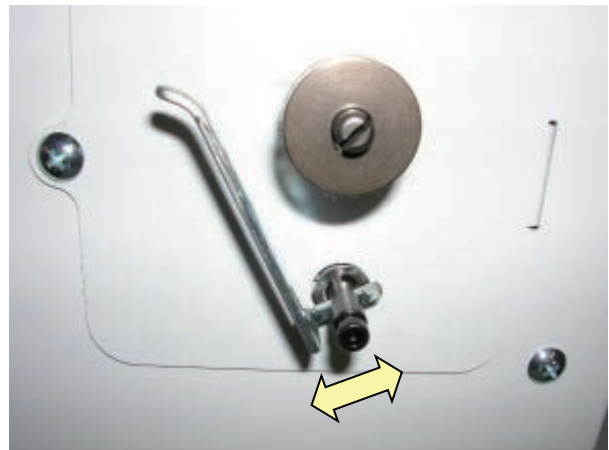

Installment of Bobbin thread winder is finished.

10-1 Electrical connection diagram (for LCD-CE board) 1/3

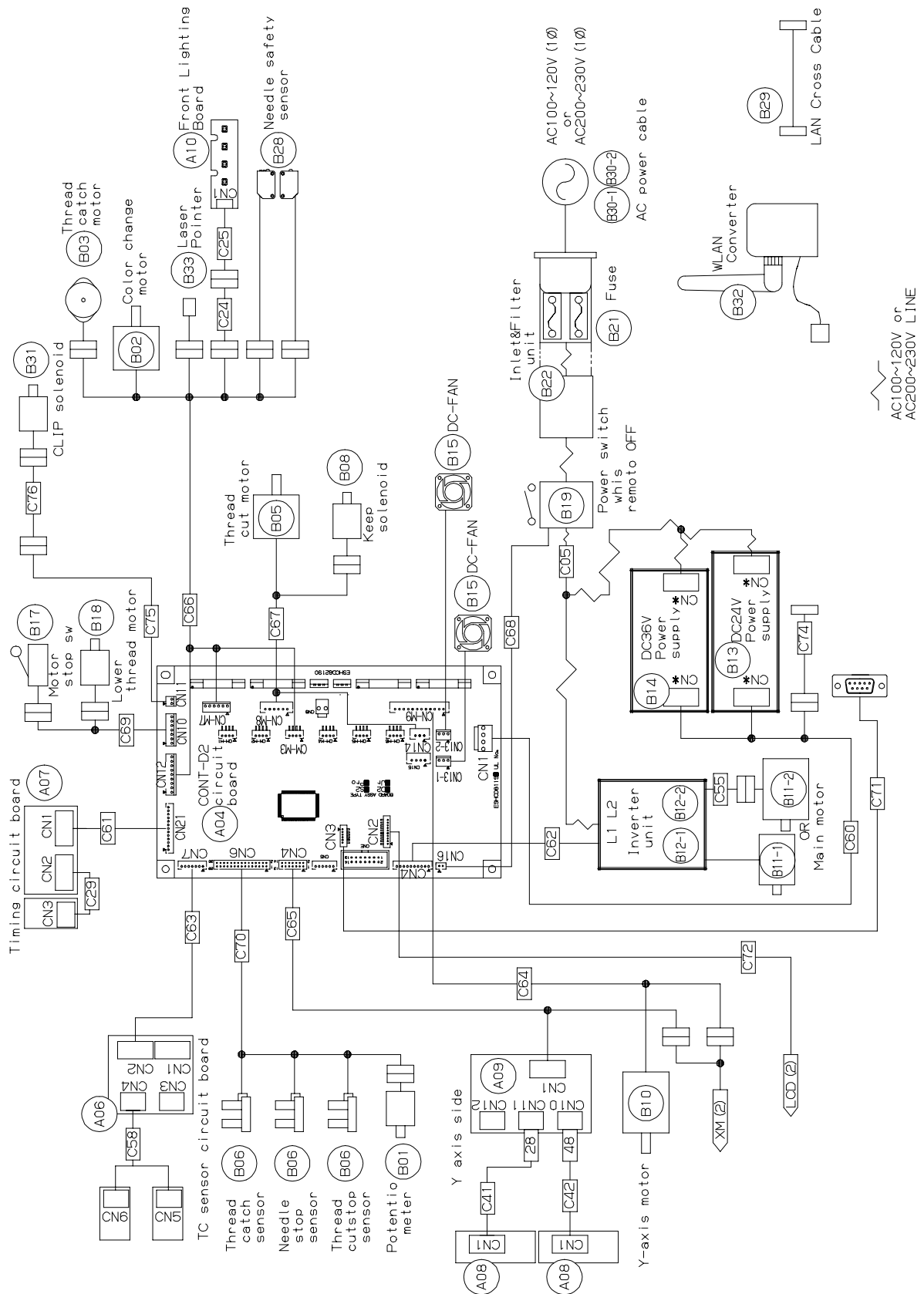

10-1 Electrical connection diagram (for LCD-CE board) 2/3

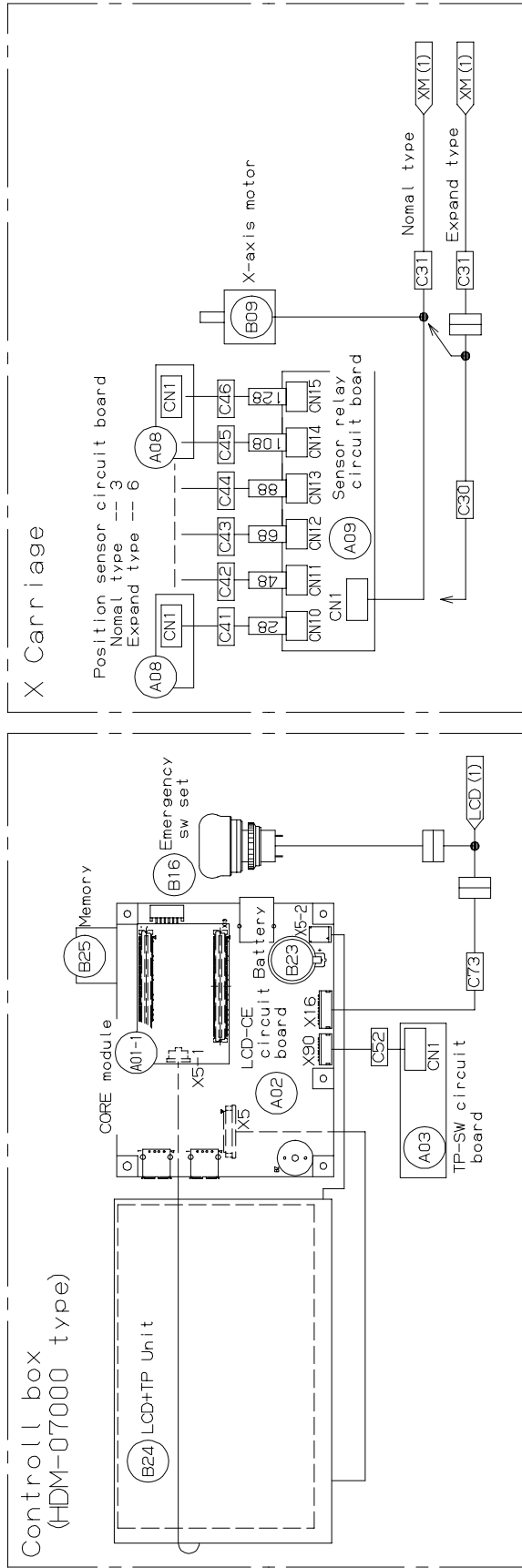

10-1 Electrical connection diagram (for LCD-CE board) 3/3

Parts Names	Parts No.	Input110V type inverter unit or Input230V type inverter unit	Limit relay cable2	ESHCD7243*	(OPTION)
A01-1 Core module	ESEPZ01118*	B12-1	C43	ESHCD7243*	
A02 LCD-CE circuit board	ESHCD8120*	B12-2	C52	ESHCD7252*	
A03 TP-SW circuit board	ESHCD8116*	B13	C58	ESHCD7258*	
A04 CONT-D2 circuit board	ESHCD8119*	B14	C60	ESHCD7260*	
A06 TC sensor circuit board	ESHCD8117*	B15	C61	ESHCD7261*	B28 Needle safety sensor
A07 Timing circuit board	ESHCD8109*	B16	C62	ESHCD7262*	B17 Lower thread stop switch
A08 Position sensor circuit board	ESHCD8110*	B19	C63	ESHCD7263*	B18 Lower Thread DC-motor unit
A09 Sensor Relay circuit board	ESHCD8111*	B21	C64	ESHCD7264*	B31 Clip solenoid
A10 Front lighting circuit board	ESHCD8116*	B22	C65	ESHCD7265*	B11-2 Main motor
		B23	C66	ESHCD7266*	B32 WLAN Converter
		B24	C67	ESHCD7267*	B33 Laser pointer
		B25	C68	ESHCD7268*	
		B29	C69	ESHCD7269*	
B01 Potentiometer	ESHCB7960*	B30-1	C70	ESHCD7270*	C30 X-motor relay cable
B02 Color change motor	ESHCD7911*	B30-2	C71	ESHCD7271*	C44 Limit relay cable (880)
B03 Thread catch motor	ESHCD7951*		C72	ESHCD7272*	C45 Limit relay cable (1080)
B05 Thread cut motor	ESHCB7920*		C73	ESHCD7273*	C46 Limit relay cable (1280)
B06 Photo sensor	ESEPP0052*		C74	ESHCD7274*	C55 MOTER cable
B08 Keep solenoid	ESHCD7939*		C75	ESHCD7275*	C76 CLIP cable2
B09 X-axis motor	ESHCD7912*				
B10 Y-axis motor	ESHCD7913*				
B11-1 Main motor 90W	ESHCB7931*				

Attention •Inverter
 •AC power cable Product varies in a power supply to use
 *mark is a revision number

10-2 Electrical connection diagram (for LCD-CE-U, LCD-CE-MX board) 1/4

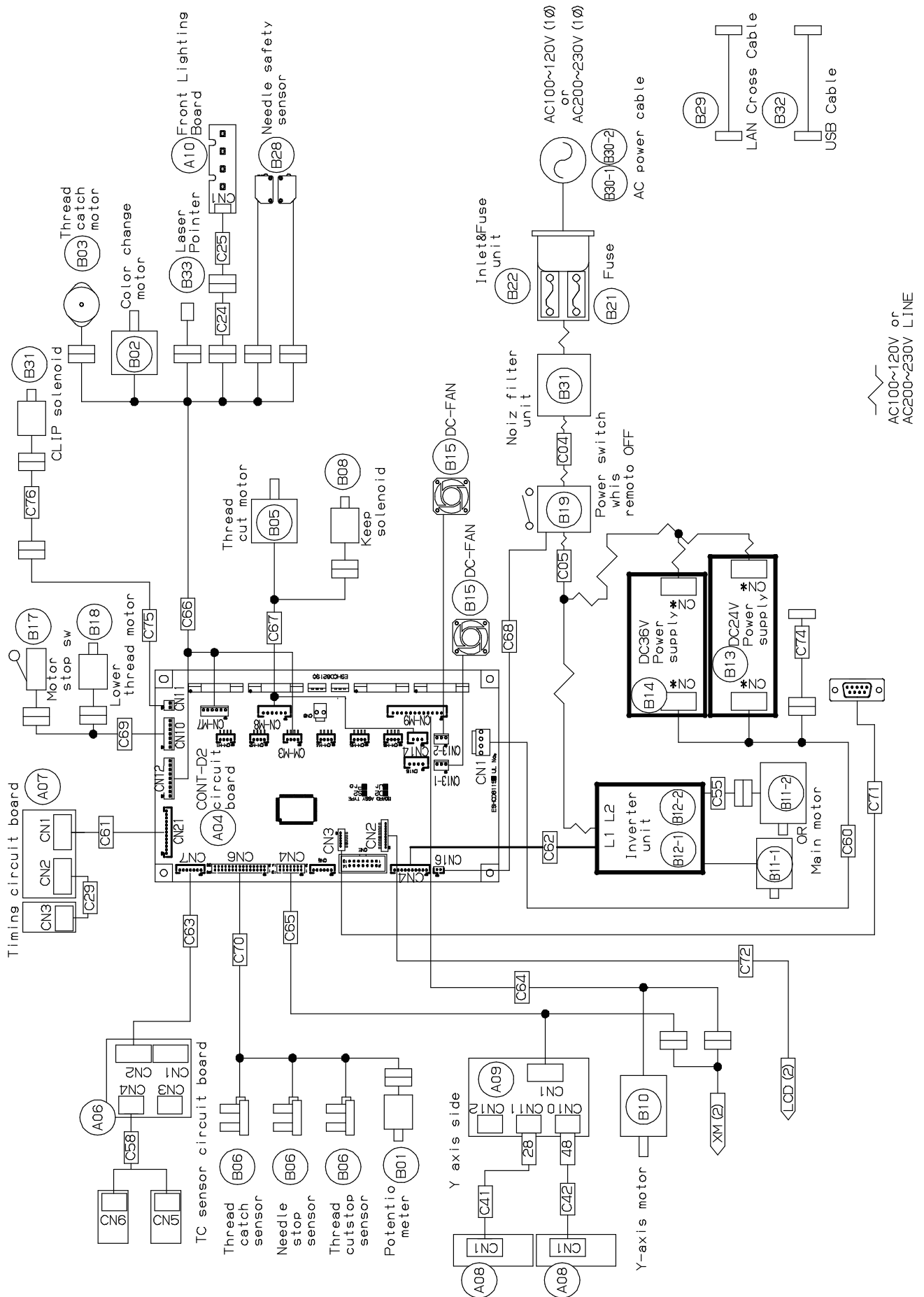

10-2 Electrical connection diagram (for LCD-CE-U, LCD-CE-MX board) 2/4

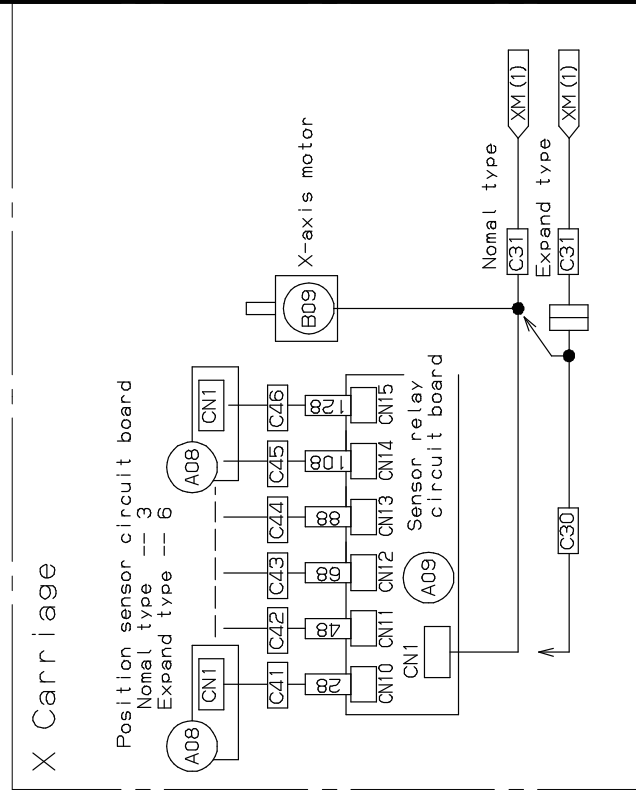
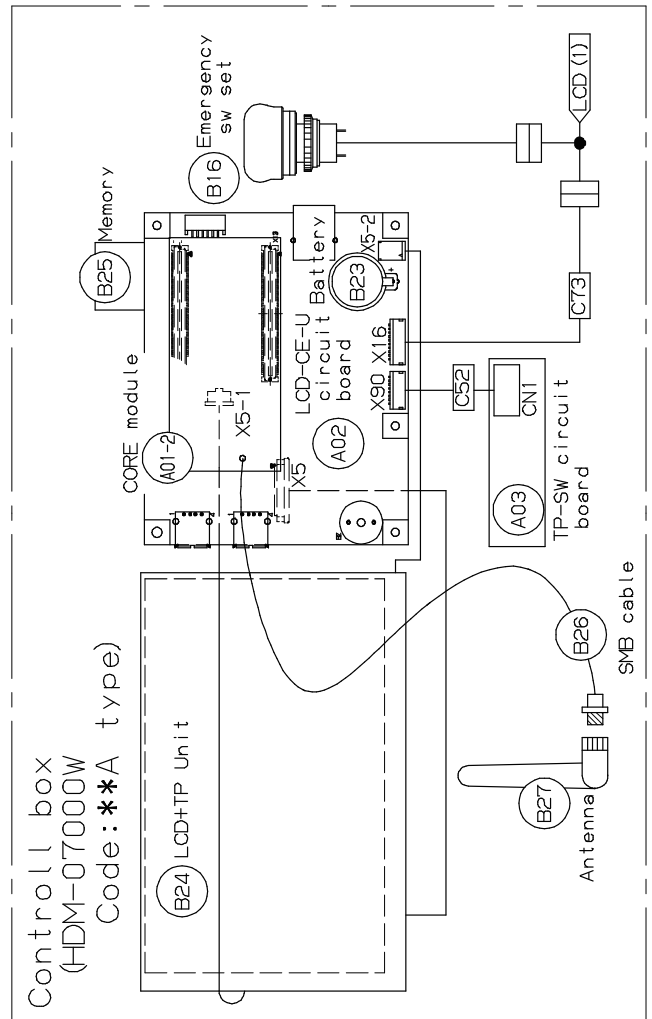
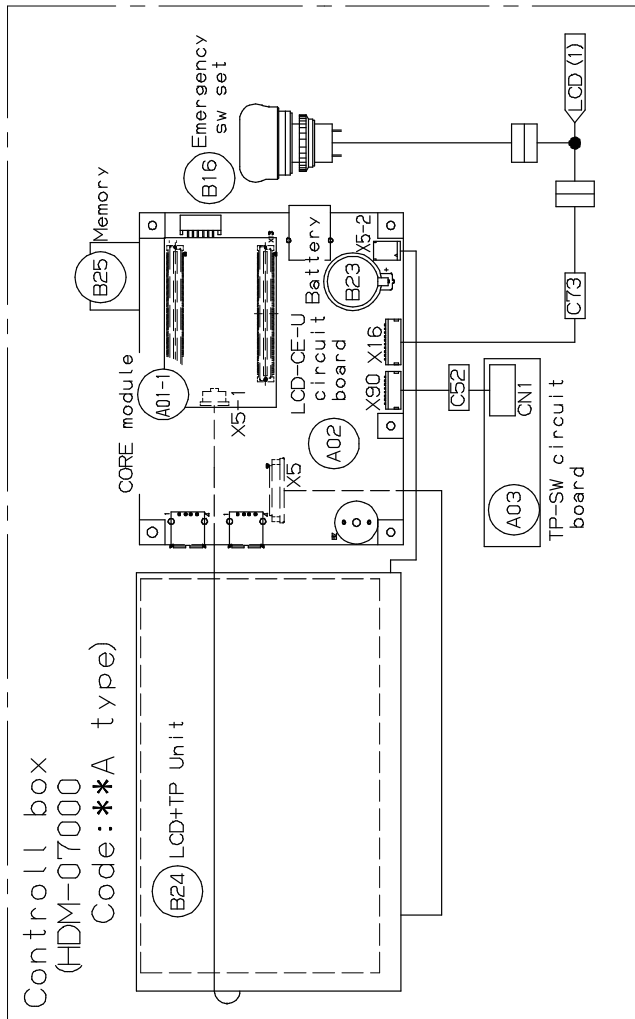

10-2 Electrical connection diagram (for LCD-CE-U, LCD-CE-MX board) 3/4

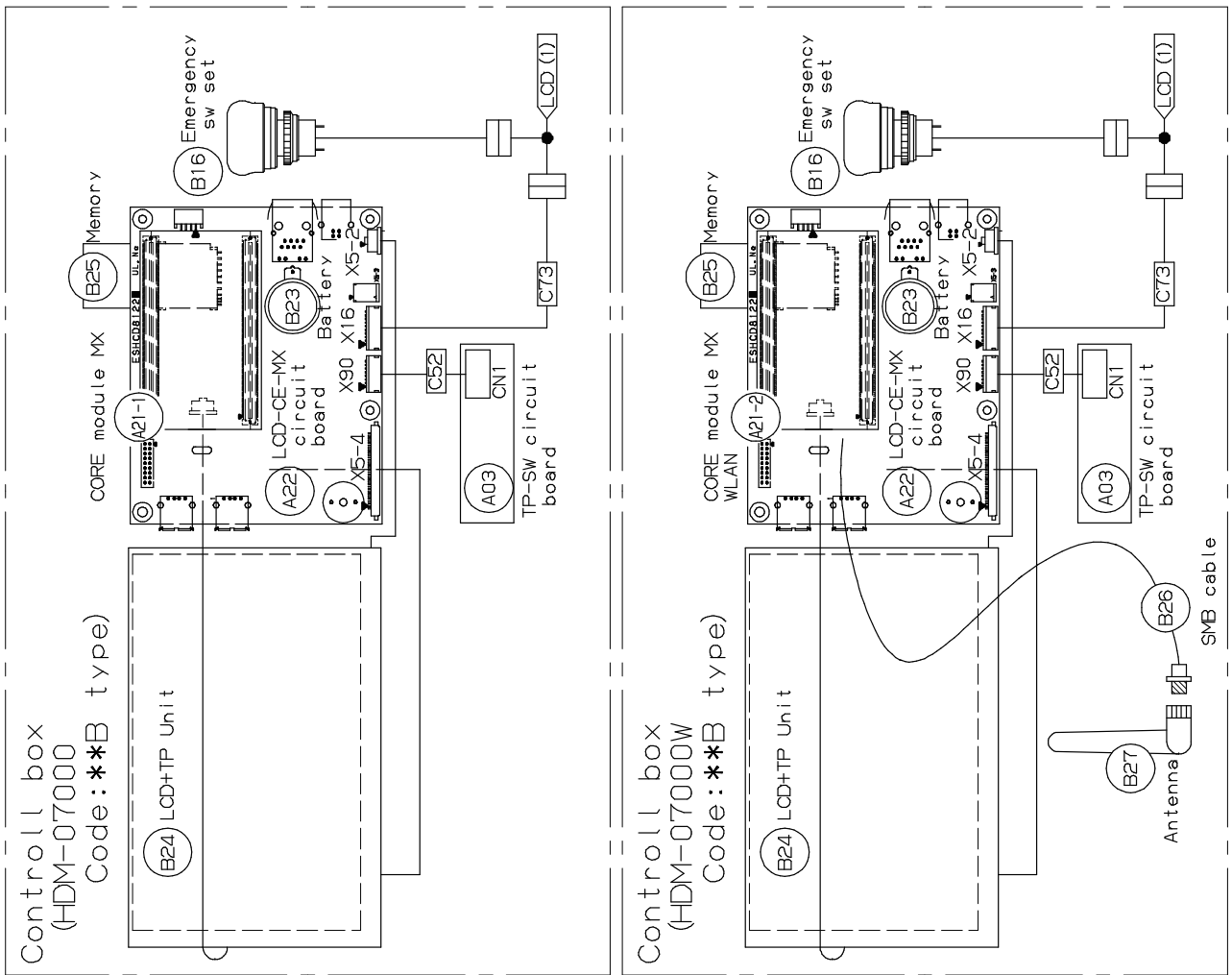

10-2 Electrical connection diagram (for LCD-CE-U, LCD-CE-MX board) 4/4

Parts Names	Parts No.	Power supply	EPK0093*	Limit relay cable2	HCD7243*	(OPTION)
(A01-1) Core module	EPZ0118*	(B13) DC24V	EPK0093*	(C43) Limit relay cable2	HCD7243*	(A01-2) Core module WLAN
(A21-1) Core module MX	EPZ0140*	(B14) DC36V	EPK0094*	(C52) SW cable2	HCD7252*	(B26) SMA cable
(A02) LCD-CE-U circuit board	HCD8121*	(B15) DC FAN unit	HCD7916*	(C58) TC sensor cable2	HCD7256*	(B27) Antenna
(A22) LCD-CE-MX circuit board	HCD8122*	(B16) Emergency sw set	HCD7945*	(C60) DC cable2	HCD7260*	(B28) Needle safety sensor
(A03) TP-SW circuit board	HCD8116*	(B19) Power switch remote off	EPS0089*	(C61) TMG cable2	HCD7261*	(B17) Lower thread stop switch
(A04) CONT-D2 circuit board	HCD8119*	(B21) Fuse (250V 6A)	EPF0036*	(C62) INV-S cable2	HCD7262*	(B18) Lower Thread DC-motor unit
(A06) TC sensor circuit board	HCD8117*	(B22) Inlet&fuse unit2	HCD7953*	(C63) TC relay cable2	HCD7263*	(B31) Clip solenoid
(A07) Timing circuit board	HCD8109*	(B23) Battery CR2032	EPZ0119*	(C64) MOTOR cable2	HCD7264*	(B11-2) Main motor 200W
(A08) Position sensor circuit board	HCD8110*	(B24) LCD+TP unit	HCD7954*	(C65) Sensor relay cable2	HCD7265*	(B33) Laser pointer
(A09) Sensor Relay circuit board	HCD8111*	(B25) Memory card	EPZ0122*	(C66) U-side cable2	HCD7266*	
(A10) Front lighting circuit board	HCB8116*	(B29) LAN cross cable	EPZ0126*	(C67) CUT&KEEPER cable2	HCD7267*	
(B01) Potentiometer	HCB7960*	(B30-1) AC power cable (110V) or (B30-2) AC power cable (220V)	EPRE0015* (UL type) EPRE0013* +PE0003* (PSE type)	(C68) PD cable2	HCD7268*	(A21-1) Core module MX
(B02) Color change motor	HCD7911*	(B31) Noiz Filuter	EPK0117*	(C69) UDC cable2	HCD7269*	(A21-2) Core module MX WLAN
(B03) Thread catch motor	HCD7951*	(B32) USB cable	EPZ0075*	(C70) Sensor cable2	HCD7270*	(A22) LCD-CE-MX circuit board
(B05) Thread cut motor	HCB7920*	(C04) Filuter cable2	HCD7204*	(C71) RS232C cable2	HCD7271*	
(B06) Photo sensor	EPF0052*	(C05) Power relay cable2	HCD7205*	(C72) CONT cable2	HCD7272*	
(B08) Keep solenoid	HCD7939*	(C24) Front led relay cable2	HCD7224*	(C73) BOX cable2	HCD7273*	(C30) X-motor relay cable
(B09) X-axis motor	HCD7912*	(C25) Front led cable2	HCD7225*	(C74) 24VOUT cable2	HCD7274*	(C44) Limit relay (880) cable
(B10) Y-axis motor	HCD7913*	(C29) Encoder relay cable2	HCD7229*	(C75) CLIP relay cable2	HCD7275*	(C45) Limit relay (1080) cable
(B11-1) Main motor 90W	HCB7931*	(C31) X-motor cable2	HCD7231*	(C46) Limit relay (1280) cable	HCD7046*	(C55) MOTER cable
(B12-1) Input110V type inverter unit or (B12-2) Input230V type inverter unit	HCD7925*	(C41) Limit relay (280) cable2	HCD7241*	(C47) CLIP relay cable2	HCD7045*	(C76) CLIP cable2
(B12-2) Inverter unit	HCD7927*	(C42) Limit relay (480) cable2	HCD7242*			

Attention •Inverter
•AC power cable Product varies in a power supply to use
*mark is a revision number

10-3 Connection of inverter

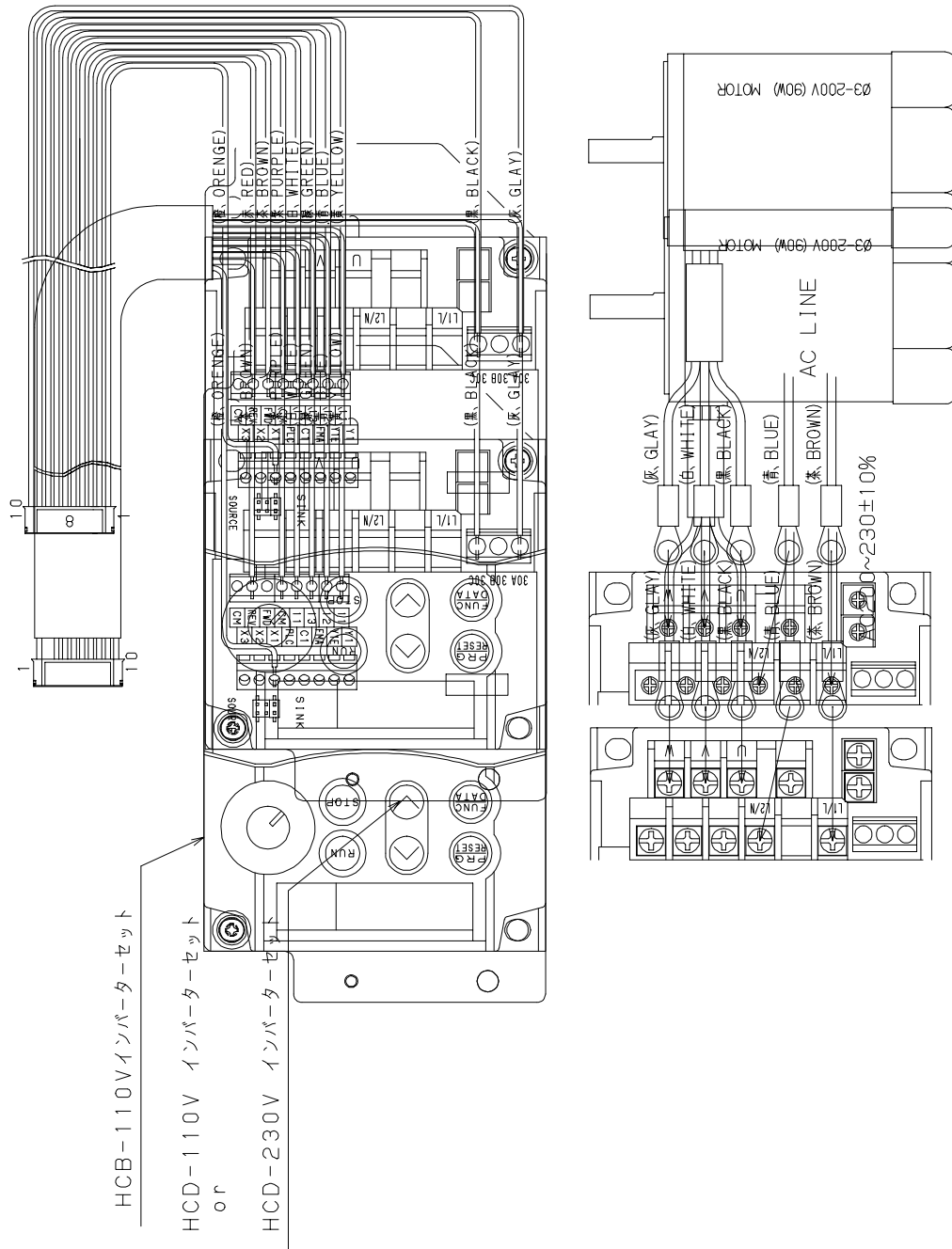

10-4 Explanation of function of circuit board

HCD8121*

LCD-CE-U Circuit Board Ass'y

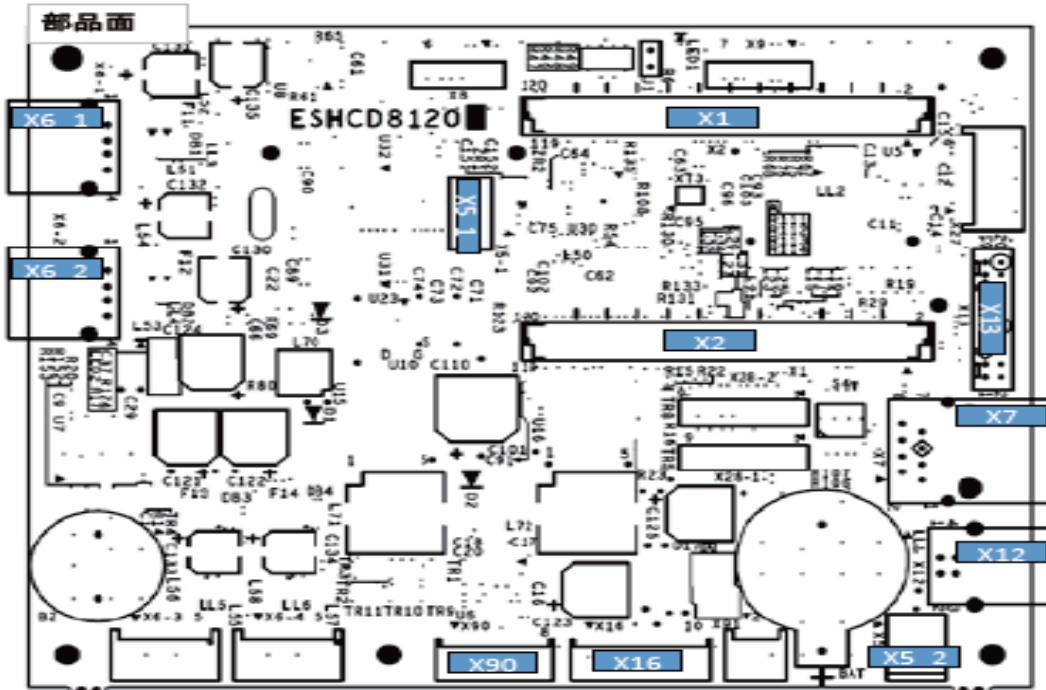

CN No.	Function
X1	Core module I/F
X2	Core module I/F
X5	7in LCD I/F
X5_1	7in touch panel input
X5_2	7in LCD backlight output
X6_1	USB-A connector 1
X6_2	USB-A connector 2
X7	LAN
X12	USB-B connector
X13	AUX
X14	SD card
X16	TP-SW board I/F
X90	CONT-** board I/F
Other CN	Reserved

HCD8122*

LCD-CE-MX Circuit Board Ass'y

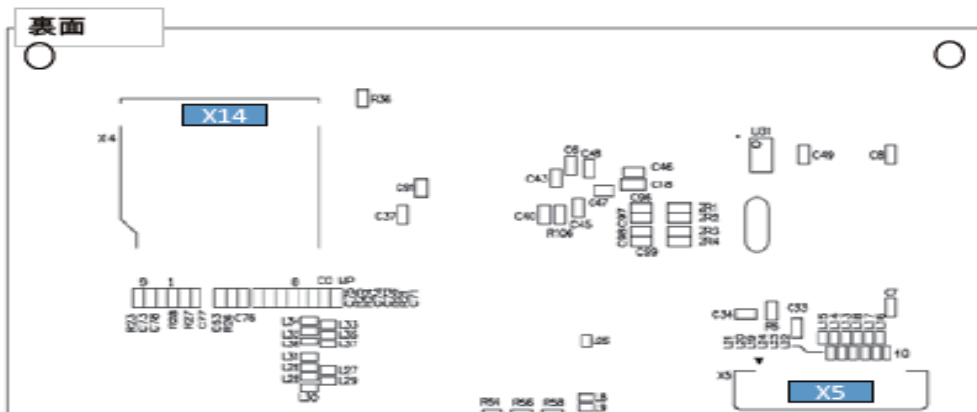
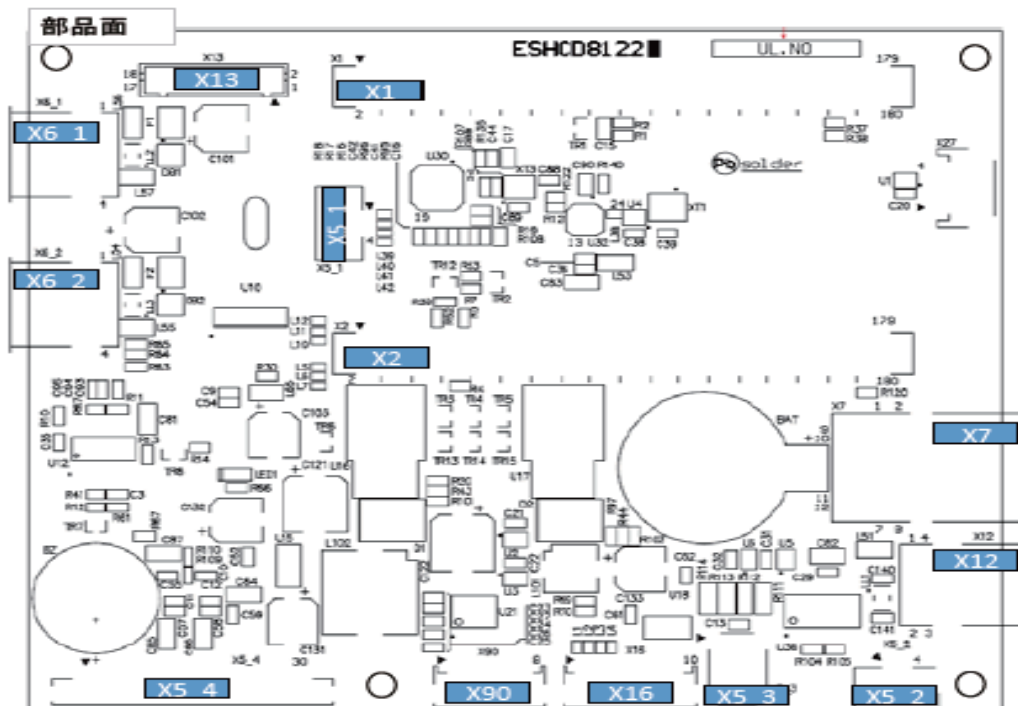

CN No.	Function
X1	Core module I/F
X2	Core module I/F
X5	7in LCD I/F
X5_1	7in touch panel input
X5_2	10.4in touch panel input
X5_3	7in LCD backlight output
X5_4	10.4in LCD I/F
X6_1	USB-A connector 1
X6_2	USB-A connector 2
X7	LAN
X12	USB-B connector
X13	AUX
X14	SD card
X16	TP-SW board I/F
X90	CONT-** board I/F
Otherther Other CN	Reserved

HCD8116*

TP-SW Circuit Board Ass'y

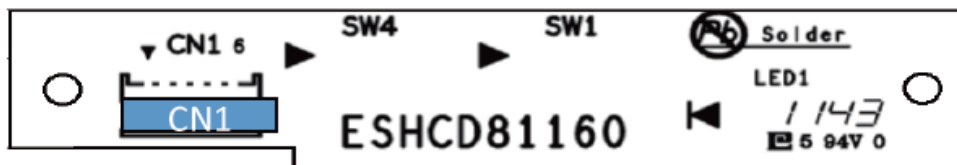

CN No.	Function
CN1	Switch output, LED input

HCD8119*

CONT-D2 Circuit Board Ass'y

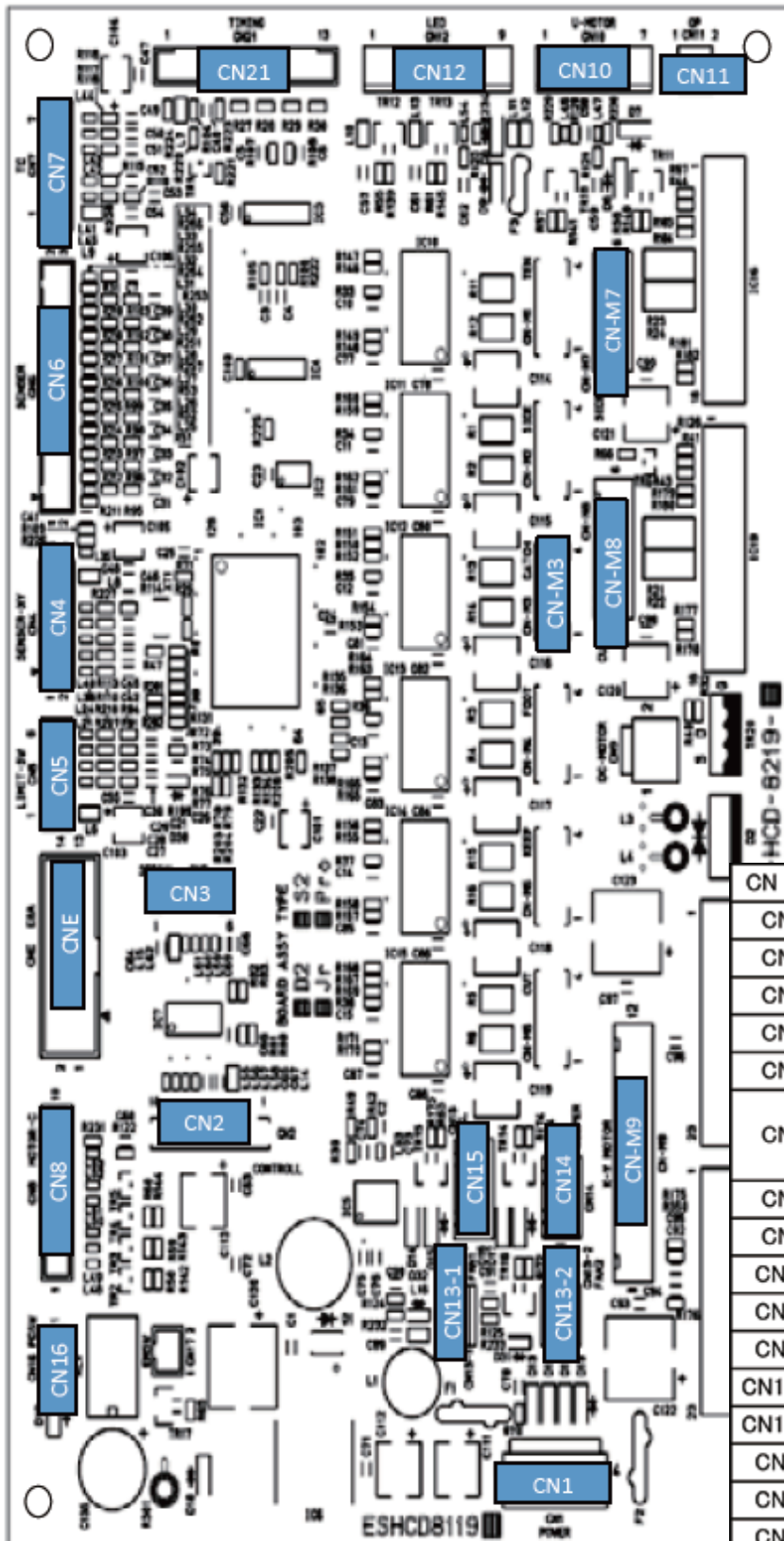

CN No.	
CN1	
CN2	Control box I/F
CN3	Option I/F
CN4	X position sensor I/F
CN5	Unused
CN6	Input of Thread catcher, Needle bar change, Thread cutting orig sensor Needle bar change potensionmeter
CN7	T/C sensor I/F
CN8	Inverter I/F
CN10	Bobbin winder motor output
CN11	Clip solenoid output
CN12	Laser pointer output, Front LED output
CN13-1	Fan 1 I/F
CN13-2	Fan 2 I/F
CN14	Keeper solenoid output
CN15	AUX
CN16	Main switch remote output
CN21	Input of C poiny, L point, Main shaft angle
CN-M3	Output of Thread catch motor
CN-M7	Needle bar change motor output
CN-M8	Thread cutting motor output
CN-M9	X-Y motor output
CNE	AUX

HCD8117*H

HCD8117*S

TC SENSER Circuit Board Ass'y

CN No.	Function
CN1	AUX
CN2	Sensor switching input, Sensor output
CN3	AUX
CN4	Sensor input
CN5	Sensor output
CN6	Sensor output

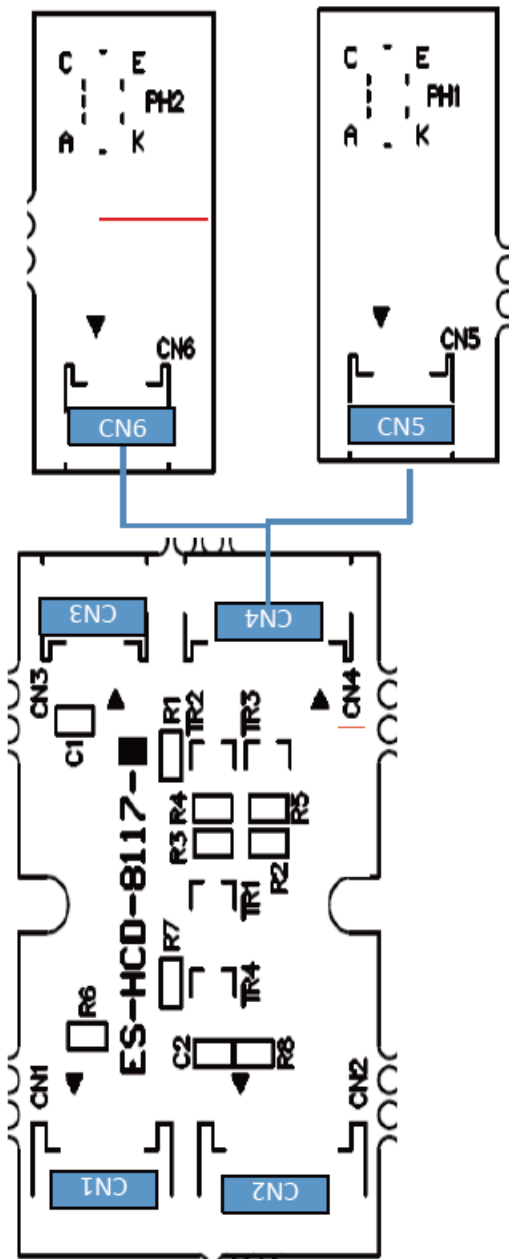

HCD8109*

TIMING Circuit Board Ass'y

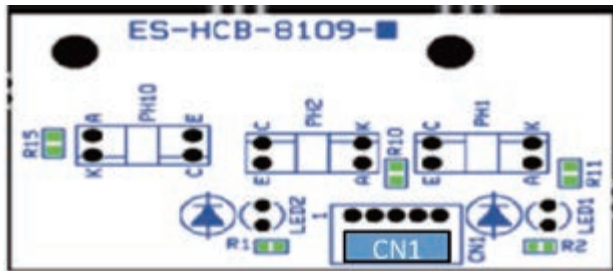

CN No.	Function
CN1	Out put of L point, C point, angle sensor

HCD8111*

Sensor relay board ass'y

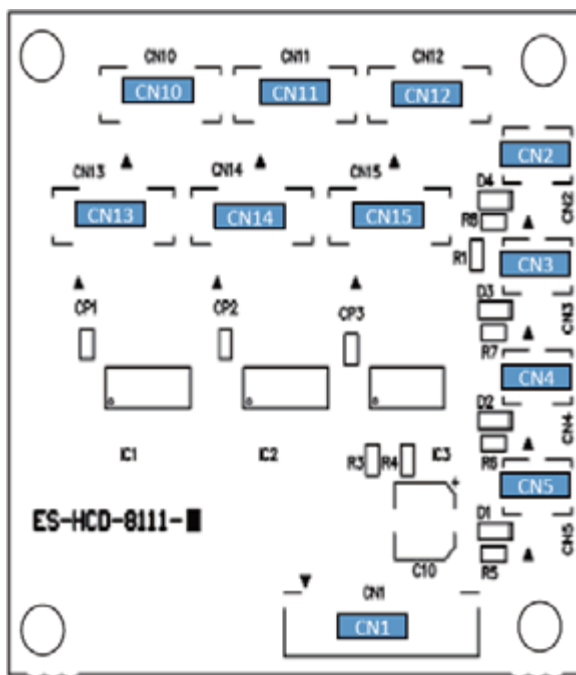

CN No.	Function
CN1	Switching sensor input, Output of present sensor
CN2	Input of switch 1
CN3	Input of switch 2
CN4	Input of switch 3
CN5	Input of switch 4
CN10	Input 1 of position sensor
CN11	Input 2 of position sensor
CN12	Input 3 of position sensor
CN13	Input 4 of position sensor
CN14	Input 5 of position sensor
CN15	Input 6 of position sensor

HCD8110*

POSITION SENSER Circuit Board Ass'y



CN No.	Function
CN1	Sensor out put

HCB8116*

FRONT LED Circuit Board Ass'y



CN No.	Function
CN1	24V power source input

11-1 How to respond for some question (As example step)

*When you receive some question from customer, please use this step for sold problem as sample.

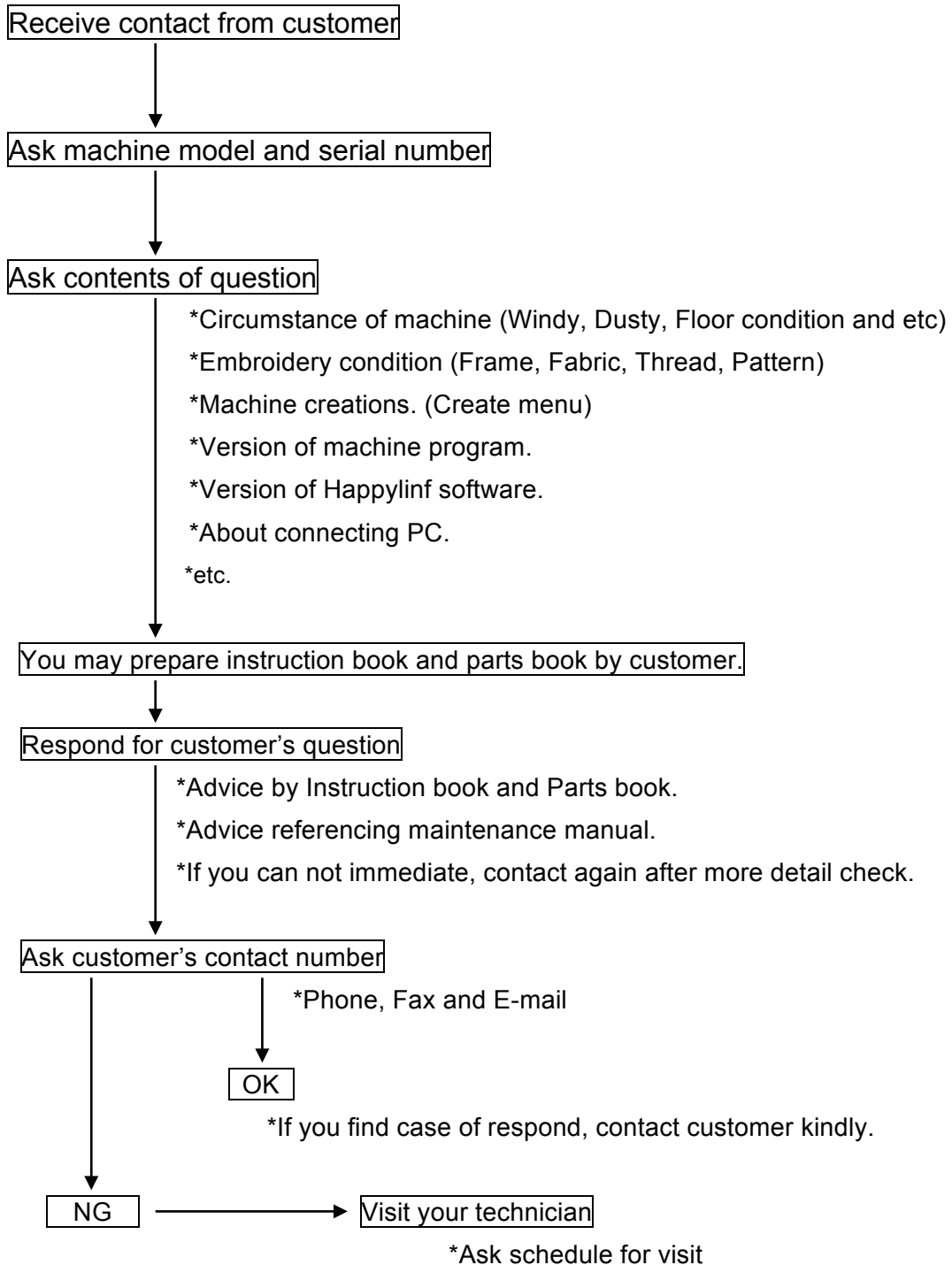

11-2-1 Trouble shooting (Electricity doesn't turn on)

Trouble	Factor	Cause of trouble and measure	Page
Electricity doesn't turn on	Mechanical	1. Did fuse blow? 1-1 If it did, replace it.	4-1
		2. Check of defect on board. 2-1 Replace of LCD-CE board. 2-2 Replace of LCD unit. 2-3 Replace of CONT-D2 board	5-2
		3. No problem in power supply? 3-1 Check and adjust the correct voltage. 3-2 Try to replace power supply.	4-3-2, 3 4-3-1
		4. Check Volume of the power failure detection fit with CONT-D2 board. 4-1 Adjust of power failure detection.	4-4-4
		5. Check of Cable catching causes short-circuit. 5-1 Please insulate the cable after removing outer cover. 5-2 Replace of cable.	
		6. Confirm not getting power supply from same outlet with other embroidery machine or other machines which contains motor. 6-1 Preferably only 1 embroidery machine should be connected with 1 outlet. (Maximum 2-3machines)	
	Operator	1. Didn't press emergency switch? 1-1 Release lock.	(3-8)
	Environment	1. Is electricity in receptacle? 1-1 Supply power.	

() ----- Reference instruction book

11-2-2 Trouble shooting (Thread break)

Trouble	Factor	Cause of trouble and measure	Page
Thread break	Mechanical	1. Is needle drop unstable by vibration? 1-1 Reconsider where to install the machine. 1-2 Move the machine to floor fully reinforced. 1-3 Use strong table to be able to endure vibration.	(2-2)
		2. No burr or scratch in thread guide hole? 2-1 Remove burr and scratch. 2-2 Replace of thread guide.	3-1-1
		3. No problem in thread adjusting spring? 3-1 Replace spring if it doesn't spring. 3-2 If weak or broken, replace it.	3-1-1
		4. Does detecting roller make smooth turn? 4-1 Clean inside hole of bearing. 4-2 Correct so as for slit disc not to touch sensor. 4-3 Correct so as for cable not to touch slit disc. 4-4 Check cable of TC 12 Board is unconnected	
		5. No problem in thread guide unit and thread tension ass'y? 5-1 Remove burr and scratch if appeared. 5-2 Remove lints and clean.	3-1-1
		6. Does disc on thread tension ass'y. turn smoothly? 6-1 Remove lints and clean. 6-2 Replace	3-1-1
		7. Is backlash between take-up lever and take-up crank roller not bigger? 7-1 Replace of take-up lever.	3-3-9
		8. No problem in needle holder? 8-1 Remove burr and scratch. 8-2 Make proper fixing. (direction) 8-3 Replace if thread guide is bent.	3-1-2 3-1-1
		9. No burr and scratch on needle plate? 9-1 Remove burr and scratch in needle hole. 9-2 Remove burr and scratch around needle hole on back of needle plate. 9-3 Replace it if not furbished. 9-4 If furbishing made needle hole wider, replace it.	3-1-1
		10. No problem in pressure foot? 10-1 Remove burr and scratch. 10-2 Correct bent. 10-3 Adjust height. 10-4 Replace of pressure foot. 10-5 Replace of pressure foot drive cam.	3-1-1 3-1-1 3-3-6 3-2-11 3-2-4

11-2-2 Trouble shooting (Thread break)

Trouble	Factor	Cause of trouble and measure	Page
Thread break	Mechanical	11. No problem in rotary hook? 11-1 Clean it to remove lints. 11-2 Furbish scratch. 11-3 If backlash of bobbin case holder and outer hook grows bigger, replace them. 11-4 Replace.	3-1-1
		12. No problem in rotary hook retainer? 12-1 Remove burr and scratch. 12-2 Adjust position.	3-5-2
		13. No problem in needle? 13-1 Fix it properly . 13-2 Select proper size of needle to match thread thickness. 13-3 If tip of needle is warped or bent, replace. 13-4 Replace.	3-1-2 3-1-4 3-1-1
		14. No problem in bobbin case? 14-1 Remove rust and scratch. 14-2 If thread guide spring is off, replace it.	
		15. No problem in bobbin? 15-1 Remove scratch (iron bobbin). 15-2 If distorted. replace it.	
		16. Is needle bar spring not broken? 16-1 Replace it.	3-3-7
		17. Does needle bar make smooth movement? 17-1 If bent, replace it.	3-3-7
		18. No backlash in moving head? 18-1 Adjust positioning roller shaft.	3-3-3
		19. Needle doesn't drop in the center of needle hole. 19-1 Adjust positioning plate and adjust needle drop back and forth. 19-2 Adjust position of needle selection unit, then adjust needle drop right and left.	3-3-3 3-4-1
		20. Is the lowest needle position proper? 20-1 Adjust mechanical lowest needle position. 20-2 Adjust electric lowest needle position.	3-2-5 3-8-3
		21. Is needle height proper? 21-1 Adjust as specified.	3-3-63
		22. Is rotary hook timing proper? 22-1 Adjust as specified.	3-5-1
		23. Is clearance between needle and rotary hook proper? 23-1 Adjust as specified.	3-5-1

() ----- Reference instruction book

11-2-2 Trouble shooting (Thread break)

Trouble	Factor	Cause of trouble and measure	Page
Thread break	Mechanical	24. Check tip of keeper hit the bobbin case. 24-1 Adjust it regularly.	3-6-8
		25. Is take-up lever timing proper ? 25-1 Adjust as specified.	3-2-9
		26. No problem in timing belt? 26-1 Adjust tension. 26-2 If scratched or damaged, replace it.	3-8-1 3-8-2
		27. Is revolution setting proper? 27-1 Make automatic speed setting.	7-4
		28. Is inverter setting proper ? 28-1 Make setting.	6-2
		Operator	1. Operation is wrong (no proper [Machine settings] setting for sewing?) 1-1 Tell how to operate.
		2. Is pattern dwindled too much by pattern adjustment? 2-1 Adjust size so as to produce less thread break. 2-2 Use pattern edited again (density_ change).	
		3. Is thread tension properly set? 3-1 <Upper thread> Considering sewing finish, set tension. 3-2 <Bobbin thread> Considering upper thread tension, set tension.	(8-1) (4-5)
		4. Is bobbin winding proper? 4-1 Adjusting bobbin winding tension, wind with proper strength.	(4-4)
		5. Is bobbin put in bobbin case properly? 5-1 Viewing from front of bobbin case, set so that bobbin turns left-wise.	(4-5)
		6. Does thread cone stand properly? 6-1 Keep thread from hitting felt. 6-2 Stand vertically.	(4-6)
		7. Is passing of thread proper? 7-1 Pass thread properly.	(4-6) (4-7)
		8. Is cloth properly stretched? 8-1 No loosening and no too much tightening. Even tension in depth and width. 8-2 Texture should be even in direction of X and Y.	(6-2) (7-5)
		9. Is frame properly set? 9-1 Frame should be put in positioning hole on tubular-frame. 9-2 No loosening of screw.	(6-3) (7-6)

() ----- Reference instruction book

11-2-2 Trouble shooting (Thread break)

Trouble	Factor	Cause of trouble and measure	Page
Thread break	Operator	10. Is frame used to suit pattern size? 10-1 Use frame to suit pattern size.	(20-1)
		11. When you dispose of thread (thread remains around rotary hook), didn't you damage rotary hook, needle plate with scissors? 11-1 Tell to dispose of thread carefully. 11-2 Open needle plate to dispose of thread.	(23-3)
		12. Didn't you neglect cleaning and oiling? 12-1 Tell to always clean and use cleanly. 12-2 Tell to oil regularly.	(23-2)
	Thread & cloth	1. Is thread used to suit needle size? 1-1 Use thread to suit needle size.	3-1-4
		2. Is thread used to suit embroidery? (thread twist, tender thread). 2-1 Don't use too strongly twisted thread. 2-2 Twist of thread is to be left-wise. 2-3 Use tender thread. 2-4 Don't use thread with knot or uneven size.	3-1-3
		3. Is thread properly wound against cone? 3-1 Use thread to be wound smoothly.	
		4. Isn't tip of cone warped or isn't thread caught in scratch? 4-1 Remove warp and scratch.	
		5. Don't use thread left for a long period? (inferior thread). 5-1 Don't buy thread more than you use. 5-2 Tell not to store thread for a long period. 5-3 Tell how to store. (direct sunshine. humidity dust etc.)	
		6. Isn't poor unwoven cloth used? Is number of sheets used proper?	
	Environment	1. Is strength of table and floor enough? 1-1 Reconsider place to install the machine. 1-2 Move the machine to place where floor is strong enough. 1-3 Use table with strength endurable against vibration.	(2-2)
		2. Are room temperature and humidity proper against thread? 2-1 It is desirable to install air conditioner to keep temperature and humidity in a certain level.	(23-1)
		3. Doesn't embroidery machine receive direct sunlight? (cause of inferior thread) 3-1 See not to expose to sunlight (spread curtain)	

() ----- Reference instruction book

11-2-2 Trouble shooting (Thread break)

Trouble	Factor	Cause of trouble and measure	Page
Thread break	Environment	4. Is there something that produce steam, wasted cotton, dust around. the embroidery machine? 5-1 Keep the embroidery machine off those things.	
		5. Does thread go out of control by taking wind from outside or heater etc.? 6-1 Keep the embroidery machine off such wind. 6-2 Move the embroidery machine to proper place.	
	Pattern	1. Does thread break occur repeatedly at same place in design? 1-1 Check pattern to modify punching.	
		2. Is it too narrow between stitches? 2-1 Check pattern to modify punching. 2-2 Setting of [Reading] menu. (Stitch sweeper)	(14-4)
		3. Too many empty stitches? 3-1 Make [Reading] setting. (Skip null stitches)	(14-4)
	Others	1. Using spray paste (adhesive material) 1-1 Clean around rotary hook. 1-2 Replace or clean needle. 1-3 Use this paste at a given place and never use in front or back of the embroidery machine.	(23-2) 3-1-2

() ----- Reference instruction book

11-2-3 Trouble shooting (Erroneous thread cut)

Trouble	Factor	Cause of trouble and measure	Page
Erroneous thread cut (E-190) (E-193)	Mechanical	1. Is thread cut timing proper? 1-1 Set timing to specified value.	3-6-1
		2. Isn't rubbing of fixed knife and moving knife weak? 2-1 Adjust to be able to rub properly.	3-6-4
		3. Does moving knife make smooth move? 3-1 Check if rubbing of moving knife and fixed knife is not too strong. 3-2 Check no loosening of screw on moving knife. 3-3 Check no damage or scratch on face of moving knife.	3-6-4 3-6-2
		4. Check Displace of moving knife. 4-1 Adjust of moving knife position.	3-6-5
		5. Check defacement of moving knife or fixed knife. 5-1 If possible, furnish with file. 5-2 Replace	3-6-4 3-6-2
		6. No backlash in up and down direction of knife drive shaft? 6-1 Check no loosening of screw on moving knife. 6-2 Check no loosening of screw on knife drive shaft.	3-6-2
		7. No backlash in fixed knife? 7-1 Check no loosening of screw on fixed knife.	3-6-4
		8. Does thread cut pulse motor work properly? 8-1 Check cable. 8-2 If trouble found in LCD-CE board or CONT-D2 board, replace. 8-3 If trouble found in thread cut pulse motor, replace. 8-4 Adjust of thread cut sensor position.	4-2 3-6-1
		9. Is number of revolution proper at time of thread cut? 9-1 Make automatic speed setting. 9-2 If trouble in LCD-CE board or CONT-D2 board, replace.	7-4 5-2, 4-3
		10. Is there no skipped stitch? 10-1 Adjust needle depth. 10-2 Adjust clearance between needle and rotary hook. 10-3 Is height of pressure foot proper? 10-4 Is rotary hook timing proper? 10-5 Is relation between needle and thread proper?	3-3-6 3-5-1 3-2-10 3-5-1 3-1-4

() ----- Reference instruction book

11-2-3 Trouble shooting (Erroneous thread cut)

Trouble	Factor	Cause of trouble and measure	Page
Erroneous thread cut (E-190) (E-193)	Mechanical	11. Check the needle bar moves up and down during thread cut. 11-1 Adjust position of jump device. 11-2 Replace needle bar cushion. 11-3 Replace needle bar driver.	3-2-7 3-3-7 3-2-6
		12. Is position of keeper proper? 12-1 Adjust the fixed position regularly.	3-6-8
		13. Check the movement of keeper goes smoothly. 13-1 Readjust if it is not smooth.	3-6-7
	Operator	1. No negligence in cleaning thread cut device? 1-1 Tell to clean regularly. # It's desirable to prepare brush with soft hair and air gun.	(23-2)
		2. Is timing of thread tension proper? 2-1 <Upper thread> Considering sewing finish, set tension. 2-2 <Bobbin thread> Considering upper thread tension, set tension.	(8-1) (4-5)
	Environment	1. Are power and voltage rated and stable? 1-1 Supply rated voltage.	(23-1)
	Thread & cloth	1. Is twist of thread too strong? 1-1 Use thread with proper twist.	3-1-3
		2. No skipping by use of lots of paste? 2-1 Use small amount of paste. 2-2 Remove paste stuck to needle.	

() ----- Reference instruction book

11-2-4 Trouble shooting (Off-registration of pattern)

Trouble	Factor	Cause of trouble and measure	Page
Off-registration of pattern	Mechanical	1. Does frame move smoothly? 1-1 Avoid curling of thread and cloth. 1-2 Reinstall of outer cover in case of touch with outer cover.	2-2
		2. Is carriage belt tension proper? 2-1 Adjust all belts as specified.	3-7-1 3-7-3
		3. No loosening of screws on carriage drive? 3-1 Check screw. If loosened, tighten firmly.	
		4. No lints or dust around idler pulley on carriage? 4-1 Clean	
		5. No damage in carriage belt? 5-1 If damaged, replace.	3-7-2 3-7-4
		6. No backlash of back and forth in moving head? 6-1 Adjust positioning roller shaft to remove backlash back and forth.	3-3-3
		7. Is height of pressure foot proper? 7-1 Adjust as specified.	3-2-10
		8. No problem in motion of pulse motor? 8-1 Check wiring. If screw got loosened, tighten more. 8-2 After 9-1, still problem, then replace.	
		9. No problem in motion of CONT-D2 board ? 9-1 Check wiring. If screw got loosened, tighten more. 9-2 After 10-1, still problem, then replace.	4-2
		10. Doesn't other frame than Happy's genuine one used? 10-1 If frame is too heavy, don't use it. 10-2 If setting is not proper, set it so as not to move.	
		11. No problem in CONT-D2 board? 11-1 Try to initialize. 11-2 Replace of CONT-D2 board.	7-4
		12. Is number of revolution proper? 12-1 Make automatic speed setting.	7-4
		13. Not affected by noise? 13-1 Don't use the machine near where noise is generated.	

() ----- Reference instruction book

11-2-4 Trouble shooting (Off-registration of pattern)

Trouble	Factor	Cause of trouble and measure	Page
Off-registration of pattern	Mechanical	<p>14. No problem in timing sensor unit?</p> <p>14-1 Test the Machine-Machine movement #11 (Test of timing sensor unit) of Maintenance mode, Check timing sensor unit.</p> <p>If trouble found, error number and messages will be displayed.</p> <p>If measure doesn't solve the trouble, replace of timing circuit board or cable.</p>	<p>8-2</p> <p>3-8-3</p>
		<p>E-18 Problem in detecting angle of main shaft.</p> <p>Check timing slit.</p> <p>Adjust timing slit.</p> <p>Turn main shaft once by hand.</p> <p>If LED4 (L point) lights two times or more, Adjust detecting slit.</p>	3-8-4
		<p>E-51 L point sensor doesn't detect.</p> <p>E-52 C point sensor doesn't detect.</p> <p>Clean dust attached to sensor.</p> <p>Check detecting slit.</p> <p>If trouble found, Adjust detecting slit.</p>	3-8-4
	Operator	<p>1. Is setting of frame correct?</p> <p>1-1 Frame should be put in positioning hole on tubular frame.</p> <p>1-2 Set so as for screw not to loosen.</p>	(6-3) (7-6)

() ----- Reference instruction book

11-2-4 Trouble shooting (Off-registration of pattern)

Trouble	Factor	Cause of trouble and measure	Page
Off-registration of pattern	Operator	2. Is cloth properly stretched. 2-1 Stretch properly.	(6-2) (7-5)
		3. Is thread tension proper? 3-1 Observing sewing rhythm, set thread tension properly.	(4-5) (8-1)
		4. Was the machine left for a long time in middle of sewing? 4-1 Try to finish sewing as soon as possible.	
		1. Is strength of table and floor enough? 1-1 Check where to place the machine again. 1-2 Move to where floor is strong enough. 1-3 Use strong table to be able to endure vibration.	(2-2)
	Environment	2. No problem in pulse motor driver by low power and voltage (variation)? 2-1 Supply rated voltage. 2-2 Use transformer. 2-3 Use stabilizer.	(23-1)
		3. Is there no place where noise is generated near the machine? 3-1 Don't use the machine near where noise is generated.	
		4. Doesn't drive frame hit obstacle? 4-1 Remove obstacle. 4-2 When using cap frame, see not to hit table.	(7-2)
		1. Not using shrinkable cloth? 1-1 Use backing paper (consider number of sheets to use).	(4-3)
	Thread & cloth	2. Isn't breakable cloth is used by thread tightening? 2-1 Use backing paper (consider number of sheets to use).	(4-3)
		3. Is proper backing paper used? 3-1 Use backing paper to match cloth.	(4-3)
		4. Isn't cloth (embroidery) too heavy? 4-1 Don't use extremely heavy cloth.	
		Pattern	1. Pattern data may be destroyed. 1-1 Read again. 1-2 Let new pattern read.
	2. Memory pattern was destroyed. 2-1 Let new pattern read.		(5-6)
	3. No problem in floppy disc or memory card? 3-1 Initialize and read again. 3-2 Prepare new floppy disc or memory card.		(5-5)

() ----- Reference instruction book

11-2-5 Trouble shooting (Upper thread comes off from needle hole)

Trouble	Factor	Cause of trouble and measure	Page
Upper thread comes off from needle hole	Mechanical	1. Is keeper in motion? 1-1 Check if cable was cut or there is something unusual. 1-2 In case solenoid is in trouble, replace. 1-3 In case LCD-CE board is in trouble, replace. 1-4 In case CONT-D2 board is in trouble, replace.	3-6-7 4-2
		2. Is keeper put in right place? 2-1 Put it as specified. 2-2 Modify bent of keeper. 2-3 Adjust it again if movement is not smooth.	3-6-9 3-6-7
		3. When thread trim action, please check upper thread wind keeper or not. 3-1 If dose not wind, please adjust keeper position again	3-6-8.
		4. Is magic-tape on thread catch holder not worn? 4-1 Replace magic-tape.	3-3-11
		5. Does bobbin thread holder hold bobbin thread? 5-1 Adjust pressure when contacting moving knife. 5-2 In case bobbin thread holder is in trouble, replace. 5-3 Clean bobbin thread holder.	3-6-6
		6. No error in thread cut (2 threads cut)? 6-1 Check and adjust thread cut timing. 6-2 Position moving knife as specified. 6-3 Check and polish burr or scratch on moving knife. 6-4 In case moving knife is in trouble, replace.	3-6-1 3-6-5 3-6-2
		7. Are clearance between needle and rotary point and needle height are proper? 7-1 Adjust clearance between needle and rotary hook as specified. 7-2 Adjust needle depth.	3-5-1 3-3-6
		8. Doesn't thread catch hook cut upper thread? 8-1 Polish burr on hook. 8-2 In case hook is in trouble, replace.	
		9. Does thread catch hook hold upper thread? 9-1 Check if cable was cut or there is something unusual. 9-2 In case pulse motor is in trouble, replace. 9-3 Adjust fixing position. 9-4 If hook is bent, modify. 9-5 In case hook is in trouble, replace. 9-6 In case LCD-CE board is in trouble, replace. 9-7 In case CONT-D2 board is in trouble, replace.	3-2-12 4-2

() ----- Reference instruction book

11-2-5 Trouble shooting (Upper thread comes off from needle hole)

Trouble	Factor	Cause of trouble and measure	Page
Upper thread comes off from needle hole	Mechanical	10. Check the needle bar moves when start sewing. 12-1 Adjust position to fix jump device. 12-2 Replace needle bar driver.	3-2-5 3-2-4
		11. Is number of revolution proper when sewing started? 13-1 Make automatic speed setting.	7-4
		12. Is height of pressure foot proper? 14-1 Adjust as specified.	3-2-9
		Operator	1. Isn't thread tension too strong? 1-1 Weaken tension not to cause trouble in sewing rhythm.
		2. Keen in cleaning thread cut device? 2-1 Clean bobbin thread holder regularly.	(23-2)
		3. Is setting of bobbin thread proper? 3-1 Pass thread on bobbin thread guide surely.	(4-5)
		4. Is bobbin thread properly wound? 4-1 Adjust tensile strength of bobbin winder and check holding plate. 4-2 Pull out bobbin thread to check if it comes out smoothly.	(4-4) (4-5)
		5. Is upper thread properly passed? 5-1 Pass properly again.	(4-6) (4-7)
		6. Does thread cone stand properly? 6-1 Keep thread from hitting felt. 6-2 Stand vertically.	(4-6)
		7. Is [Machine settings] properly set? 7-1 Select setting of length of TRD. Cut [Long]. 7-2 Select setting of Quick start mode [No]. 7-3 Select setting of STR. Lock stitch [Yes].	(5-1)
	Thread & Cloth	1. Is thread used to suit embroidery? (thread twist, tender thread). 1-1 Don't use too strongly twisted thread. 1-2 Twist of thread is to be left-wise. 1-3 Use tender thread. 1-4 Don't use thread with knot or uneven size.	3-1-3

() ----- Reference instruction book

11-2-6 Trouble shooting (Upper thread remains)

Trouble	Factor	Cause of trouble and measure	Page	
Upper thread comes off from needle hole	Environment	1. Does wind let thread go beyond control? (outside wind, heater, and fan etc.) 1-1 Keep the embroidery machine off from wind.	(23-1)	
		2. Is voltage of power as rated and stable? 2-1 Supply rated voltage.		
Upper thread remains	Mechanical	1. Upper thread is difficult to come out of keeper at time of thread cut (bent or warp etc.). 1-1 Modify bent or warp. 1-2 Replace keeper.	3-6-8	
		2. Keeper doesn't return properly at time of thread cut. 2-1 Modify bent of keeper. 2-2 Adjust position to fix. 2-3 Adjust it again if movement is not smooth.		
		3. Upper thread does not come off from magic tape of thread holder. 3-1 Insert something(Thickness 0.1-0.2mm) into holder then move it right and left to put magic tape in order. 3-2 Replacement of magic tape.		3-3-11
		4. Doesn't thread catch hook cut upper thread? 4-1 Polish burr on hook. 4-2 In case hook is in trouble, replace.		
		5. Isn't rubbing of fixed knife and moving knife weak? 5-1 Adjust to be able to rub properly.		3-6-4
	Operator	1. Setting of thread tension is weak. 1-1 Strengthen so as not to cause trouble in sewing rhythm.	(4-5) (8-1)	
		2. Is [Machine settings] properly set? 2-1 Select setting of length of TRD. cut [Normal].	(5-1)	
	Thread & cloth	1. Using hard cloth make thread difficult to go through. 1-1 Select needle and thread.	3-1-4	
		2. Using thick cloth make thread difficult to go through. 2-1 Select needle and thread.	3-1-4	
		3. Is thread used to suit embroidery? (thread twist, tender thread). 3-1 Don't use too strongly twisted thread. 3-2 Twist of thread is to be left-wise. 3-3 Use tender thread. 3-4 Don't use thread with knot or uneven size.	3-1-3	

11-2-7 shooting (Malfunction of thread break detection)

Trouble	Factor	Cause of trouble and measure	Page
Malfunction of thread break detection (empty detection)	Mechanical	1. Trouble in turning detection roller. 1-1 Clean roller shaft holder. 1-2 Check if slit disc doesn't contacts sensor. 1-3 Clean sensor if dust gets stuck. 1-4 Check if cord doesn't contacts slit disc. 1-5 Check Disconnection of cable. 1-6 Check clog of thread detection roller. Roller shaft should have clearance.	
		2. Check circuit board. 2-1 Replace of LCD-CE board. 2-2 Replace of TC 12 board. 2-3 Replace of CONT-D2 board.	4-2
		3. Sometimes needle bar doesn't work when start sewing. 3-1 Replace of needle bar driver. 3-2 Adjust of jump device position. 3-3 Clean and overhaul of Jump device. 3-4 Replace of Jump device.	3-2-6 3-2-7 3-2-14
	Operator	1. No thread is passed through detecting roller. 1-1 Pass thread properly.	(4-7)
		2. Is thread tension proper? 2-1 Observing sewing rhythm, adjust thread tension properly.	(4-5) (8-1)
		3. Is proper detection sensitivity of thread cut selected? 3-1 Select detection sensitivity according to sewing condition of thread and cloth etc.	(5-1)
	Environment	1. Is there any device to yield lints etc. around the embroidery. 1-1 Keep it off the embroidery machine. 1-2 Move the embroidery machine to other place.	
		2. Doesn't thread go beyond control by wind? (thread comes off from needle hole by loosing) 2-1 Keep thread off wind. 2-2 Move the embroidery machine to other place.	
	Thread & Cloth	1. Isn't silicone agent used on thread? (Thread slips at detecting roller part due to adhere of silicone.) 1-1 Clean silicone agent attached to detecting roller groove.	

() ----- Reference instruction book

11-2-7 Trouble shooting (Malfunction of thread break detection)

Trouble	Factor	Cause of trouble and measure	Page
Malfunction of thread break detection (not detected) (slow detected)	Mechanical	1. Check circuit board. 1-1 Replace of LCD-CE board. 1-2 Replace of TC 12 board. 1-3 Replace of CONT-D2 board.	4-2
	Operator	1. Is thread tension proper? 1-1 Observing sewing rhythm, adjust to proper thread tension. (Adjust it little bits stronger.)	(4-5) (8-1)
		2. Is proper detecting sensitivity of thread cut selected? 2-1 Please check [TRD. break detect] in setting menu to except [Off]. 2-2 Select detection sensitivity of thread cut according to sewing condition of thread and cloth etc.	(5-1)

() ----- Reference instruction book

11-2-8 Trouble shooting (Suspension of upper shaft)

Trouble	Factor	Cause of trouble and measure	Page
Suspension of main shaft (E-18) (E-51) (E-52)	Mechanical	1. Upper thread twine round rotary hook or rotary hook retainer. 1-1 Get rid of it.	(23-2)
		2. Check return of keeper goes smooth. (when start sewing, thread cutting. 2-1 Adjust it regularly.	3-6-8
		3. Check upper thread is sticking at thread guide part of bobbin case. 3-1 Get rid of it. 3-2 Do not use of bobbin case in which thread guide is coiled type. (use standard type)	4-5
		4. Effect by breakage of parts. 4-1 Repair broken place.	
		5. No damage in electric parts? 5-1 Replace of LCD-CE board. 5-2 Replace of Timing Board. 5-3 Replace of inverter. 5-4 Replace of CONT-D2 board.	3-8-3 4-2
		6. Trouble of software in LCD-CE board. 6-1 Initialize, then make automatic speed setting.	7-1 7-4
		7. Trouble in control of number of revolution. 7-1 Make automatic speed setting.	7-4
	Operator	1. Isn't foreign stuff such as thread or cloth caught in where revolution is driven. 1-1 Get rid of foreign stuff. 1-2 Stretch properly.	(6-2) (7-5)
		2. Isn't thread tension too strong (stop at time of action of thread cut)? 2-1 Weaken tension so as not to cause trouble in sewing rhythm. 3. Check condition of lubrication. 3-1 Lubricate (refer to message)	(4-5) (8-1)
	Environment	1. Check adequate level of voltage (refer to trip of inverter). 1-1 Supply rated voltage. 100V – 115V -10V / +15V 200V – 230V -10V / +10V	(23-1)

() ----- Reference instruction book

11-2-9 Trouble shooting (Malfunction of needle bar change)

Trouble	Factor	Cause of trouble and measure	Page
Head does not move (E-021) (E-022)	Mechanical	1. Check lint or cloth is seized between Lower Moving rail and Bearing. 1-1 Remove seized lint or cloth.	
		2. Check lint or waste is seized in gap of Moving Cam. 2-1 Remove seized lint or waste.	
		3. Effect by breakage of parts. 3-1 Repair broken place.	
		4. No problem in CONT-D2 board. 4-1 Replace of CONT-D2 board.	4-3
	Operator	1. Check Stopper of Moving Head is removed. 1-1 Remove Stopper.	
Uncontrollable Move (E-024) (E-025)	Mechanical	1. No problem in sensor circuit board ? 1-1 Clean dust attached to sensor. 1-2 Replace sensor circuit board.	3-8-3
		2. Trouble in potentiometer. 2-1 Replace	3-4-2
		3. Needle number is not exactly recognized. 3-1 Recognize needle number with maintenance mode.	8-2
		4. Breakage of Pulse Motor . 4-1 Replace Pulse Motor.	

() ----- Reference instruction book

11-2-10 Trouble shooting (Defect on Thread catcher)

Trouble	Factor	Cause of trouble and measure	Page	
does not catch thread	Mechanical	1. Thead catcher does not extend hook sufficiently. 1-1 Adjust position of Thread catcher 1-2 Adjust position of Thread holder.	3-2-12. 3-3-10	
		2. Excessive distance between Hook and tip of Needle. 2-1 Adjust position of Thread catcher. 2-2 Adjust position of Thread holder.	3-2-12 3-3-10	
	Mechanical	1. Check Hook of Thread catcher bent or not. 1-1 Repair bent Hook. 1-2 Replace Hook.		
		2. Check position of Thread catcher is proper. 2-1 Adjust	3-2-12	
3. Check position of Thread holder is proper. 3-1 Adjust		3-3-12		
Hook of Thread catcher does not extend	Mechanical	4. Check Thread catcher. 4-1 Check cable is securely connected. 4-2 Replace Pulse Motor with trouble.		
		5. No damage in electric parts? 5-1 Replace LCD-CE board. 5-2 Replace of CONT-D2 board.	4-2	
		Mechanical	1. Check Hook is bent or not. 1-1 Repair bent Hook. 1-2 Replace Hook.	
			2. Check position of Thread catcher is proper. 2-1 Adjust	3-2-12
	Operator	3. Check position of Thread holder is proper. 3-1 Adjust	3-3-10	
1. Check if Needle is securely set. 1-1 Set Needle properly.		3-1-2		
Constant display of E-193	Mechanical	1. Trouble of Photo sensor. 1-1 Replace Photo sensor.		

() ----- Reference instruction book

11-2-11 Trouble shooting (Others / Mechanical)

Trouble	Factor	Cause of trouble and measure	Page
Needle Breakage	Mechanical	1. Check Needle is not bent. 1-1 Replace bent Needle.	3-1-2
		2. Check Moving Head set securely. 2-1 Adjust Positioning Roller Shaft.	3-3-3
		3. Secure adequate distance between Needle and Rotary Hook. 3-1 Adjust distance properly.	3-5-1
	Operator	1. Is thread method in proper way? 1-1 Threading again in a proper way.	(4-7)
		2. Check upper thread comes in a smooth way. (Thread stand, Thread tension point, double back etc) 2-1 Adjust place be caught in.	(4-7)
		3. Check whether fabric is fixed firmly or not. 3-1 Hooping fabric firmly again.	(6-2) (7-5)
Defect of pressure foot movement	Mechanical	1. Check whether pressure foot and thread catcher holder touch each other or not. 1-1 Adjust installment position of thread catch holder. 1-2 In case pressure foot is fixed at an angle, fix it vertically again.	3-3-10 3-2-11
		1. By defect of cover installation. (Pressure foot drive, Carriage etc) 1-1 Take care of insert condition, clearance etc and fix again.	
Abnormal noise	Mechanical	2. By lack of oil inside rotary hook. 2-1 Refuel 2-2 Replace of rotary hook	(23-1) 3-5-1
		1. Bearing gap of take up crank ass'y. 1-1 Adjust roller shaft ass'y. 1-2 Replace of roller shaft ass'y.	3-2-8
Big noise	Mechanical	2. Gap between take up lever ass'y and take up clank ass'y. 2-1 Replace of take up lever ass'y. 2-2 Replace of take up lever crank ass'y	3-3-9 3-2-1
		3. Needle bar driver gap of needle bar driver ass'y. 3-1 Replace of needle bar driver ass'y.	3-2-6
		4. Gap between Crank ass'y and Rod ass'y. 4-1 Replace of crank ass'y. 4-2 Replace of rod ass'y	3-2-1 3-2-2
		5. Big gap pressure foot cam 5-1 Replace of take-up lever cam.	3-2-4

() ----- Reference instruction book

12-2-12 Trouble shooting (Others / Electric)

Trouble	Factor	Cause of trouble and measure	Page
Frame overrun	Mechanical	1. Interference between censor circuit board and douser. 1-1 Position adjustment of douser. 1-2 Replace of censor circuit board.	
		2. Check whether cable has problem or not. 2-1 Replace in case damage exists. 2-2 Insert connector again.	
		3. No damage in electric parts? 3-1 Replace LCD-CE board. 3-2 Replace of CONT-D2 board.	4-2
Key on control box can not be pressed down and returned	Mechanical	1. When removing panel in replacing circuit board , due to poor cable bundling, circuit board being pushed from inside. 1-1 Bundle cable again	5-2
Defect of LCD	Mechanical	1. Check LCD . 1-1 Replace of LCD	5-2
		2. Inadequate condition of cable insertion 2-1 Insert to the back firmly	5-2
		3. Check whether LCD-CE board is out of order or not. 3-1 Replace of LCD-CE board	
Defect of data communication (E-90) (E-91)	Mechanical	1. Check whether PC has problem or not.. 1-1 Affirm whether there is problem or not.	
		2. Check whether LCD-CE board is out of order or not. 2-1 Replace of LCD-CE board.	
Watch doesn't indicate time	Mechanical	1. Trouble in back-up battery 1-1 Replace back-up battery.	5-3

() ----- Reference instruction book

P**-P** --- Refer to Happy Link instruction book

11-3-1 Error and measure

When trouble occurred while the machine is running, error number and error item will be displayed. After confirming contents, press button [SET] on control box to release error, then restore in accordance with measure in this list.

No.	Message	Error	Measure	Page
001	Circuit board	Trouble detected in control circuit board.	(1)Turn power off once and turn on again. (2)If recurred, replace LCD-CE board.	
002	Power source	Power failure or abnormal voltage	Replace LCD-CE board.	
004	System memory	Trouble in system memory.	Replace LCD-CE board.	
014	Fan Alarm	Cooling fan on CONT-D2 board fault	(1)Clean dust attached to fan. (2)Replace fan.	4-4
015	Inverter trip	Trouble in drive unit on main shaft. Overload on main shaft motor, damage in drive unit on main shaft.	(1)Turn power off, turn main shaft by hand and if no trouble found, turn power on again. (2)If trouble found, repair where damaged. (3)If inverter in trouble, replace. (4)Check if voltage high or not. If high,check origin of power source of factory. Or use stabilizer, transformer to set to rated voltage.	6-1-1
016	Alarm X unit	X-motor-related trouble, i.e. x-motor overload, short circuit, problem with motor drive unit	(1)Power off machine, test pantograph movement manually. Check for any abnormality throughout full range of motion. If none found, power on again.	4-2
017	Alarm X unit	Y-motor-related trouble, i.e. y-motor overload, short circuit, problem with	(2)Check related harnes. (3)Replace drive-A circuit board.	
018	Main shaft	Suspension of main shaft in mid way.	(1)Check if trouble found between main shaft and drive. If trouble found, restore. (2)If recurred, find cause and fix. (3)Make automatic speed setting again.	7-4
020	Needle detect	Needle position not detected. Trouble in stop position of needle selection unit.	(1)Turn needle selection cam by hand to set to regular position. (2)Fix needle selection related mechanical trouble. (3) Replace sensor circuit board or potentiometer.	3-4-2
021 022	Needle move	Suspension of needle selection motor in mid way. Trouble in take-up lever hinders. Trouble in position detecting circuit board.	(1)Turn needle selection cam by hand to set to regular position. (2)Fix needle selection related and take up lever related troubles. (3)Replace sensor circuit board or potentiometer.	3-4-2

() ----- Reference instruction book

No.	message	Error	measure	page
024	Needle center	Stop position of needle bar is off center	(1)Turn needle selection cam by hand to set to regular position. (2)If trouble occurs repeatedly, fix mechanical trouble in needle selection & its vicinity.	
025	Needle over	Specified needle number went beyond needle number of the machine.	Adjust position of needle selection cam (potentiometer) and needle number of moving head.	3-4-3
026	Needle differ	As needle number differed from memory when power turned on, it was renewed.	(1)Turn power off once and turn on again. (2)Let the machine recognize needle number.	3-4-3
030	Slow mismatch	Inadequate adjustment of number of low speed revolution. Low speed revolution doesn't come below 100rpm.	(1)Make automatic speed setting. (2)If not solved even after speed adjustment, replace LCD-CE board.	7-4 5-2
050	C point	Main shaft stops off its position.	(1)Turn main shaft to plus direction to set to C point.	(24-1)
051	L sensor	Poor lowest needle position sensor on timing detecting circuit board. Damage in timing detecting circuit board, stained photo sensor, poor adjustment of slit disc.	(1)If photo sensor is stained, clean. (2)Adjust timing. (3)Replace main shaft timing circuit board.	3-8-4
052	C sensor	Damage in color change point sensor on timing circuit board. Damage in timing detecting circuit board, stained photo sensor, poor adjustment of slit disc.		
060	X limit	Drive frame went beyond limits in X direction.	(1)Move drive frame back to limits with move key.	
061	Y limit	Drive frame went beyond limits in Y direction.	(2)Correct pattern size and setting contents.	
063	Drive Setup	During embroidery, preparation for frame movement did not complete within predetermined time.	(1) Malfunction of "Lowest needle position" sensor on detection circuit board, Improper adjustment. (2) Make automatic speed setting.	3-8-3 7-4
064	X Center sens.	Trouble in embroidery frame sensor	(1) Check if position sensor is dirty. Turn off power source, then turn on again.	3-7-5 3-7-6
065	Y Center sens.		(2) Setup mistake of the machine parameter (3) Replace position sensor circuit board.	8-5
066	Frame drive	Frame movement did not complete during origin point movement.	(1) Dirt L point sensor [PH1] or wrong position of slit. (2) Dirt timing slit, position adjustment (3)Replace timing circuit board.	3-8-4 3-8-3 3-8-3
067	L sensor	Consumption of embroidery frame coordinate data.	Adjust position sensor position on carriage. Then register frame position again.	8-6

No.	message	Error	measure	page
068	Position set	Failure to read embroidery frame sensor signal. (Return)	(1)Check if position sensor is dirty. Turn off power source, then turn on again.	3-7-5 3-7-6
069	Position Entry	Failure to read embroidery frame sensor signal. (Entry)	(2) Setup mistake of the machine parameter (3) Replace position sensor circuit board.	8-5
070	Safety sensor	Safety sensor has been tripped.	(1)Clear area around safety sensor. (2)Check material dose not shut out safety sensor beam. (3) Adjust safety sensor position.	7-1-3
090	Miss reception	Error has occurred during data transfer (via cable) between machine and PC.	(1)Let the machine read pattern data from first.	(5-6)
091	No send	Data is not put in for over 10 seconds.	Let the machine read data from first.	(5-6)
103	Data format	Machine unable to determine format of pattern data.	(1)Check format of pattern data. (2)By setting reading of pattern data,	(14-4)
104	Miss function	Timing to read pattern data doesn't conform.	Read pattern data again from the first.	(5-6)
105	Dual function	One stitch data has more than 2 functions.	(1)Read pattern data again from the first. (2)Check and modify the design data if there is wrong.	(5-6)
106	No function	Interval between start read time and time of reception of actual pattern data	Read pattern data again from the first	(5-6)
108	Improper read	While reading pattern data, there accrued error in internal processing.	Read pattern data again from the first.	(5-6)
110	Memory full	While reading pattern data, memory exceeded its capacity.	(1>Delete unnecessary patterns and read from the outset.	(5-B)
111	Change over	While reading pattern data, the frequency of color change (color No.) exceeded 250 times.	(1)Modify pattern data and reduce frequency of color change of one pattern to less than 250 times. (2)Divide pattern data and reduce frequency of color change of one pattern to less than 250 times.	
112	Data error	Pattern data of pattern to be embroidered is damaged.	(1)Read pattern data again from the first. (2)Read pattern data again if you have a backup data.	(5-B)
114	Id over	The number of pattern in memory has reached maximum of 99.	Delete unnecessary patterns and read.	(5-B)
116	Not found Id	Specified pattern does not exist.	(1)Check setting. (2)Re-initialize machine system.	7-4
118	Trace data over	The stitch number counts over 1024 stitches during preparing Trace data.	Set Embroidery area of pattern data within 2m(X) x 2m(Y).	

() ----- Reference instruction book

No.	message	Error	measure	page
120	Memory error	It became impossible to retain contents of memory.	(1) Turn power off once and turn on again. (2) If problem recurs frequently, replace LCD-CE board.	5-2
130	Disk error	Unable to communicate continuously with memory media.	(1) Turn off power source once and turn it on again. (2) Memory media reading processor may be defective. Replace the LCD-CE board.	5-2
131	Device no ready	Memory media is not set.	Check if memory media is properly set.	(5-5)
133	Bad disk	Improper or faulty memory media.	(1) Memory media might be not readable with the machine. Prepare readable memory media for the machine. (2) Memory media might be defective. Prepare another memory card or data disk which is not defective. (3) Initialize the memory media if it is not initialized.	(5-5)
141	Not found name	Designated pattern is not found.	Memory media might be not readable with the machine. Prepare readable memory media for the machine.	(5-5)
142	Disk full	Memory media is full to capacity.	Clear unnecessary patterns or use a different memory media.	
143	Multi name	Another pattern with same name has been detected while attempting to write to memory media.	Change name, use a different memory media, or overwrite existing pattern.	
190	Cut blade	Thread cut knife is not at stop position.	1) Restore the moving knife to stop position. (2) Check dirt of trim sensor or position of slit. (3) Modify the adjustment if the problem repeats. (4) Adjust sensor position.	(24-6)
193	Catcher	Thread catch hook is not in its stop position.	(1) Check if mistake is found in thread cut. If found, cut thread and move thread catch hook to proper position. (2) Adjust and correct trouble that hinders motion of thread catch hook.	(24-8)

() ----- Reference instruction book

No.	message	Error	measure	page
215	Frm. drive err	Frame movement did not complete. during normal movement. (Time over)	(1) Check timing sensor unit and slit. (2) Update program	7-2, 7-3a
217	Frm.drive data	Frm.drive data	Update program.	7-2, 7-3a
255	Default Error	During embroidery, frame movement did not complete until main shaft reach "Lowest needle position".	Re-initialize machine speed setting. Check adjustment of upper shaft timing. (C point / L point)	7-4

() ----- Reference instruction book

11-4-1 Tables for timing / adjustment value

		Tables for Timing/Adjustment value
Take-up lever timing		0 degrees
Rotary hook timing		23 degrees
Needle height		5 degrees
Main shaft timing	L	LED4 light out at 0 degrees(Clockwise)
	C	LED3 light on at 270-284 degrees(Clockwise)



2014 / 3

HAPPY Industrial Corporation

9-5. TAITO 2-CHOME, TAITO-KU, TOKYO, JAPAN

TEL +81-3-3834-0711

FAX +81-3-3835-8917