

HCS c

Computerized Compact Single Head Embroidery Machine

INSTRUCTION BOOK

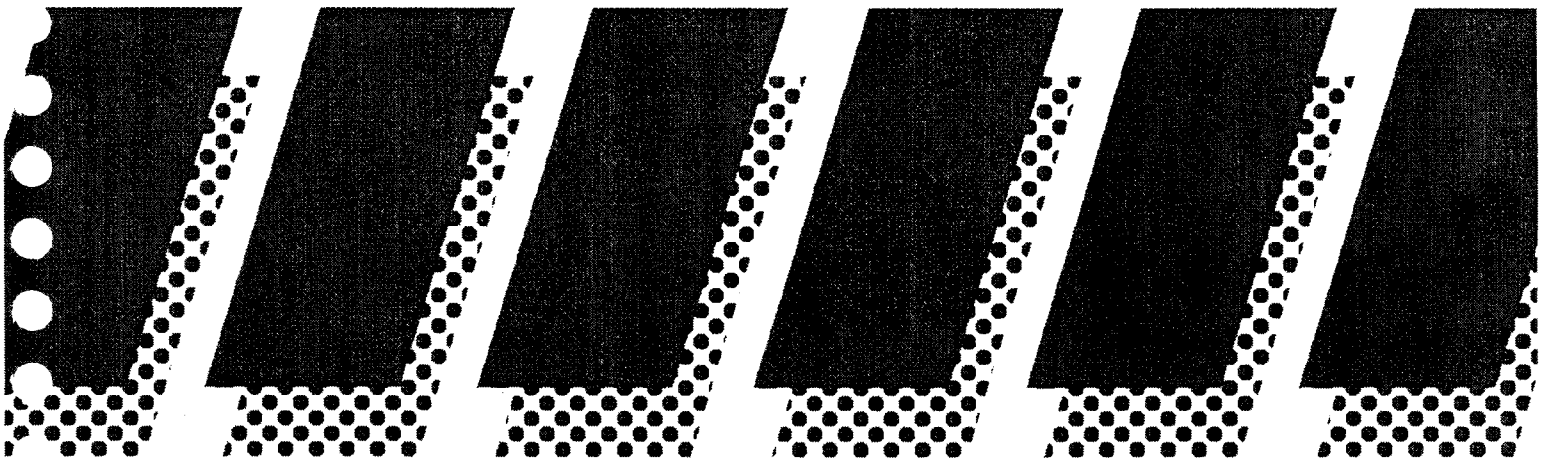

HAPPY Industrial Corporation

LET'S GET STARTED GUIDE

Please remove this page from the binder and use it with machine operation.

① Card (Load your design from memory card to the machine memory)

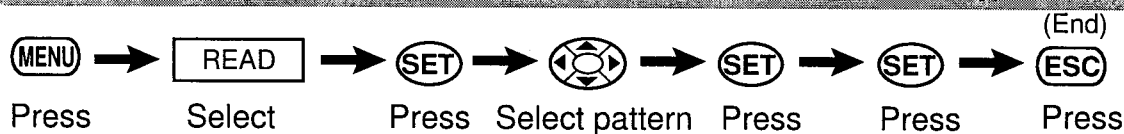

② Pattern (Select pattern from machine memory)

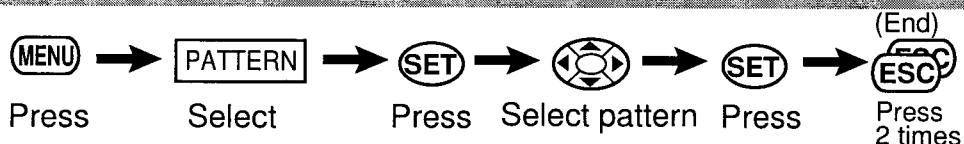

Selected design has last seated function (Needle, Convert,

③ Needle (Color change setting)

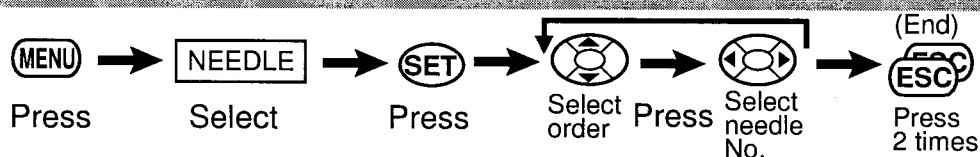

Then, move frame to start point. And press "START" button for machine.

④ Erase Design from Machine Memory

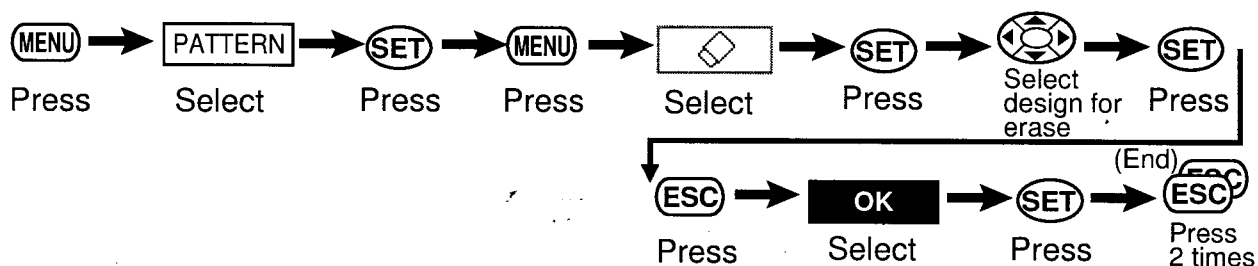

⑤ Adjust "WIDTH" for satin stitches

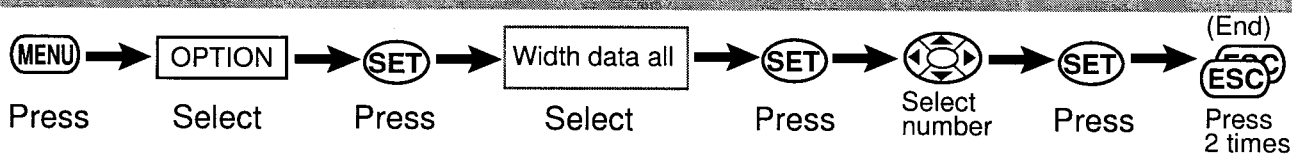

You can Increase and Decrease the width of only satin stitch In all your design. Limited from -1.0 to +1.0mm.

⑥ "Position" for Direct jump move to any stitch point in the design

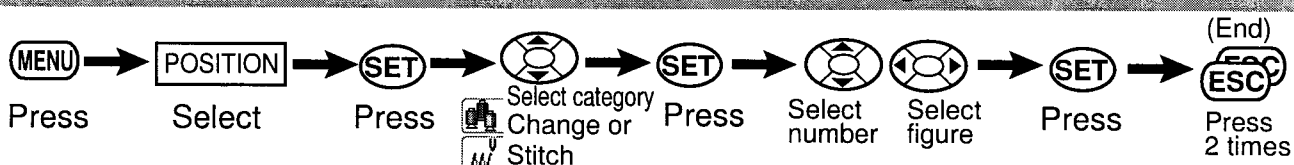

Change: Number of color change point. Frame move to first stitch point in the color.
Stitch : Number of stitch point as you want to direct jump.

LET'S GET STARTED GUIDE

7 DRIVE KEY

FORWARD

FWD

The embroidery frame advances one stitch when pressed once. If you keep pressing, the frame goes forward continuously.

PRESSURE FOOT

P.FOOT

You can raise or lower the pressure foot.

THREAD CUT

CUT

Machine will cut the upper and lower thread when this button is pressed.

8 FUNCTION MENU

ORIGINAL POINT RETURN

FUNC



Origin



SET

Press

Select

Press

Embroidery frame returns to original point (Start point) of the design, and stitch to start sewing returns to top of design data.

TOP

FUNC



Top



SET

Press

Select

Press

Position to start sewing returns to top of embroidery data.

FRAME CENTER

FUNC



Center



SET

Press

Select

Press

Move embroidery frame position to be the center, and position to start sewing returns to top of design data.

POSITION RETURN

FUNC



Position



SET

Press

Select

Press

If you move the embroidery hoop in the middle of a design, embroidery frame return to previous position.

If you need more detail or other function, Please see instruction book.

IMPORTANT SAFETY INSTRUCTIONS ..	1-1	Reading embroidery pattern data from the PC	5-4
WARNING LABELS & THEIR LOCATIONS	1-2	Reading embroidery pattern data from memory cards	5-5
SETTING UP THE MACHINE		How to select patterns from memory	5-A
Remove the machine from box	2-1	Erasing patterns from memory	5-B
Accessories	2-2	Erasing all designs	5-D
Assemble machine unit	2-3	NEEDLE BAR SELECTION	5-E
Machine installation	2-4	SEWING WITH TUBULAR FRAMES	
Grounding instruction	2-6	Installing and removing the frame base ..	6-1
MAIN PARTS	3-1	How to hoop	6-2
HOW TO READ THESE INSTRUCTIONS	3-3	Putting the hoop on the machine	6-3
MESSAGE	3-4	Starting to embroider	6-4
TURNING THE MACHINE ON		CAP FRAME (OPTION)	
How to turn on the machine	3-5	Cap frame setting	7-1
Display contrast	3-6	Changing the needle plate	7-2
Calendar and clock setting	3-7	Installing and removing the cap drive frame ...	7-3
THE CONTROL BOX	3-8	Normal cap frame	7-5
DRIVE MODE	3-A	Wide cap frame	7-8
DRIVE MENU	3-B	Starting to embroider	7-B
MENU	3-C	ADJUSTING THE THREAD TENSIONS ..	8-1
GUIDE	3-D	SEWING	
INSERTING A NEEDLE	4-1	What to do if the thread breaks while sewing .	9-1
SELECT NEEDLES AND THREADS	4-2	Stopping and resuming sewing	9-1
BACKING MATERIALS	4-3	Loss of power while embroidering	9-2
BOBBIN WINDING		Moving the hoop while embroidering and then returning to the correct location (Position)	9-3
Winding the bobbin	4-4	Moving back to the starting point (Origin) ..	9-3
Removing the bobbin	4-5	Going back to the beginning of the design (Top)	9-4
Inserting the bobbin	4-5	Placing the design in the center of the selected embroidery frame (Center)	9-4
Adjusting bobbin thread tension	4-5	Rotating and mirroring designs (Convert) ...	9-5
Inserting the bobbin case	4-5	Starting in the middle of a design (Position) ...	9-6
THREADING THE MACHINE		DISPLAYING THE PATTERN IN SETTING MODE .	10-1
How to thread upper thread	4-6		
MACHINE SETTINGS	5-1		
PREPARATION OF PATTERN DATA			
Connecting to a PC by Serial or USB connection ...	5-4		

PATTERNS IN MEMORY		OTHER SETTINGS	
Locking pattern data	11-1	Create network	22-1
Trace type	11-2	Version information	22-3
Renaming patterns	11-3	SPECIFICATIONS • MAINTENANCE	
Copying pattern data	11-4	Specifications	23-1
PATTERN SETTINGS	12-1	Oiling	23-1
Scaling	12-2	Cleaning of rotary hook	
Width adjustment	12-3	Cleaning of thread cutting knife	23-2
Angle	12-4	ERRORS AND WHAT TO DO	24-1
Repeat sewing	12-5	INITIALIZING OF MACHINE SETTINGS	
Auto origin	12-7	Re-Initialization of machine system	25-1
Offset	12-8	Initializing of machine speed	25-2
Frame out	12-D	HELPFUL HINTS	26-1
NEEDLE BAR SELECTION	13-1	EMBROIDERY TERMS	26-2
Auto setting	13-2	BUILT-IN FONT LIST	26-3
Thread color	13-3		
Color change data registration	13-5		
Color change data read	13-6		
READING			
Pattern Read Settings	14-1		
Restoring settings	14-4		
MACHINE SETTINGS			
Initialization of setting	15-1		
POSITION	16-1		
Piece number	16-2		
LETTER	17-1		
DATA EDIT			
Stitch selection	19-1		
Zoom in for the display	19-4		
Zooming rate	19-5		
Function code	19-6		
Insert stitch•Erase stitch	19-8		
Finish editing	19-A		
FRAME CONFIRMATION	20-1		
Tubular round frame, Tubular square frame	20-2		
Cap frame	20-4		

When using an electrical appliance, basic safety precautions should always be followed, including the following.

Read all instructions before using this appliance.



DANGER - To reduce the risk of electric shock:

1. An appliance should never be left unattended when plugged in. Always unplug this appliance from the electric outlet immediately after using and before cleaning.



WARNING - To reduce the risk of burns, fire, electric shock, or injury to persons:

1. Do not allow to be used as a toy. Close attention is necessary when this appliance is used by or near children.
2. Use this appliance only for its intended use as described in this manual. Use only attachments recommended by the manufacturer as contained in this manual.
3. Never operate this appliance if it has a damaged cord or plug, if it is not working properly, if it has been dropped or damaged, or dropped into water. Return the appliance to the nearest authorized dealer or service center for examination, repair, electrical or mechanical adjustment.
4. Never operate the appliance with any air openings blocked. Keep ventilation openings of the sewing machine and foot controller free from the accumulation of lint, dust, and loose cloth.
5. Never drop or insert any object into any opening.
6. Do not use outdoors.
7. Do not operate where aerosol (spray) products are being used or where oxygen is being administered.
8. To disconnect, turn all controls to the off ("0") position, then remove plug from outlet.
9. Do not unplug by pulling on cord. To unplug, grasp the plug, not the cord.
10. Keep fingers away from all moving parts. Special care is required around the sewing machine needle.
11. Always use the proper needle plate. The wrong plate can cause the needle to break.
12. Do not use bent needles.
13. Do not pull or push fabric while stitching. It may deflect the needle causing it to break.
14. Switch the sewing machine off ("0") when making any adjustments in the needle area, such as threading needle, changing needle, threading bobbin, or changing presser foot, etc.
15. Always unplug sewing machine from the electrical outlet when removing covers, lubricating, or when making any other user servicing adjustments mentioned in the instruction manual.

SAVE THESE INSTRUCTIONS

Trapping hazard

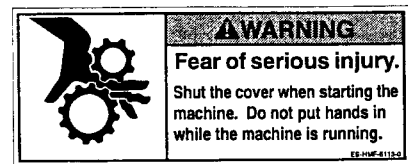

Trapping hazard wherever this label is found



Power Supply Voltage sticker

Risk of electrical shock and fire if the power recommendations on this label are ignored!

Make sure that the power supply meets the exact specifications as provided by the manufacturer.

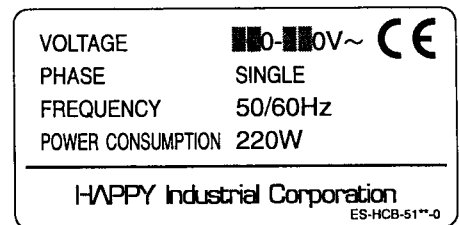

Injury risk warning for all needles

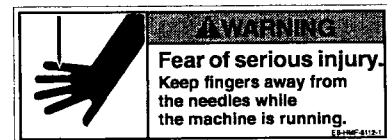

Shock hazard on all electrical components



Injury risk on moving head(s)

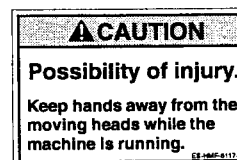

Injury risk on frame and carriage



We recommend unpacking should be done where it has enough room.

! CAUTION : To prevent accidents.
 The machine is quite heavy for one person to carry. Please use two persons when unpacking or carrying.

! CAUTION : To avoid troubles.
 Make sure to hold bottom of the machine body when removing from the box. Do not hold any other place. (bed, moving head, control box etc.).

■ Confirm all the accessories are contained when unpacking.

▼ Remove the machine from box

1. Remove 2 straps [1] from the carton.
 2. Lift the box (upper) [2] to remove.
 3. Take out the accessories. (Refer to the next page.)
 4. Take out the styrene foam (right) [3] and (left) [4].
 5. Take out the styrene foam (lower front) [5], (lower right) [6], and (lower left) [7].
- * Be careful not fall down the machine, tilt the machine slightly when taking out the styrene form (lower right) and (lower left).
6. Carry the machine to installation location.

■ Please keep those packing materials in case of necessary for repair or other reasons.

■ Packing procedure is the reverse from unpacking procedure.

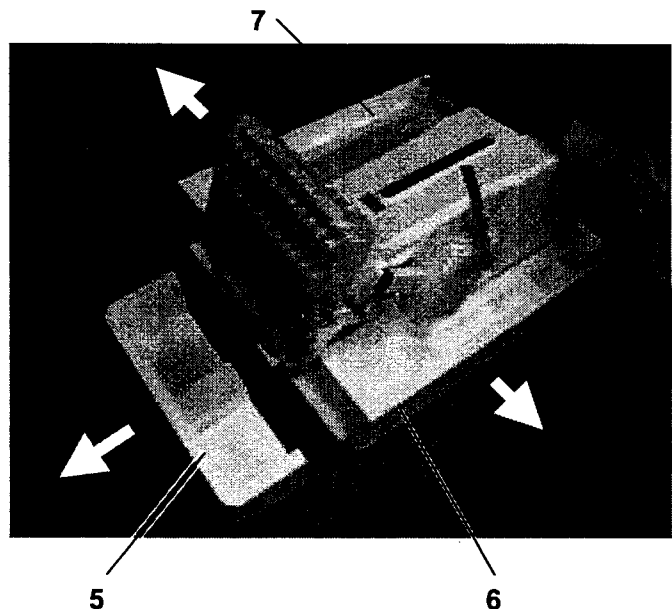
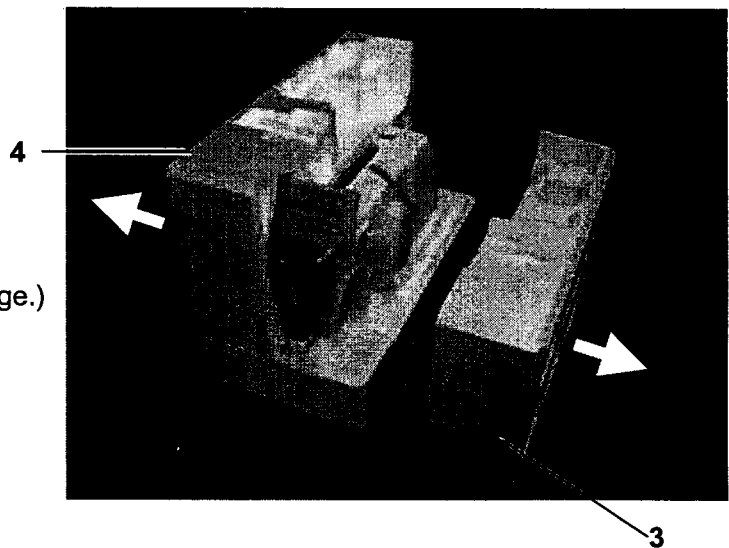
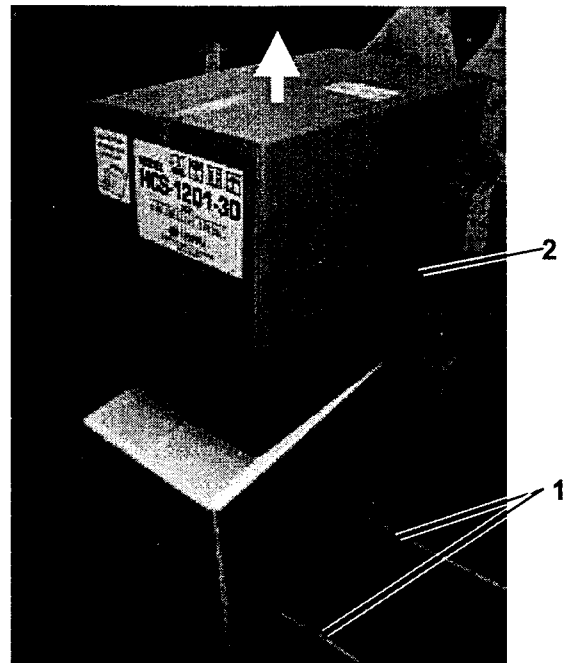

Placement of Accessories

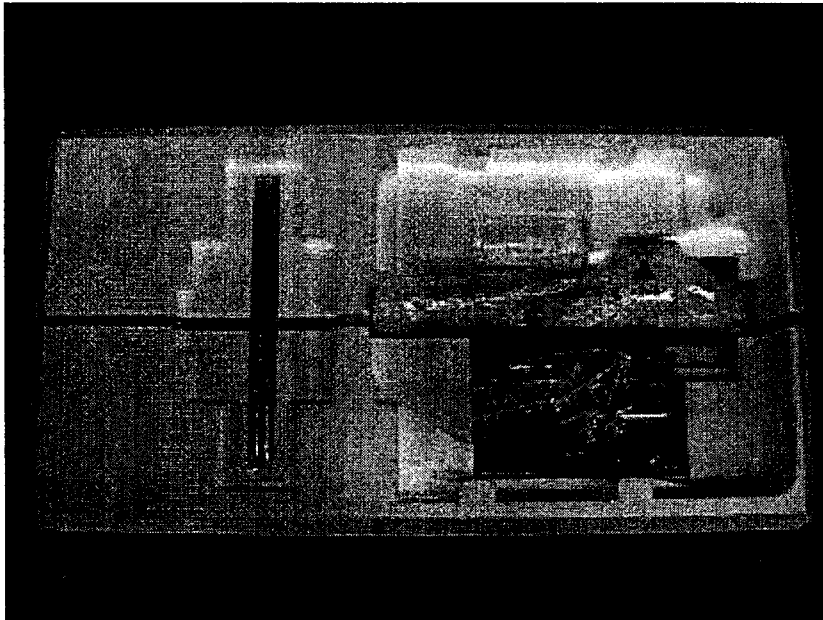

- Carriage
- Spool felt (13 pieces)
- Serial cable
- Power line cord ass'y
- Tool set
- Needle (10 pieces)
- Bobbin (2 pieces)
(1 piece set to rotary hook)
- Fuse (6A)
- Oiler
- Thread guide pillar (2 pieces)
- Thread stand pin (13 pieces)
- Wave washer (13 pieces)

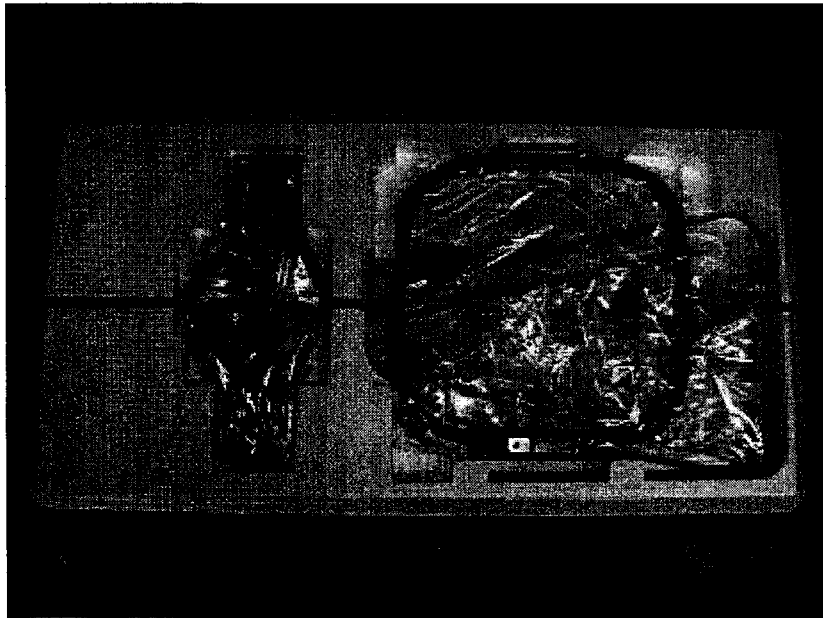

- Embroidery frame (round)
- Embroidery frame (square)
- Thread stand
- Thread guide bracket

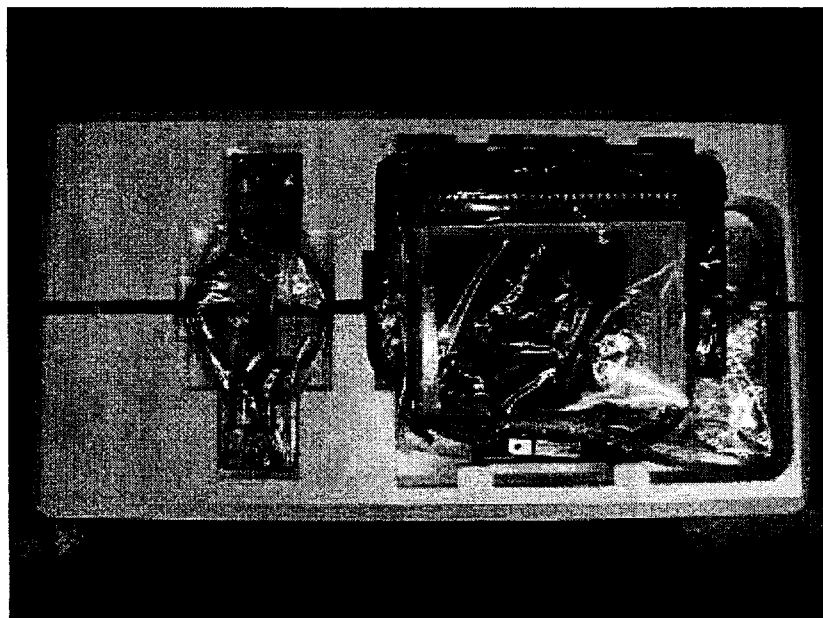

- Frame base
- CD-ROM (Happy Link Software)
- Instruction book
(Embroidery machine /
Happy Link Software)
- Parts list book
- Embroidery sample

SETTING UP THE MACHINE

2-2

●Accessories

Please confirm you have received the following.

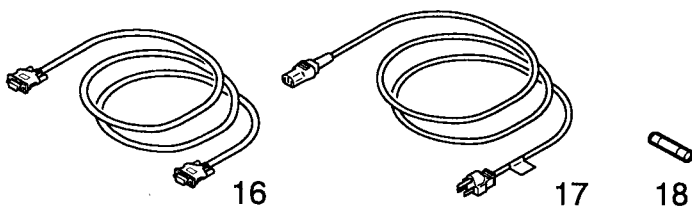
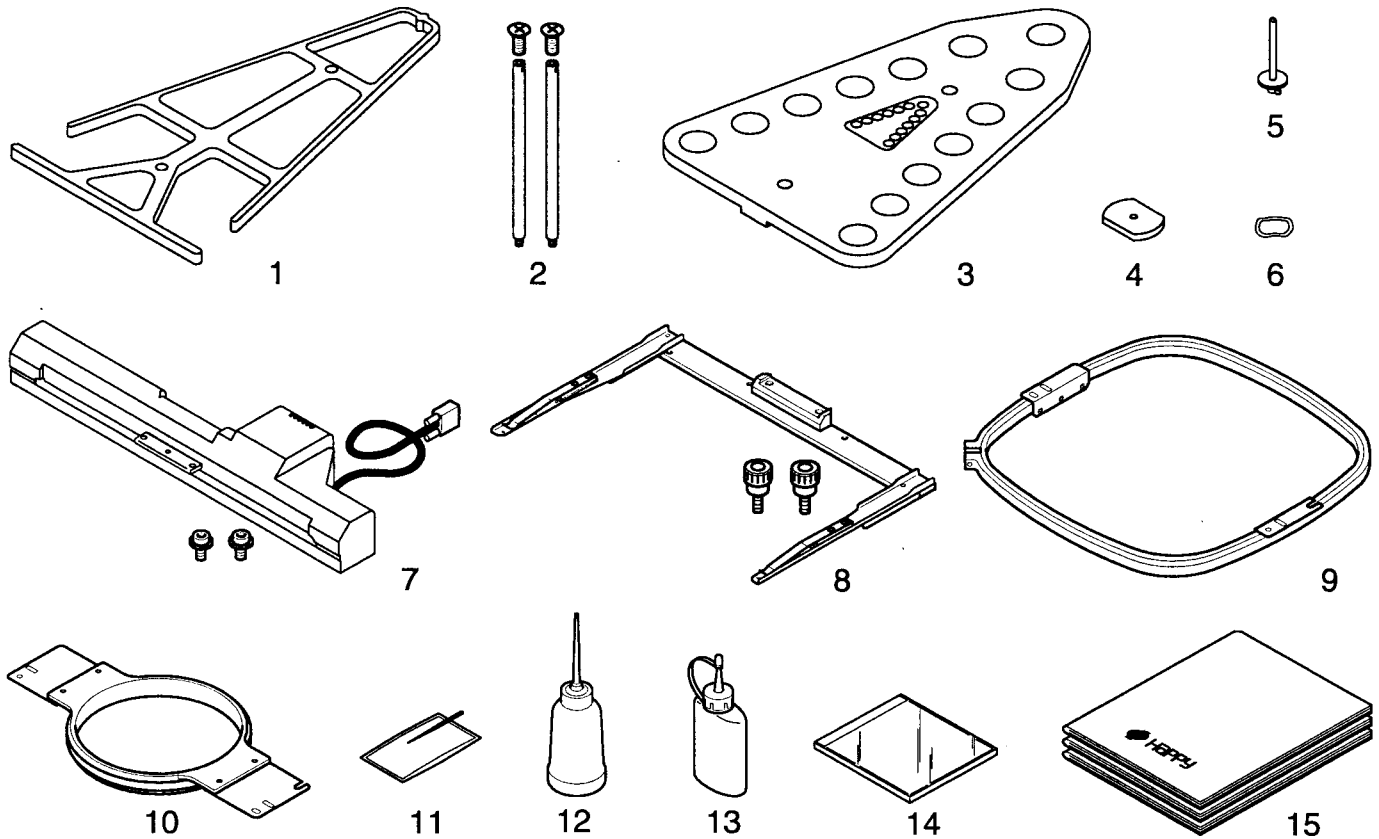

1. Thread guide bracket
2. Thread guide pillar (2 pcs)
3. Thread stand
4. Thread stand felt (13 pcs)
5. Thread stand pin (13 pcs)
6. Wave washer (13 pcs)
7. Carriage
8. Frame base
9. Embroidery frame (square) PTA-32320
10. Embroidery frame (Round) PTA-180-360
11. Needle (DB X K5) (10 pcs)
12. Oiler
13. Sewing machine oil
14. CD-ROM
15. Instruction book (Machine, Happy Link)
16. Serial cable
17. Power line cord ass'y (A shape will be changed depending on a destination)
18. Fuse (6A)

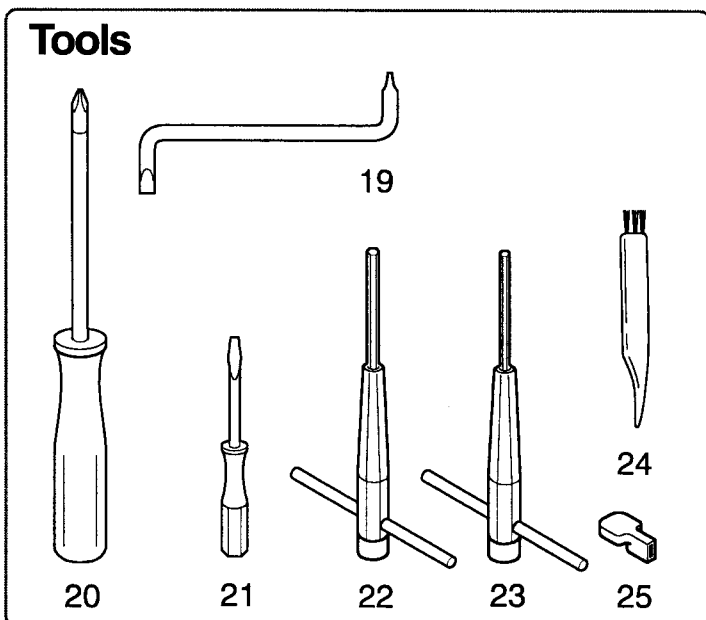

SETTING UP THE MACHINE

2-3

● Assemble machine unit

1. Insert the thread stand pin with wave washer on the thread stand by turning clockwise, Then insert thread stand felt.
 2. Put the thread stand on to the machine and insert the thread guide pillar. Turn the thread guide pillar clockwise with a 3 mm hexagonal driver until tight.
 3. Install the thread guide bracket with supplied screws (pan head screw M6 X 10 2 pcs).
 4. Loosen the screw with a offset driver and remove the red shipping collars that are equipped on the both side of the guide bar. (Keep the shipping collars. It is necessary when packing.)
 5. Put the carriage and carriage arm together with screw (M4 X 8 2 pcs). 2 pins in the upper carriage arm will fit into holes on the lower carriage.
 6. Raise slowly the control box to the front then fix it with 2 supplied screws (M4 X 8 2 pcs).
 7. Connect the cable of carriage to the machine with fixed screw.
 8. Install the arm for tubular embroidery. Please refer to (page 6-1) "Installing and removing the frame base". Or, Install the cap frame for the cap embroidery. Please refer to (page 7-1) "Installing and removing the cap drive frame".
- When taking the machine apart in case of packing, the process is opposite of assembling the machine. Please do exactly the opposite way of assembling.
 - When packing the machine up for transportation, be sure to select the sixth needle and fix it with shipping collars on the both side of the guide bar.

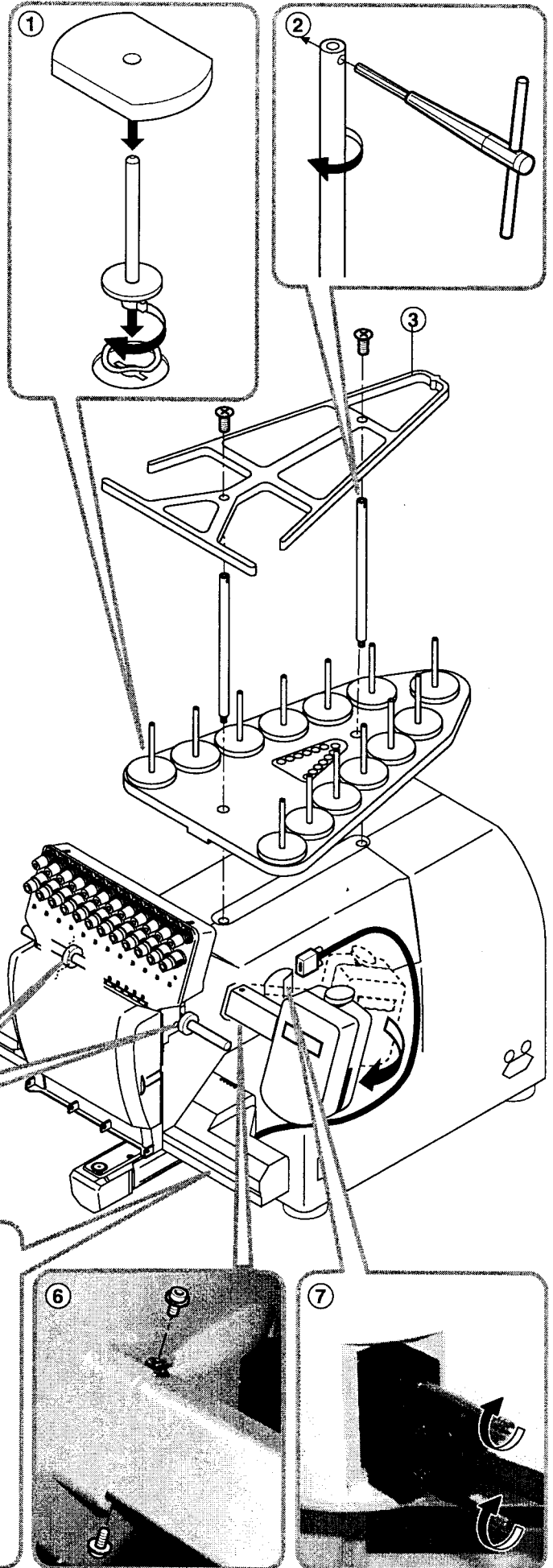

● Machine installation

1. Please use a stout table to set the machine on.

Please check for any shaking or excessive vibrating of the machine table when the machine is running.
If you have a problem, Please use a stronger table for the machine.

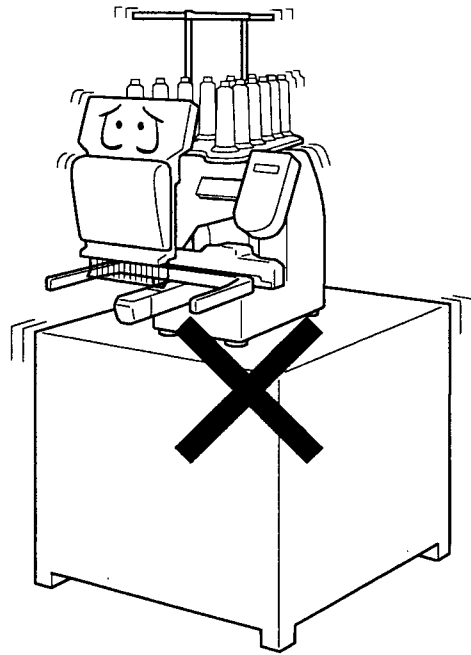

2. Please sit the machine level on the table.

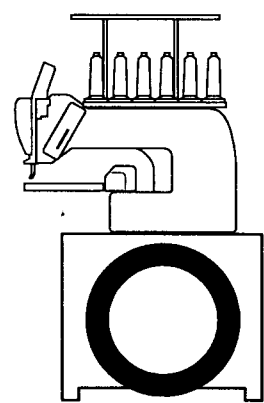
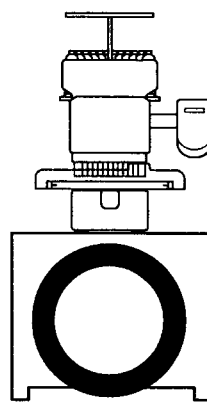
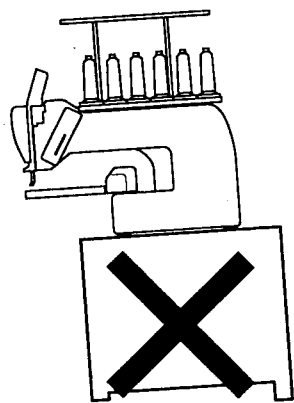
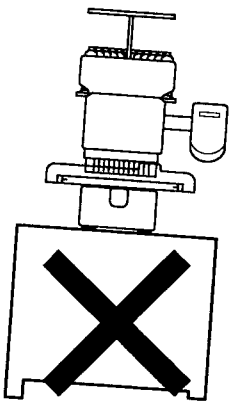

3. Please be sure you have this much room around your machine for it to move.

It is possible for the embroidery frame to hit you and cause injury.

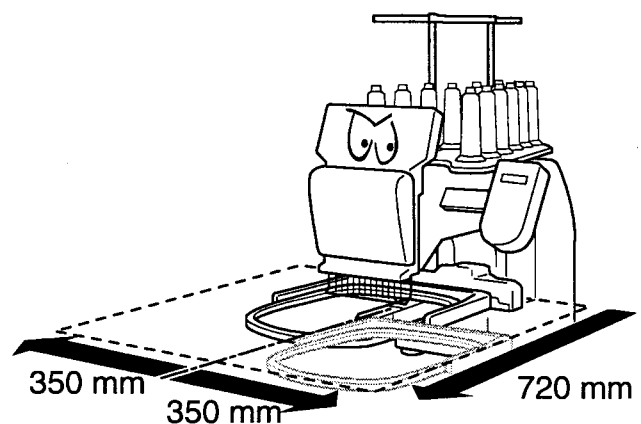

4. Please be sure you have this much room around your cap drive for it to move.

Please machine on the table positioning like right side drawing.

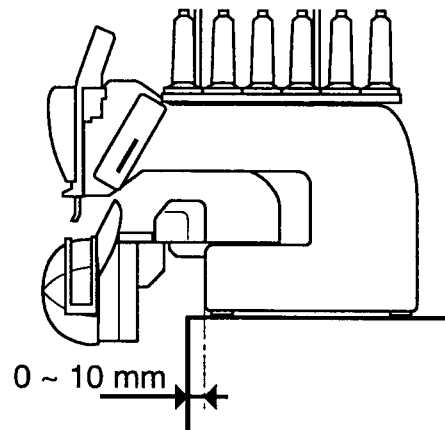

5. Please do not sit the machine near any kind of other electric equipment (Examples: Microwave or electric tool).

Has possible to wrong movement of the machine.

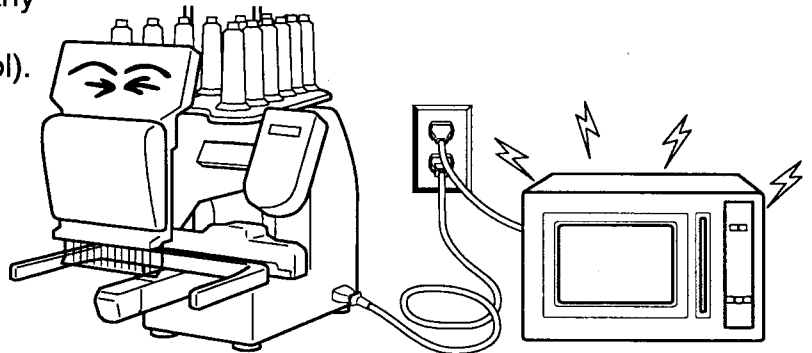

6. Please keep away from dusty and high moisture environments.

Has case of rusting or damaging.

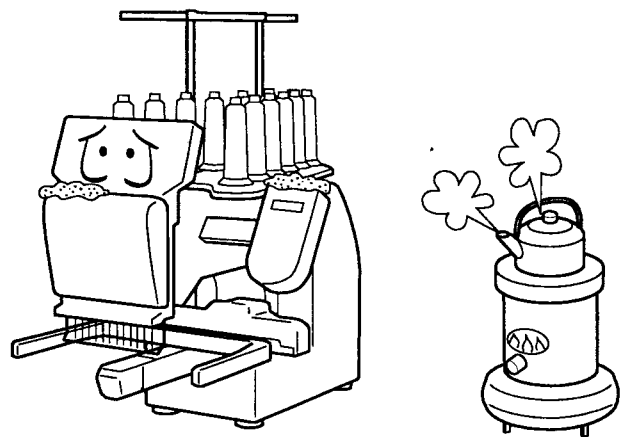

7. Please do not sit the machine in direct sunshine or windy locations.

Has case of rusting or damaging.

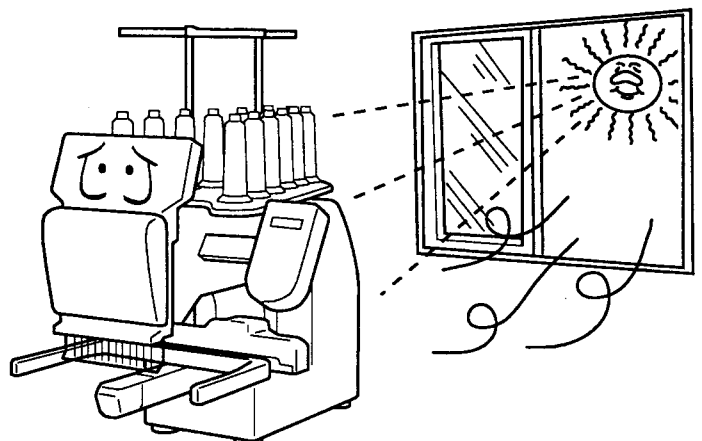

● Grounding instruction (for type of 120V)

This product must be grounded. In the event of malfunction or breakdown, grounding provides a path of least resistance for electric current to reduce the risk of electric shock. This product is equipped with a cord having an equipment-grounding conductor and a grounding plug. The plug must be plugged into an appropriate outlet that is properly installed and grounded in accordance with all local codes and ordinances.

⚠ DANGER – Improper connection of the equipment-grounding conductor can result in a risk of electric shock. The conductor with insulation having an outer surface that is green with or without yellow stripes is the equipment-grounding conductor. If repair or replacement of the cord or plug is necessary, do not connect the equipment-grounding conductor to a live terminal.

Check with a qualified electrician or serviceman if the grounding instructions are not completely understood, or if in doubt as to whether the product is properly grounded.

Do not modify the plug provided with the product – if it will not fit the outlet, have a proper outlet installed by a qualified electrician.

This product is for use on a nominal 120 V circuit, and has a grounding plug that looks like the plug illustrated in sketch A in Figure. A temporary adaptor, which looks like the adaptor illustrated in sketches B and C, may be used to connect this plug to a 2-pole receptacle as shown in sketch B if a properly grounded outlet is not available. The temporary adaptor should be used only until a properly grounded outlet can be installed by a qualified electrician. The green colored rigid ear, lug, and the like, extending from the adaptor must be connected to a permanent ground such as a properly grounded outlet box cover. Whenever the adaptor is used, it must be held in place by the metal screw.

Grounding methods

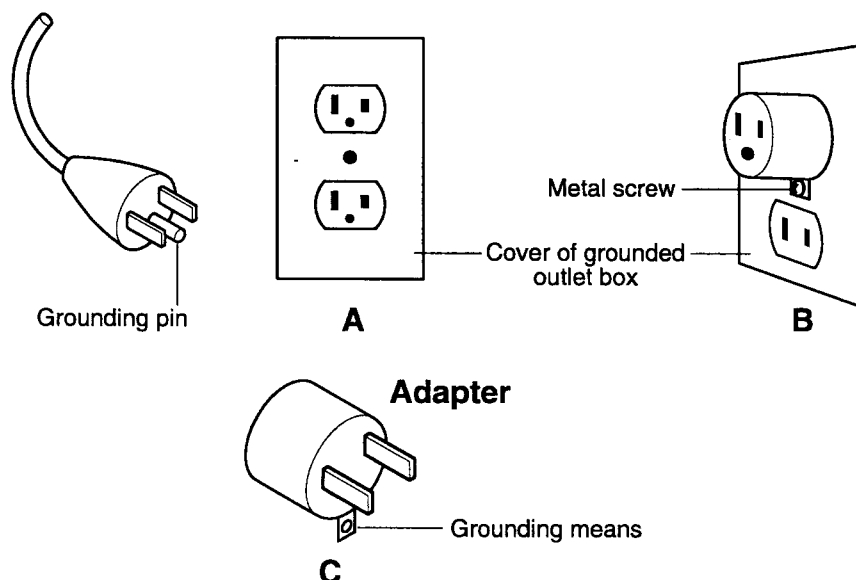

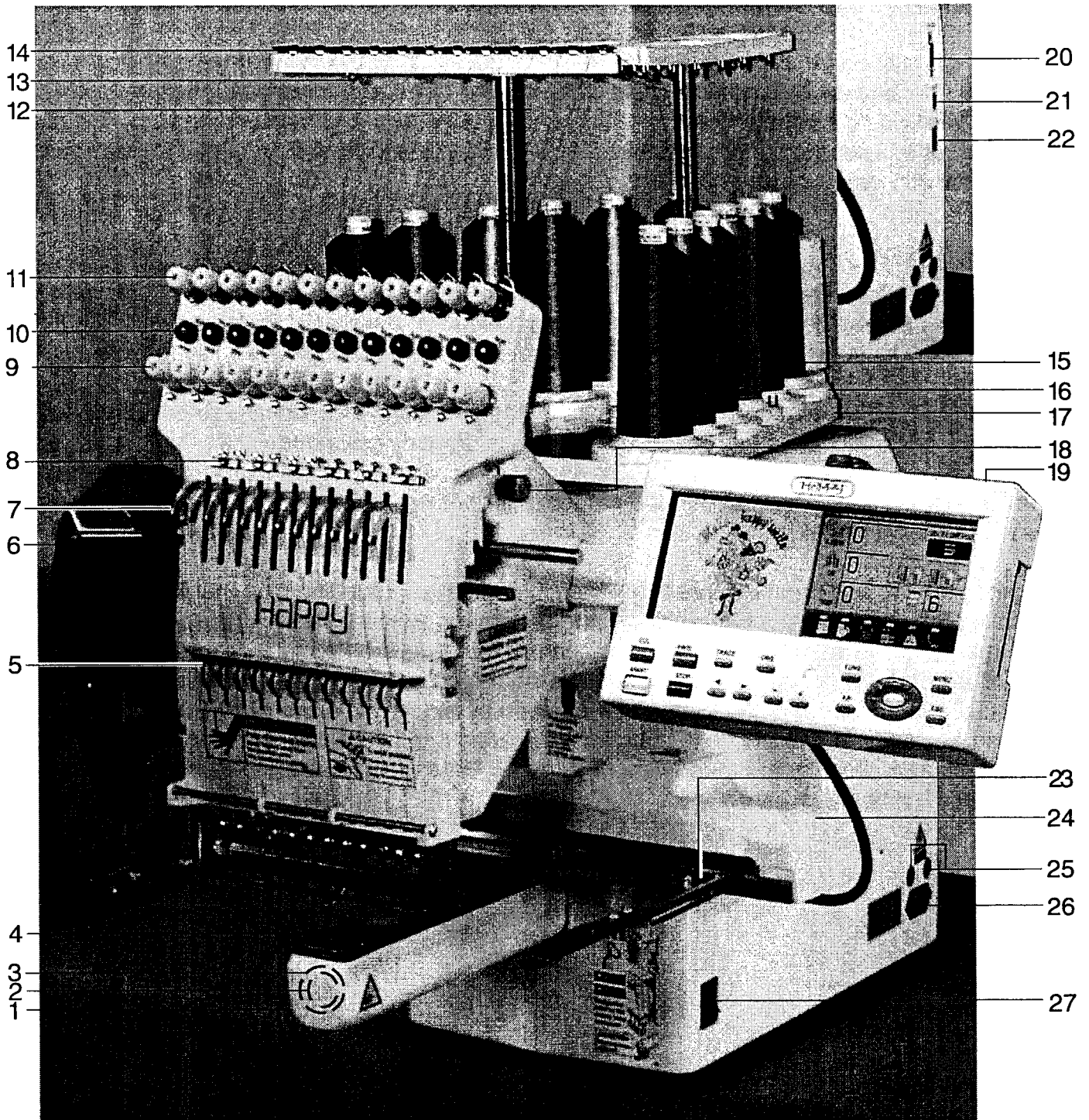

- | | | |
|------------------------|-------------------------------|---------------------------------|
| 1. Hook cover | 11. Minor thread tension | 21. USB port (based on the USB) |
| 2. Bobbin case | 12. Thread guide support | 22. LAN port |
| 3. Hook | 13. Thread guide | 23. Frame base |
| 4. Needle plate | 14. Upper rectifier | 24. Carriage |
| 5. Thread check spring | 15. Thread stand pin | 25. Fuse (6A) |
| 6. Take-up lever cover | 16. Thread stand felt | 26. Terminal box |
| 7. Take-up lever | 17. Thread stand | 27. Power switch |
| 8. Lower rectifier | 18. Needle bar selection knob | |
| 9. Thread tension | 19. Control box | |
| 10. Detecting roller | 20. Serial port | |

CONTROL BOX

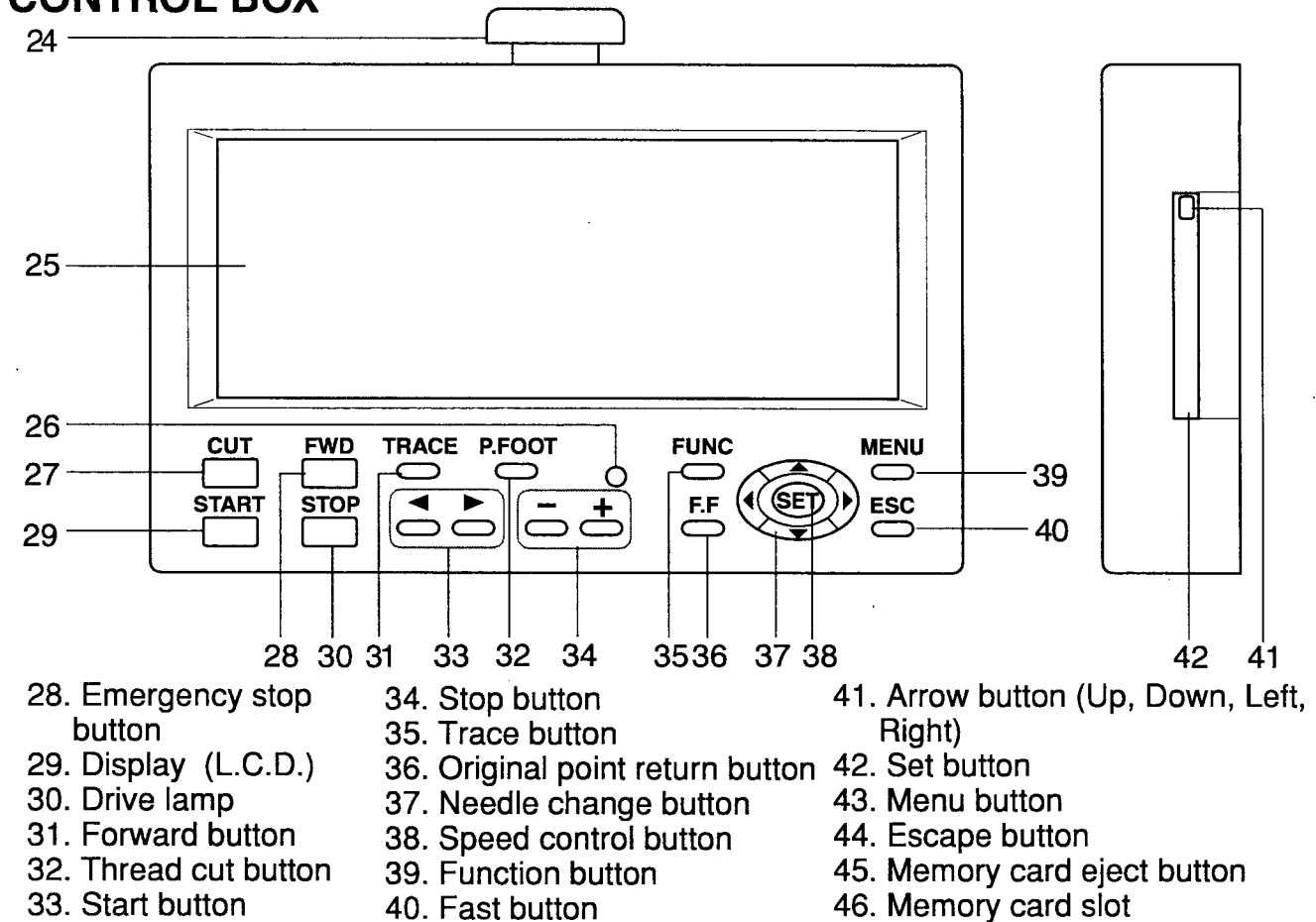

BOBBIN WINDING (Option)

- 47. Upper Thread guide
- 48. Thread stand pin
- 49. Thread stand felt
- 50. Thread guide
- 51. Thread tension
- 52. Spindle
- 53. Lever

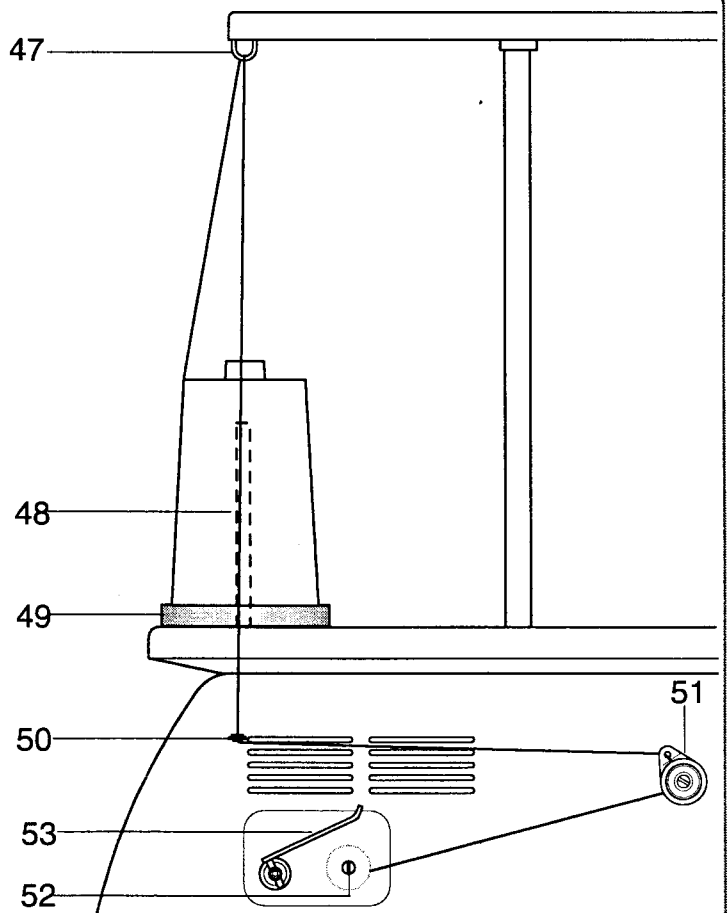

HOW TO READ THESE INSTRUCTIONS

3-3

The instructions in this manual have been formatted as follows:

Written instructions will be provided on the left side of the page while graphics depicting the necessary steps are provided on the right.

Graphics on the far right will show the display after performing the steps indicated.

 **CAUTION: To prevent accidents.**
This will appear for items related to your safety.

 **CAUTION: To avoid problems.**
This will appear for items related to potential problems.

Order of operation

1. When the machine is stopped, Press the **MENU**.

A Words marked with a "*" are explained in "EMBROIDERY TERMS" at the end of this instruction manual.

2. Select desired *menu with .

3. Press **SET** to show the selected menu.

Press **ESC** to return to the previous display.  3-3

Indicates supplementary explanation regarding a given operation or action.

This indicates an additional explanation on an operation elsewhere in the manual for more detail.

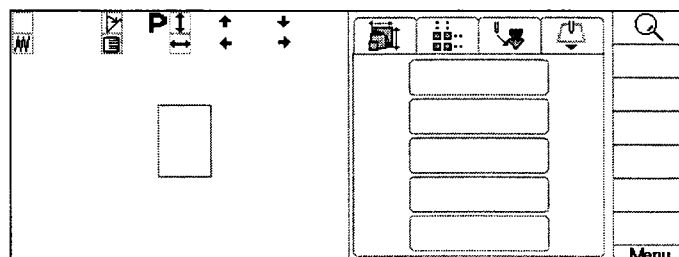
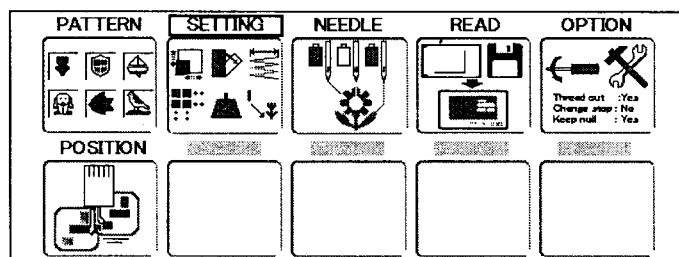
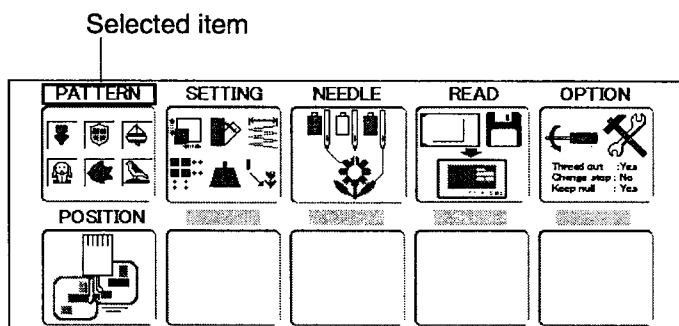

Operation key

 In the order of operation, this denotes that the indicated keypress will cause the display to change.

Below is a list of possible messages that may appear while operating the machine, along with an brief explanation and suggested actions to take as a result.

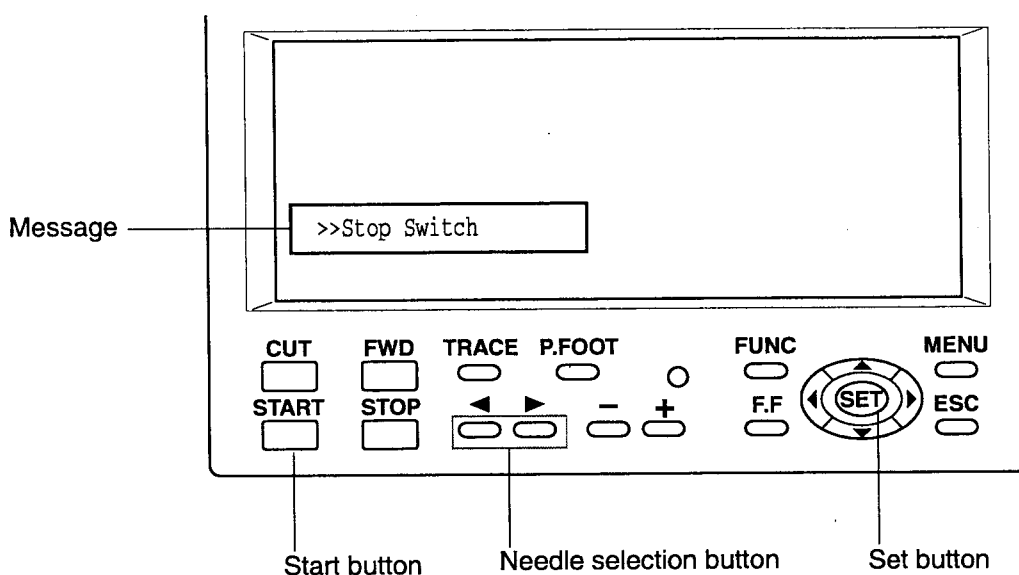

CAUTION: To prevent accidents.
The embroidery frame may move. Please keep hands clear for your safety.

MESSAGE	EXPLANATION	OPERATION	PAGE
A Place to oil B	Designated letter on the display is due to be lubricated.	Lubricate the location indicated by A or B. Refer to the indicated page in this manual then press the "ENTER" button.	23-1
Cleaning of rotary hook Cleaning of thread cut knife	Clean the rotary hook and the thread cutting knife.	Clean with instruction in the reference page then press the "ENTER" button.	23-2
Frame move !	Frame will move to recognize the actual frame position.	When you press the "ENTER" button, the embroidery frame will move and return to the previous position.	3-5
>>Stop Switch	The machine is stopped because the stop button was pressed while embroidering the design.	Press the "START" button to resume sewing.	
>>End	The machine is stopped because it has finished the design.	If you wish to sew design again, please newly hooped item on machine & press "START".	
>>Change Stop	Machine stopped, because you used "Stop at color change point" function.	When you press the "START" button, the machine will select the next color and resume embroidering automatically.	
>>Color ?	Machine stopped because the next color has not been selected.	Please select next needle number by "Needle selection" button then press the "START".	
>>Thread Break	Machine stopped, because upper or bobbin thread broken.	Please thread upper thread or check bobbin thread then press "START" button to resume sewing.	
>>Trace end	The machine is stopped because it has finished with the design trace.	Press the "START" button if OK.	6-4 7-C

● How to turn on the machine

1. Connect the power cord to the inlet on the right side of the machine.

2. Connect the power plug to an electrical outlet.

3. Turn on the power switch.

Please confirm the emergency stop button has been released.
Push the power switch firmly so it will remain on.

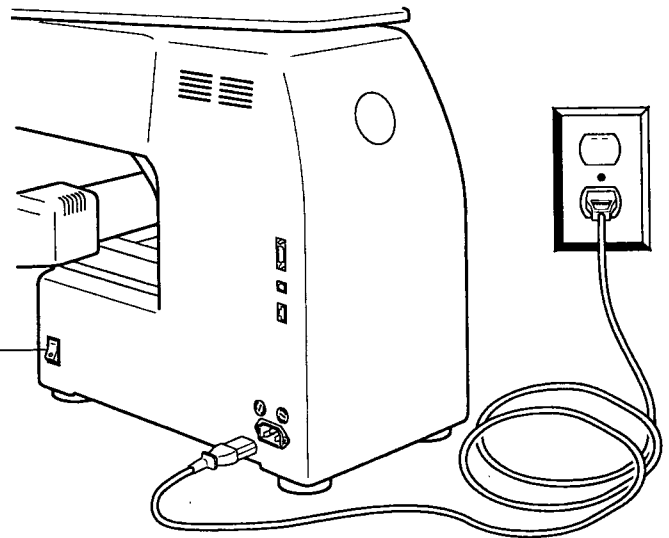

CAUTION: To prevent accidents.
The embroidery frame and carriage will move.
Please keep hands clear for your safety.

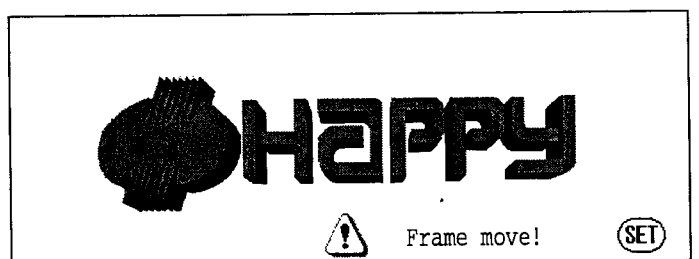

4. Press the **SET** button.
After the carriage and frame move slightly, the embroidery frame will return to the previous position automatically.

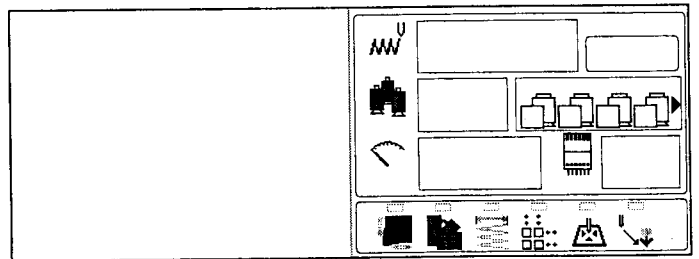

To disconnect, switch the power switch to the off position, then remove plug from outlet.

DANGER: To reduce the risk of electric shock.
Never leave the machine unattended when plugged in.
Always unplug this machine from the electrical outlet immediately after use and before performing any maintenance on it.

WARNING: To reduce the risk of burns, fire, electric shock, or injury to persons.
Do not unplug by pulling on cord. To unplug, grasp the plug, not the cord.

● Display contrast

The contrast can be adjusted by following the procedure below.

1. When the machine stopped, press **(MENU)** and Select "CONTRAST" with .

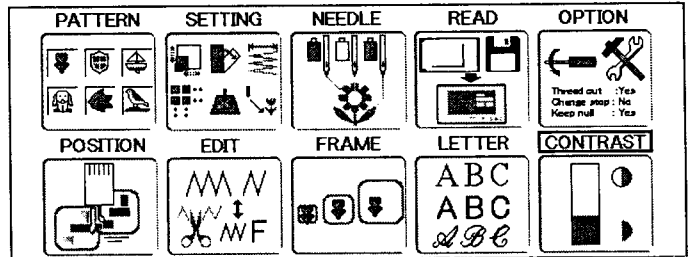

2. Press the **(SET)** button.

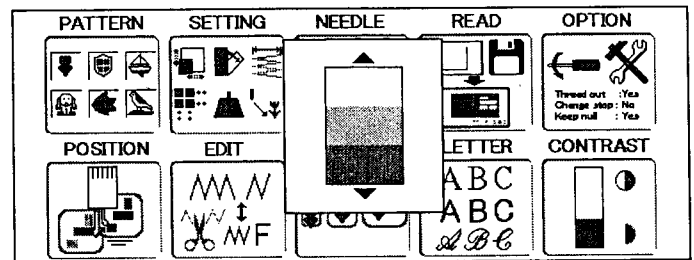

3. Adjust the contrast as desired by pressing .

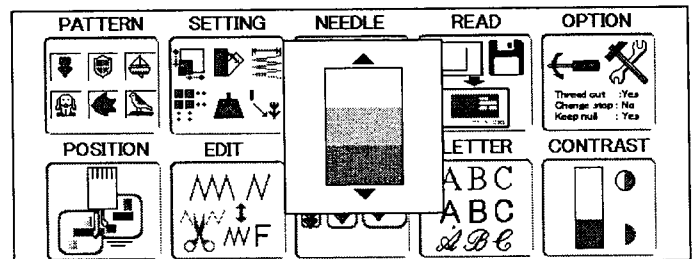

4. Press the **(SET)**.
The setting is fixed.

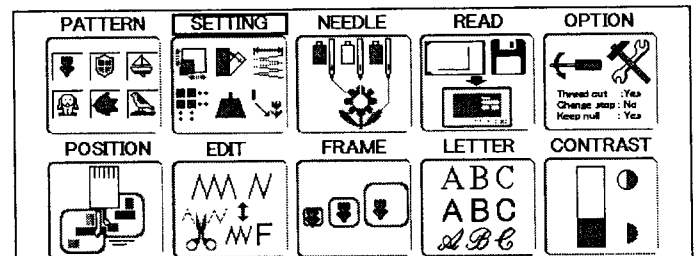

If you Press the **(ESC)** you will return to drive mode.

●Calendar and clock setting

Setting the calendar and clock lets the machine advise when oiling and other maintenance is scheduled to occur.

1. When the machine is stopped, press **(MENU)** and Select "OTHER" with .

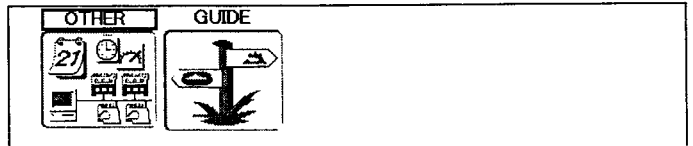

2. Press the **(SET)** button.

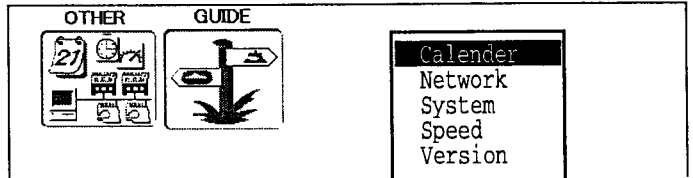

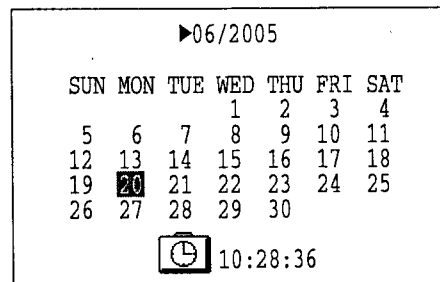

3. Select "Calendar" with  and press **(SET)**.
Current year, month date and time is displayed.

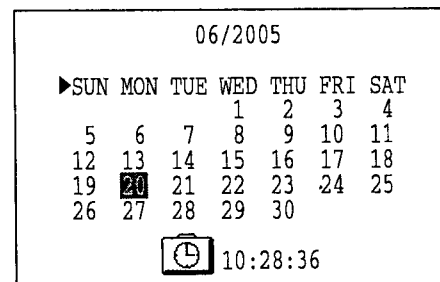

4. Select year, month date and time with up/down of .



5. Press the **(SET)** button.
Press right /left of  to select the setting point, and press up/down of  to select the number of year, month and time. To select the date, press up/down and right /left of .

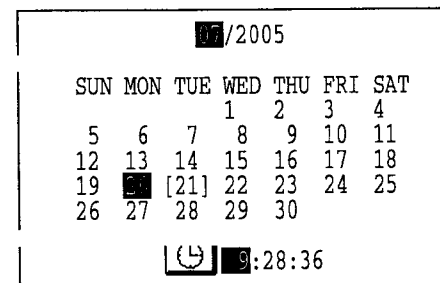

6. Press the **(SET)**.
The date is fixed.

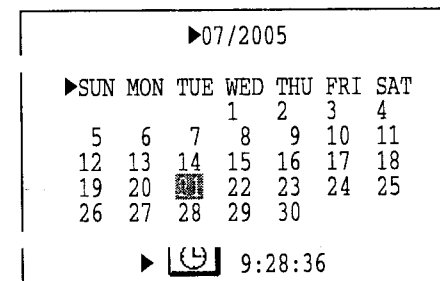

Press **(ESC)** to return to Menu mode.
Press **(ESC)** once again to return to Drive mode.

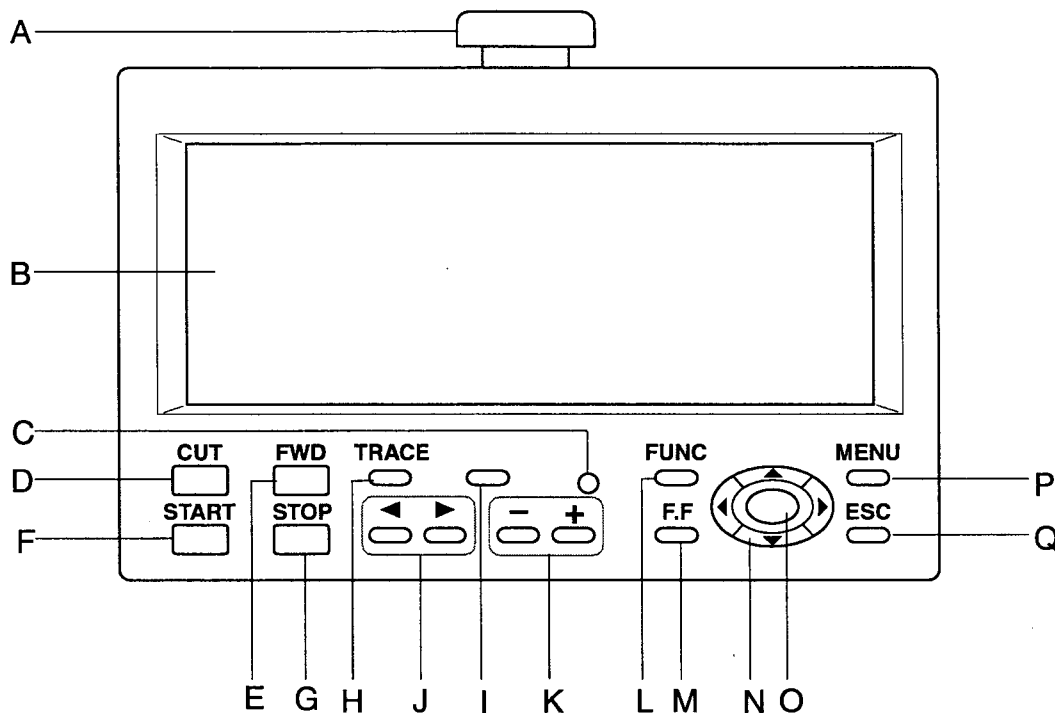

A. Emergency stop button

When pressed, the power is switched off and the machine stops immediately. The emergency button locks when pressed.



To unlock, turn the emergency button to the right (Arrow direction) then release. The button will unlock.

Use this button only for emergency.

B. Display

Shows the embroidery design name, the number of the current needle and other machine generated messages.

C. Drive lamp

Green Machine ready to sew.
Main menu also accessible by pressing MENU, which causes menu to display.

Red Machine has detected an error.
An error number will be shown on the Display. 24-1

Blinking red . Indicates the upper thread has broken or the Bobbin thread has run out.

D. Thread trim button

The Machine will cut the upper and lower thread when this button is pressed.

E. Forward button

Press once The frame moves forward one stitch.

Press continuously ... The frame will move forward continuously.

Keep pressing The button's function locks. The frame will move forward by 1 stitch continuously. Push the "STOP" button to stop it.

When you stop it, push stop button.

Pressing longer still .. Button's function will lock. The frame will move forward by 10 stitches continuously. Push the "STOP" button to stop it.

When you stop it, push stop button.

F. Start button

This button starts the machine. When pressed, while the machine is running, running, the machine will switch to "inching". (Super slow speed)

The Machine will return to the previous speed when button is released.

If you use the inching function for an extended length of time, the stitch quality may be influenced.



CAUTION: To prevent accidents.

If you Press the thread trim button, the needle will penetrate the fabric. Please keep your hands clear for your safety.

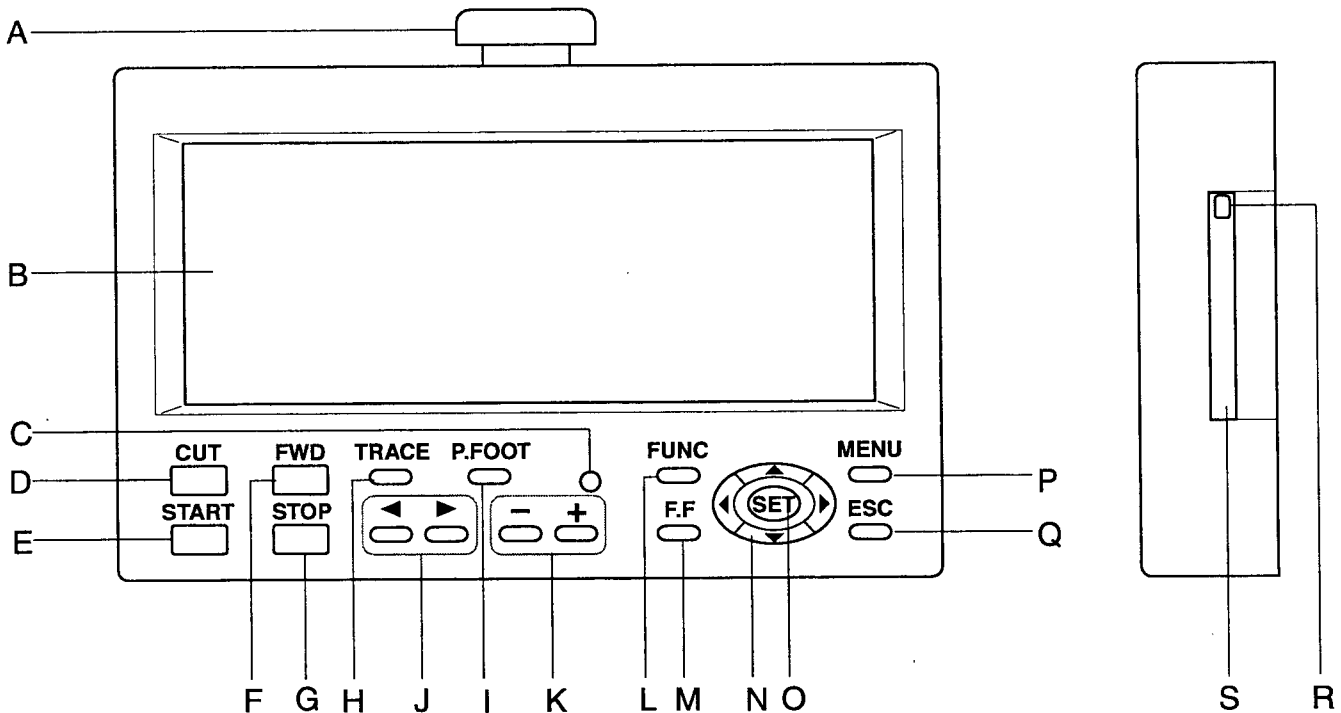

G. Stop button

This stops the machine.

When the STOP button is pressed while the Drive Lamp is blinking (green color), the following will take place depending on the manner pressed:

Press once Frame moves back one stitch.

Press continuously The frame will move backwards continuously.

Keep pressing. The button's function locks. The frame goes back by 1 stitch at a time continuously. Push the stop button again to stop it.

Keep pressing longer still... The button's function locks. The frame goes back by 10 stitches at a time continuously. Push the stop button again to stop it.

H. Trace button

When pressed while at the beginning of design, the embroidery frame moves following the outer edge of the design. This allows you to compare the design size and position against the frame before sewing.

I. Pressure foot button

You can raise or lower the presser foot .

J. Needle change button

Moves the sewing head to the adjacent needle in the direction of the arrows.

K. Speed control button

Press the + button to increase the machine sewing speed and the - button to lower the machine speed. The sewing speed is shown on the display.

L. Function button

Press the function button to execute each function of embroidering.

M. Fast button

When you press this key while pressing frame move key, frame movement speed increases. You can make more slow frame speed in "Machine settings" menu. [P](#) 5-2

N. Arrow button (Up, Down, Left, Right)

The frame moves toward direction of the arrow mark..

In the menu, select each item required by pressing the arrow mark toward the right direction.

You can change direction to opposite side in

" Machine settings" menu. [P](#) 5-1

O. Set button

By pressing Set button, you can execute each function in the menu and other settings.

Indicate target design on LCD panel when non-showing design.

If you press this key and hold, re-display your target design.

P. Menu button

Displays the function menu for the machine settings and the design set-up.

Q. Escape button

Press ESCAPE button when you stop or cancel the settings selected.

R. Memory card eject button

Press this button to take out the memory card.

Do not try to take out the memory card when  is displayed on the LCD display.

S. Memory card insertion slot

PCMCIA card socket for installing the memory cards.

Display example

When beginning an embroidery

Current *Color change number: 0

Stitches of pattern: 5

Memory # of selected pattern: 19:HAPPYE

Name of selected pattern: 19:HAPPYE

Top: [Icon]

Needle number and color: [Icon]

Color change stop: [Icon]

Frame out: [Icon]

Currently-selected needle: [Icon]

Number of maximum repetitions set: 600

Lamp above icon blinks when each function (Scale, Angle /Convert, Width, Repeat, Auto origin and Off set) is set.

While embroidering

+cursor indicates the position of actual stitch point.

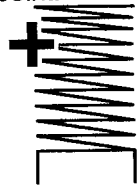

Drawing of next 100 stitch will be shown.

The embroidered part and the next embroidering part will be colored.

Pointer: [Arrow]

Color change number sewn up to now: 2653

Number of stitches sewn up to now: 3

Shift to left when color change: [Icon]

If a needle number is not assigned to a Color change number, the default color will be assigned automatically.

Sewing starts after outline of entire pattern is displayed if sewing is started from "Top" position.

"+" cursor indicates the position of actual stitch point. In the display, pattern is filled with color reflecting sewing progress.

The part which has not embroidered will be shown in outline.

Stitch speed: [Icon]

Machine stopped during embroidering

Status: [Icon]

Normal cap frame: This icon shows that the drive frame is set for low profile cap sewing.

Wide cap frame: This icon shows that cap system is set for wide cap field sewing.

Display if the machine has no design in memory

Top: [Icon]

This indicates that the machine is ready to start sewing from the "top" memory position of the pattern.

Frame out: [Icon]

This indicates that a frame out is occurring.

Display when manually moving the hoop

- Size of pattern
- Height
 - Width
 - ↑ Size between start point and the top of pattern
 - ↓ Size between start point and the bottom of pattern
 - Size between start point and the extreme right of pattern
 - ← Size between start point and the extreme left of pattern

X: -234.5 Y: 123.8

X-distance moved

Y-distance moved (Indicates X and Y distance from origin point)

The following functions are performed by in the drive menu.

Top 9-4

This causes frame to return to the top of the pattern.

The  lights if you perform this function while in the middle of a design.

If this function is performed again, the action will be cancelled.

The  light will turn off. The frame will then return to the previous position it was previously stopped.

Center 9-4

Moves the embroidery frame to the center automatically.

Original point return button

The frame returns to *original point of pattern, and position to start sewing returns to top of pattern data.

Position 9-3

When sewing is interrupted in the middle of a design, this returns the frame to current sewing position regardless of where frame may have been moved with the arrow keys after interrupt.

0 Set (Registration of original point)

This enables to set original point manually.

Normally original point is registered automatically to the first stitch of the pattern data.

Needle Jump, Needle Drive

In this mode, machine will not sew.

Log-in, Log-out

Log-in is for the use of networking between the machine and PC.

Log-out is for disconnecting the machine from the network between PC.

Refer to the Network software instruction which correspond to this machine.

Turn-off



This will be used for turn off the machine when machine is networking.

Refer to the Network software instruction which correspond to this machine.

1. When the machine is stopped, press .
The drive menu will be shown.

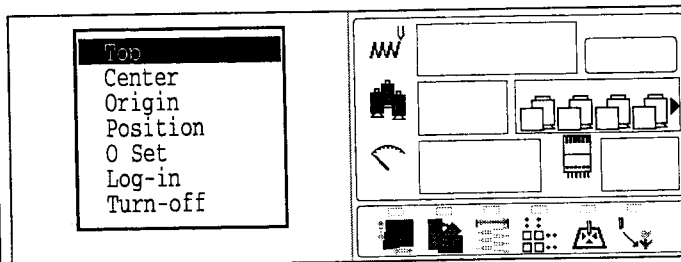
 **CAUTION: To prevent accidents.**
The embroidery frame and carriage will move.
Please keep hands clear for your safety.



2. Select the desired function with  and press .

Drive menu will be cleared after execution of selected function.

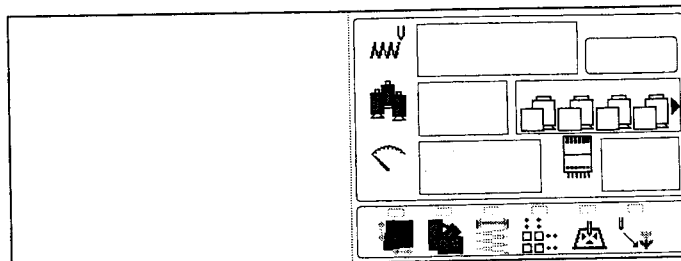

MENU

The diagram below describes the layout functions accessed from the main menu.

The main menu is accessed by pressing **(MENU)**.

From here, any function can

then be selected with the up and down .

Pressing **(SET)** enters your choice.

If you Press **(ESC)** from any point in the Menu mode, you will change to Drive mode.

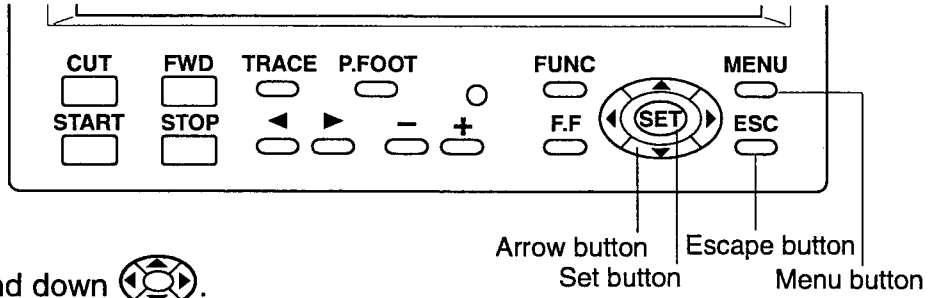

 Explanation page

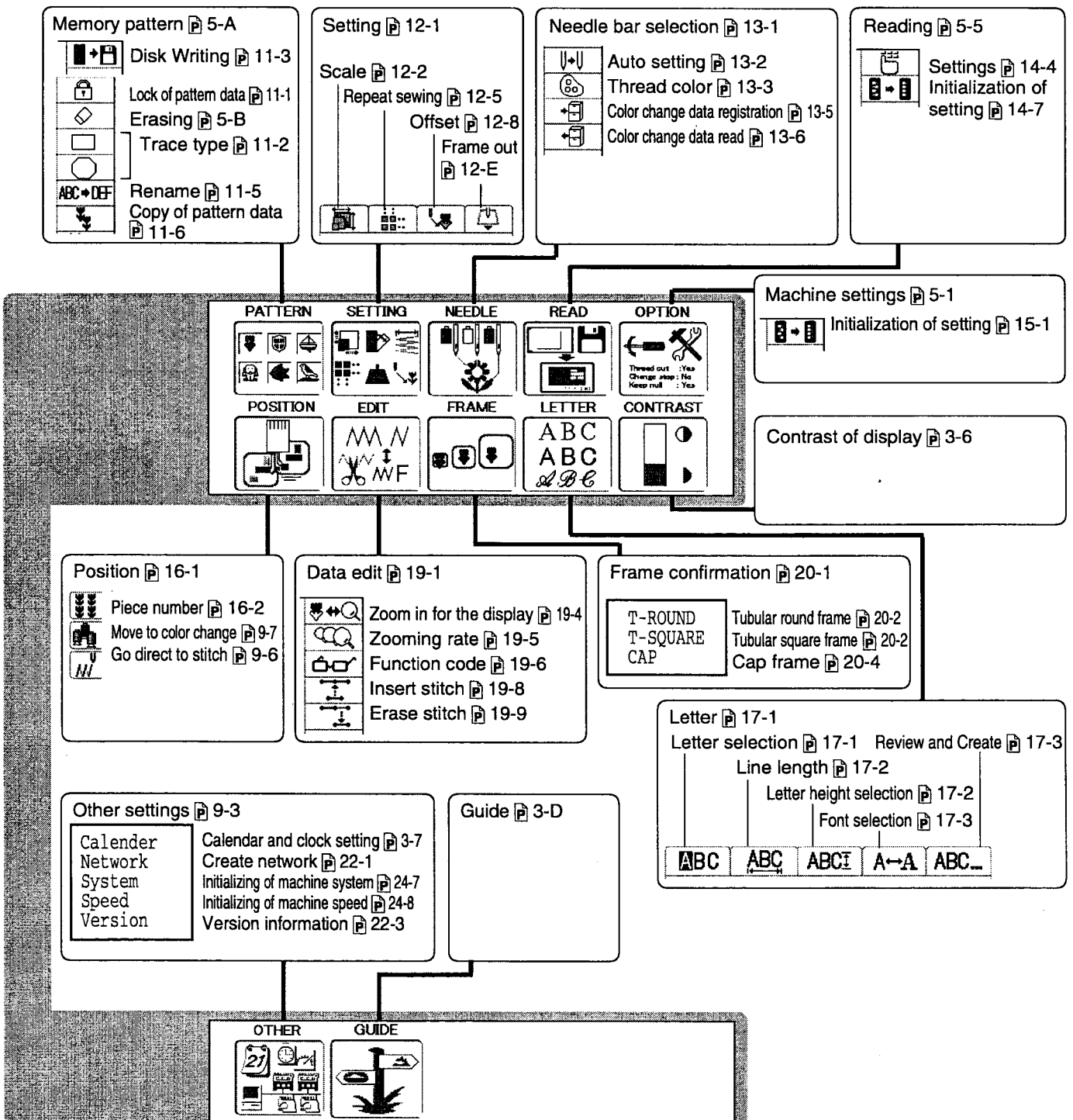

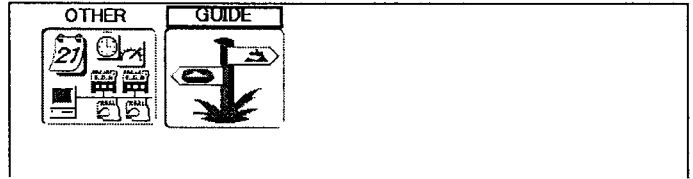

The GUIDE offers tips and step-by-step help for embroidering with the machine. In each stage of embroidery operation there is an easy to follow guide available.

1. When the machine is stopped, press **(MENU)** and Select "GUIDE" with .



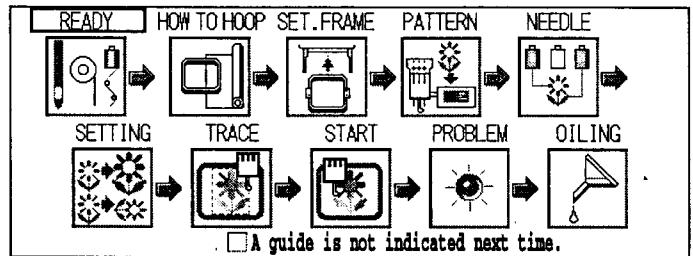

2. Press the **(SET)** button.

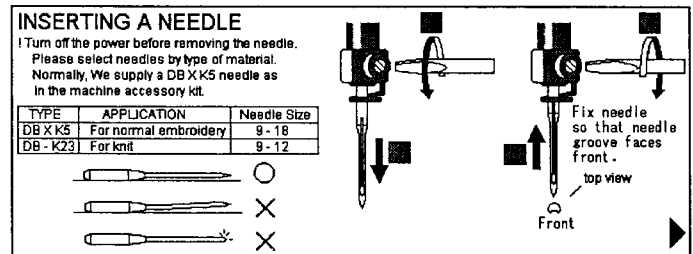

3. Select desired item with  and press **(SET)**.



4. When  or  is shown in the right lower portion of the display, you can move to next page by pressing .

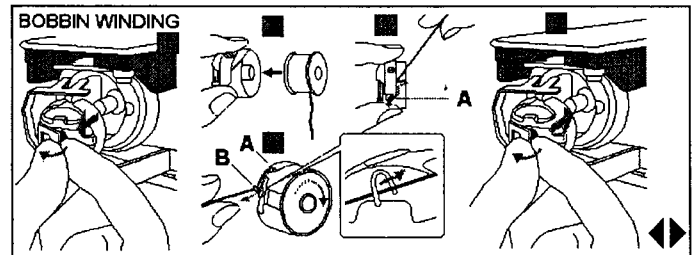

5. Press the **(ESC)**.
You will return to the guide menu.

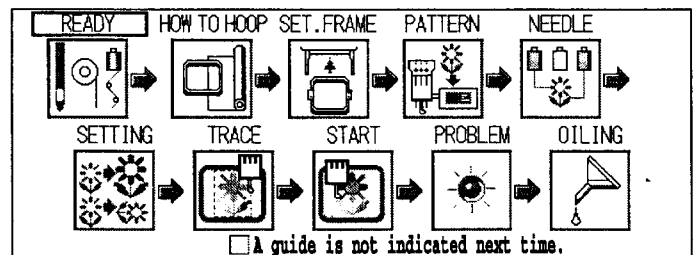

Press **(ESC)** to return to Menu mode.
Press **(ESC)** once again to return to Drive mode.

●Opening "GUIDE" menu indication

Machine will indicate "GUIDE" menu automatically when turn on the machine.

If you do not need "GUIDE" menu when turn on the machine every time, you can create as following.

Also you can select in "OPTION" menu. 5-2

1. When the machine is stopped, press **(MENU)** and Select "GUIDE" with .

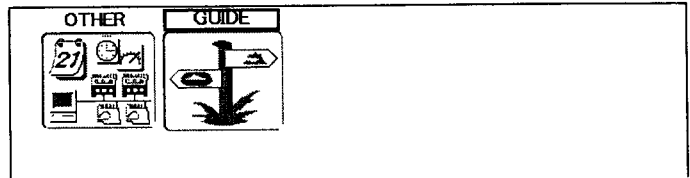

2. Press the **(SET)** butto.

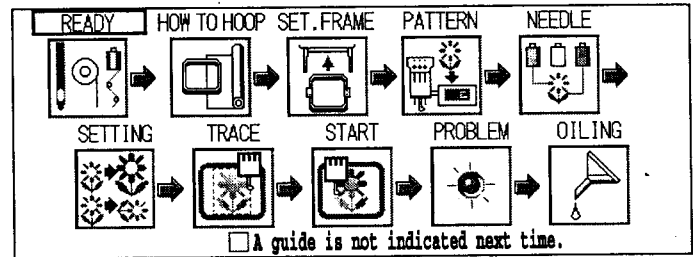

3. Select "A guide is not indicate next time." by .

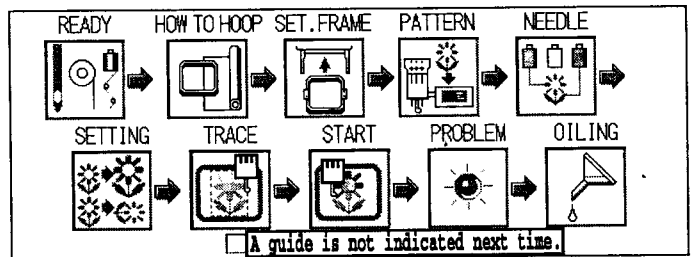

4. Press **(SET)** for change your selection.

- Indicate when turn on the machine next time.
- Not indicate when turn on the machine next time.

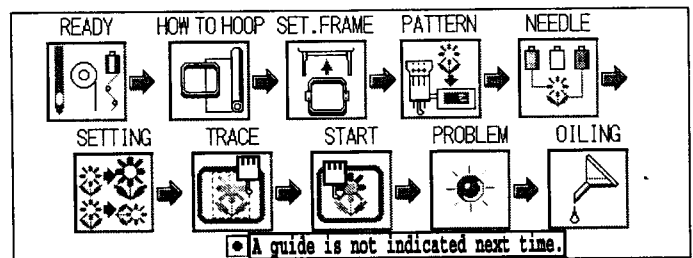

Press **(ESC)** to return to Menu mode.
Press **(ESC)** once again to return to Drive mode.

INSERTING A NEEDLE

4-1

Select a needle of the right type. See the following "SELECT THREADS".

CAUTION: To prevent accidents.
Turn off the power before removing the needle.

1. Loosen the needle clamp screw slightly with the screwdriver.
2. Remove the needle.
3. Insert a new needle into the needle clamp with push it up as far as it will go keeping the slotted side of the needle in front.
4. Tighten the needle clamp screw with the screwdriver.

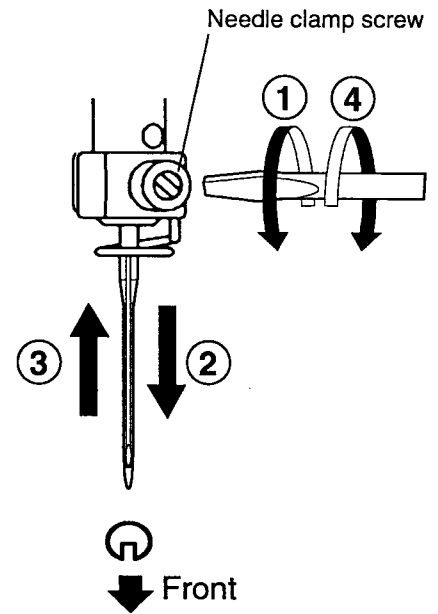

- A. Do not use a bent or blunt needle.
Place the needle on a flat surface and check for straightness.

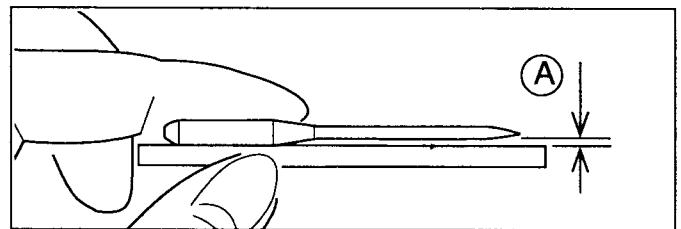

About needle

Please select needles by type of material .

Normally, We supply a DB X K5 needle as in the machine accessory kit.

TYPE	APPLICATION	Needle Size
DB X K5	For normal embroidery	9 ~ 18
DB - K23	For knit	9 ~ 12

Relation of needle and upper thread

Please select type of needle and upper thread by flowing list.

Size		Relation of needle and upper thread			
Organ	German	Cotton #	Silk	Polyester	Rayon
# 8	# 60	100 ~ 130	140 ~ 160	150 ~ 200	50 ~ 70
9	65	70 ~ 80	100 ~ 120	130 ~ 150	70 ~ 100
10	70				
11	75	50 ~ 60	80 ~ 100	100 ~ 130	100 ~ 130
12	80				
13	85	36 ~ 40	60 ~ 70	80 ~ 100	130 ~ 150
14	90				
15	95				
16	100	30 ~ 36	50 ~ 60	60 ~ 80	150 ~ 160
17	105				
18	110	24 ~ 30	40 ~ 50	50 ~ 60	180 ~ 230

Normal embroidery field

► Normal use embroidery needle and upper thread.

Upper thread : Rayon 120 d/2 (120 denier)
 Polyester 120 d/2 (120 denier)

Needle : #11 (DB X K5)

► If the relationship of needle size and thread type is incorrect, it is possible to have any of the following problems.

- Thread break
- Skip stitch (Upper thread does not catch bobbin thread)
- Other stitch quality problem

Backing

Generally, Backing is used for hooped embroidery fabric. Knit fabrics particularly require the use of embroidery backings.

Embroidery backings will allow the hoop to move the fabric more accurately, creating a more beautiful embroidery.

Select backing type

Choose the thickness and number of sheets by the type of material and embroidery condition. Generally, you should consider the following items.

- Embroidery stitch quality
- Contraction or compression of fabric caused by sewing, etc.
- Stiffness of fabric

■ In case, if you sew lace and leather, you may not need backing sheet.

Example of using a backing

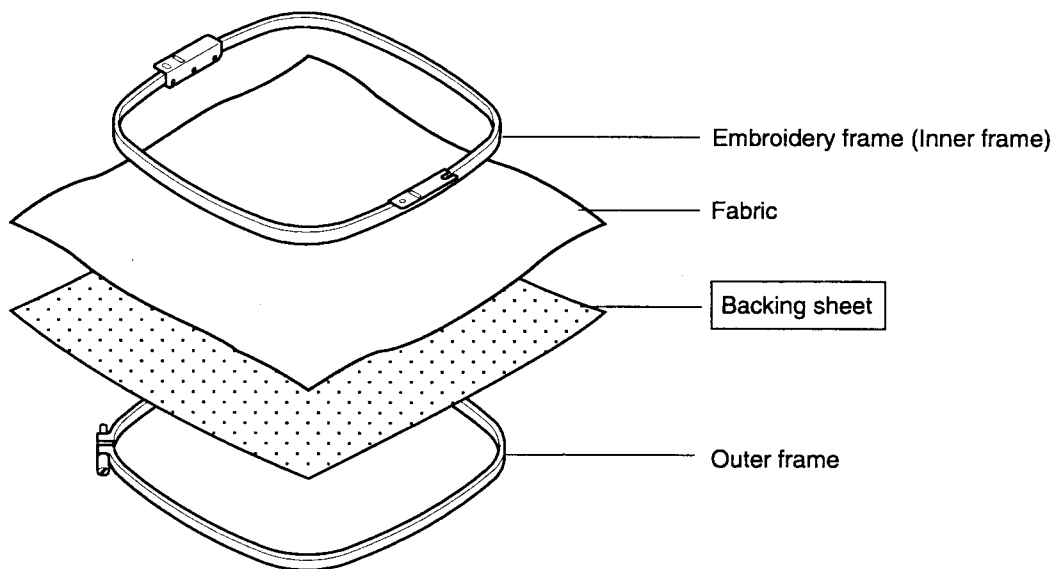

● Winding the bobbin

Thread the bobbin winder as shown below:

1. Upper Thread guide
2. Thread guide
3. Thread tension – Be sure to thread through the small eye before going between the disks.
4. Bobbin (Place the bobbin on the bobbin winder spindle.)
5. Press the limit lever as indicated by the arrow to start the winder. The lever stops the winder automatically after the winding is complete.

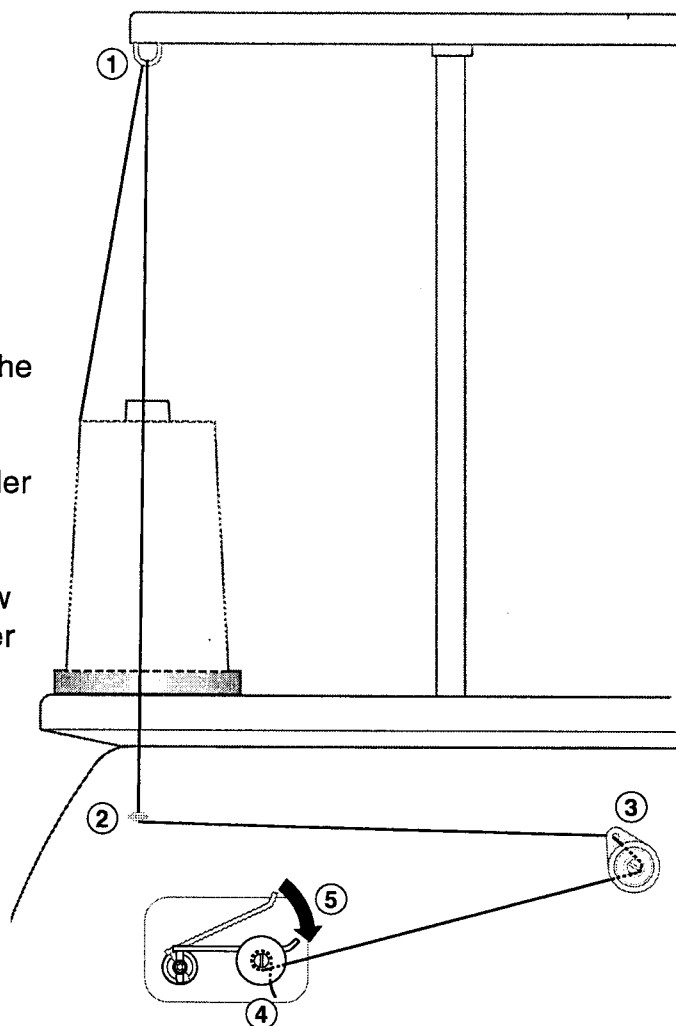

Tension

When adjusting bobbin winder tension:

- Ensure thread winds evenly on bobbin as shown.

Confirm that the bobbin is wound properly..

- Keep the tension constant while winding.

Tighten thread tension if thread winds too loosely.

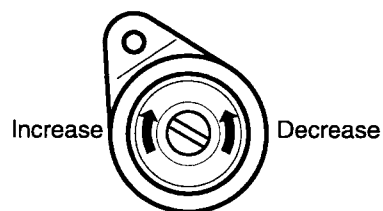

⚠ CAUTION: To prevent accidents.
Please watch out for the point of the rotary hook when you replace the bobbin.

● Removing the bobbin

1. Open hook cover (A) to front.
2. Grasp bobbin case latch (B) and withdraw bobbin case from hook taking care not to damage the thread keeper.

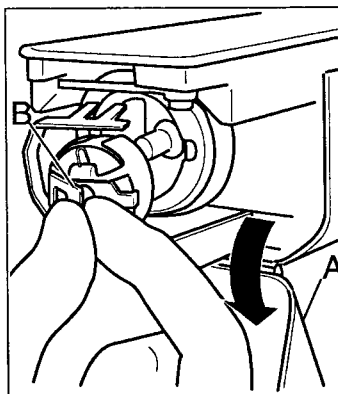

● Inserting the bobbin

1. Hold the bobbin case in left hand. Hold the bobbin in your right hand with thread on top leading from left to right.
2. Insert bobbin in case and draw thread up into slot in case.
3. Draw thread under tension spring (A) and wind into guide coil (B). The bobbin should turn clockwise in the case when the thread is pulled.

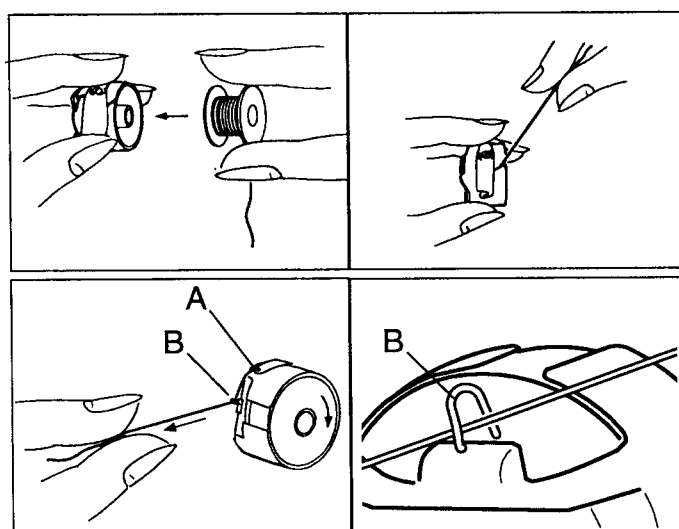

● Adjusting bobbin thread tension

1. Hold bobbin thread and jerk upward approx. an inch. Thread should unspool further approx. the same amount.
2. The screw on the tension spring is for adjusting bobbin tension. This adjustment is very delicate. Please turn the screw only a small amount. Only 1/8 of a turn maximum.

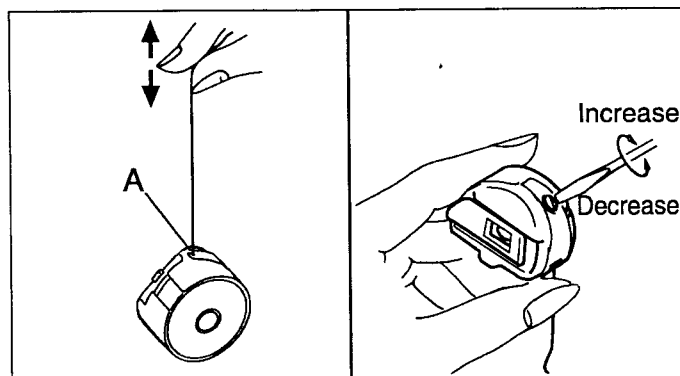

● Inserting the bobbin case

1. After threading bobbin in case, open bobbin case latch (A), grasping it in fingers as shown. Slip bobbin and case on stud of rotary hook body, and press in securely. Release bobbin case latch. Press the bobbin case in to be sure it is fully seated.
2. Close hook cover.

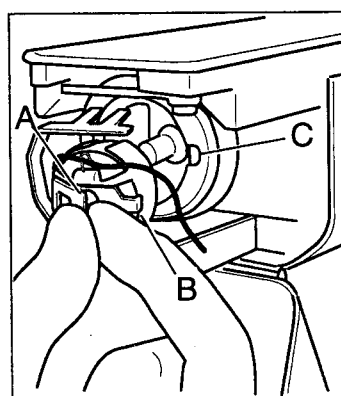

■ The attached bobbin case is available only for this machine. Thread may be caught in thread guide coil if other types are used.

● How to thread upper thread

Pass upper threads in order according to the figure:

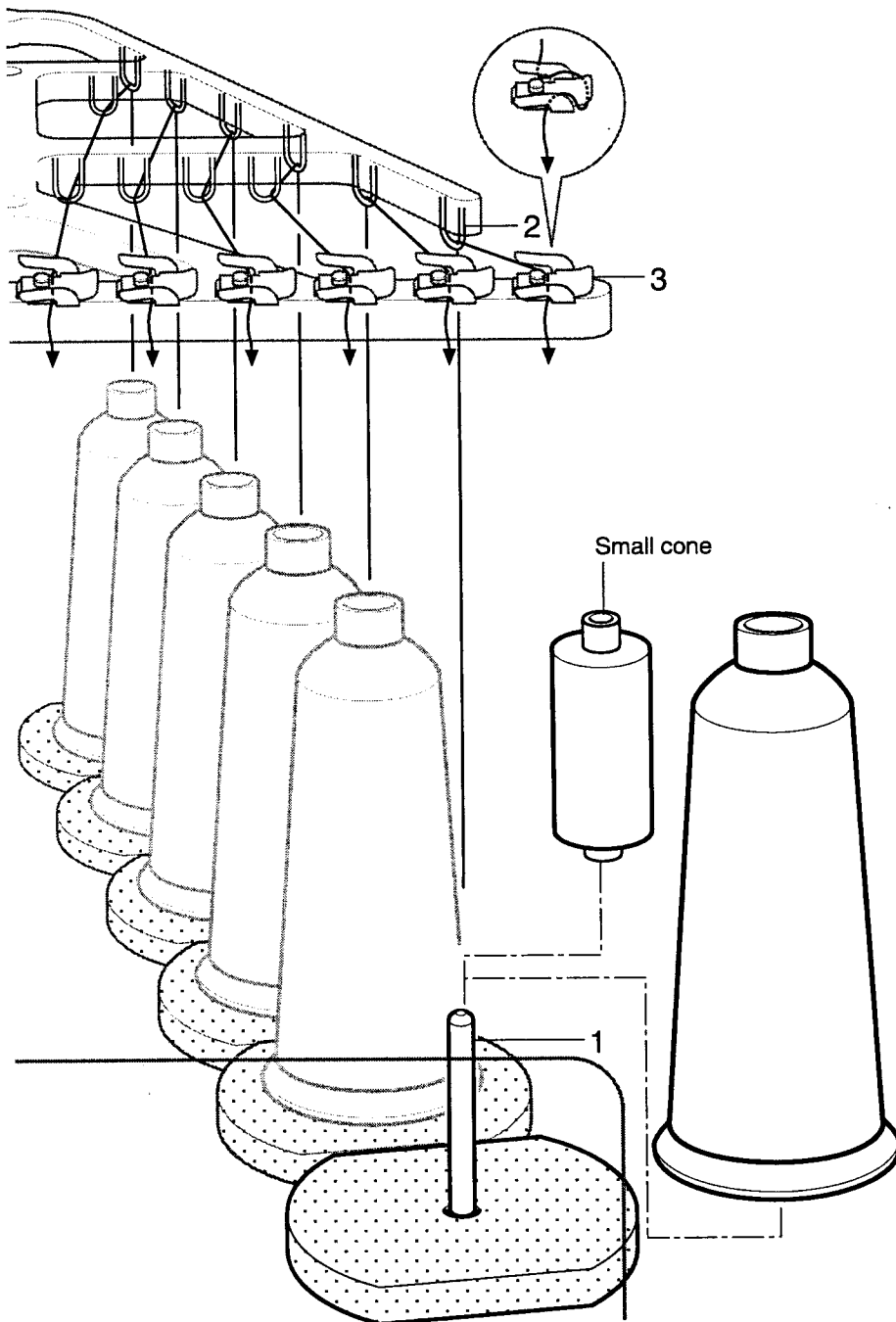

1. Thread stand

Set thread cone on the stand.
Small cones can also be used as shown.

2. Thread guide

Thread through the thread guide above each thread cone.

3. Upper rectifier

Continued next page

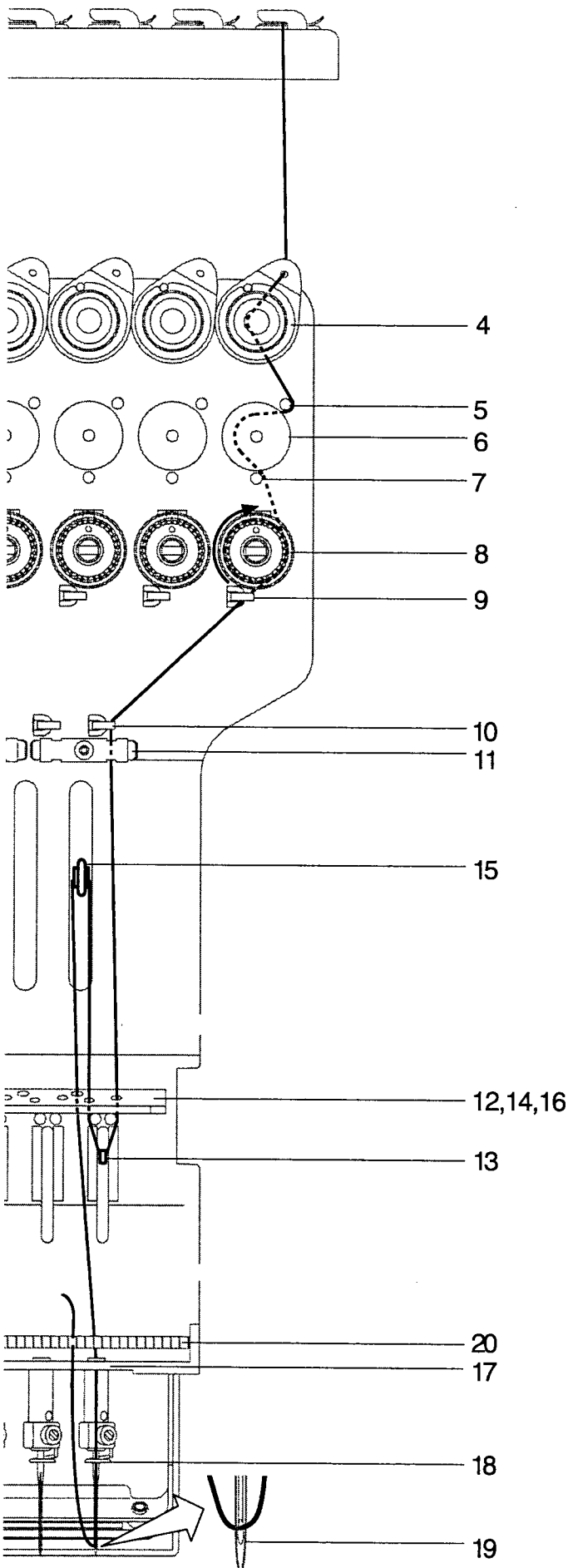

4. Minor thread tension
5. Guide pin upper
6. Detecting roller
7. Guide pin lower
8. Thread tension
Wind upper threads one time around rotary tension disc clock-wise.
9. Upper thread guide
10. Lower thread guide
11. Lower rectifier
12. Thread guide plate upper
13. Thread adjusting spring
14. Thread guide plate upper
15. Take-up lever
16. Thread guide plate upper
17. Thread guide plate lower
18. Needle bar thread guide
19. Needle
Thread from front side of needle.
Pull upper threads slowly and see that the detecting roller moves smoothly by pulling the thread downward as much as possible.
20. Thread holding spring
Push thread into spring.

CAUTION: To prevent accidents.
Please be careful of the sharp point of the needles when threading upper threads through the needle.

MACHINE SETTINGS

5-1

Before embroidering, check the basic settings of the machine.

Be sure to set #14 (232C speed) if setting up a PC serial connection.

The rest of the settings can be left at default values (as indicated by underline below).

No. Display	Setting <small>Default is underlined</small>	Contents
1 TRD. break back	<u>Yes</u> No	On thread breaks, this causes sewing position & frame to move backwards by several stitches before the detected break before stopping.
2 All head mending	Yes <u>No</u>	The machine mends threads only on heads with detected thread break. The machine mends threads for all heads irrespective of thread
3 Width data limit	1 - <u>13</u> mm (13=12.7)	When stitch length exceeds this length, the machine divides it by this jump length and creates multiple movements. Width data limit becomes 12.7mm only when setting value is set to 13. Please use a smaller number when you use thick and heavy material.
4 Quick start mode	Yes..... <u>No</u>	If you set to "No", the machine will increase speed slowly. Please select "No." when you have a problem with skipped stitches on the beginning stitch after thread trim. • The machine sews up to 3 stitches slowly after thread cut. • The machine sews up to 5 stitches slowly after thread cut.
5 Auto thread cut	<u>Yes</u> No	This performs automatic thread cut after color change and stop.
6 Cut at jump data	1 ~ 8(<u>3</u>)..... 0.....	When a set number of continuous jumps exists in pattern data, the machine cuts threads before jumping. • Machine trims the thread on setting number of constant jump. • Does not trim.
7 Cut at null jump	<u>Yes</u> No.....	This sets thread cuts before null jumps (isolated jumps with no net movement) • Does trim on empty jump data. • Does not trim on empty jump data.
8 CHG. always cut	Yes..... <u>No</u>	Forces a trim at every color change. • Always thread trim before color change. • If data does not have trim function at color change point, machine does not trim.
9 Length of TRD. cut	Max. Long <u>Normal</u> Short Min.	The machine cuts upper threads to a longer length.
10 Thread back long	Yes..... <u>No</u>	Select long lock stitch. • At time of thread cutfi 1.2mm, At time of startfi 1.6mm • At time of thread cutfi 0.8mm, At time of startfi 1.2mm
11 Slow (mend out)	Yes <u>No</u>	When mending finishes and all heads start to embroider again, machine speed to be decelerated for safety purpose.
12 STR. Lock stitch	<u>Yes</u> No	Adds lock stitch automatically.
13 Width data all	-1.0 ~ 1.0mm <u>0.0</u> mm.....	This is to alter the widths of all satin stitches for all the designs in the memory. • Adjust satin stitch width by selected amount. • Does not adjust width.
14 232C speed	19200 bps <u>38400</u> bps 57600 bps 115200 bps	Please select the Communication speed (baud rate) of the machine's serial port. Adjust the communication speed to the same speed as your PC. If the baud rate is set to a larger amount, the data of the design will be read faster. However, there is a greater potential for error at higher rates.
15 TRD. break detect	Quick <u>Norma</u> Slow Off	Sensitivity selection of the thread break detect sensor. By default it is set to "Normal".
16 Convert cap	<u>Yes</u> No	When you install the cap drive frame on the machine, the machine will convert (rotate) your design automatically.
17 Cap frame type	<u>Normal</u> Wide	When you use normal cap frame. When you use wide cap frame.
18 Revers frame move	Yes <u>No</u>	Frame will be moved in the opposite direction of the arrow key.

MACHINE SETTINGS

5-2

No. Display	Setting <small>Default is underlined></small>	Contents
19 Revers move fast	Yes <u>No</u>	Frame movement will be faster by pressing arrow key. Frame movement will be slow down by using with fast key.
20 Opning GUIDE	<u>Yes</u> No	Machine will indicate "GUIDE" menu automatically when turn on the machine.

1. When the machine is stopped, press **(MENU)** and Select "OPTION" with .

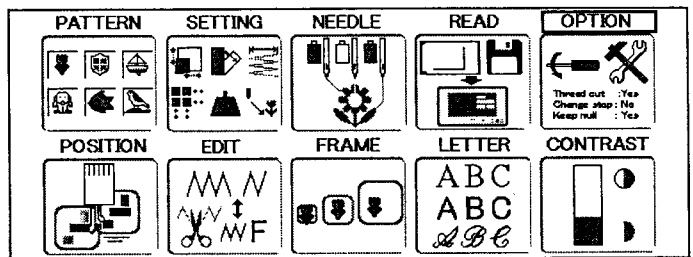

2. Press the **(SET)**.

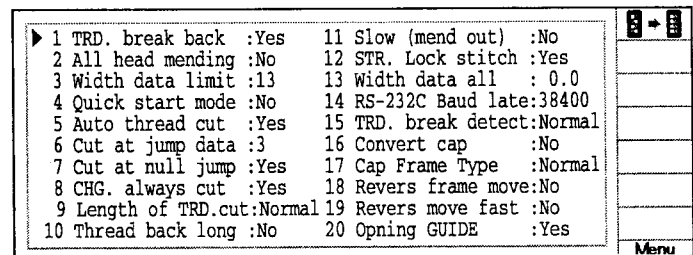

3. Select desired setting item with .

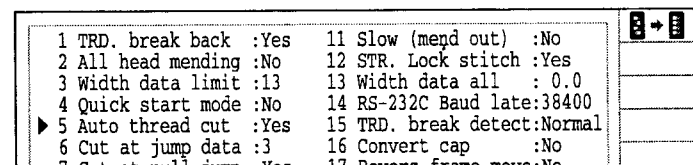

4. Press **(SET)** and press up/down of  to change the setting.

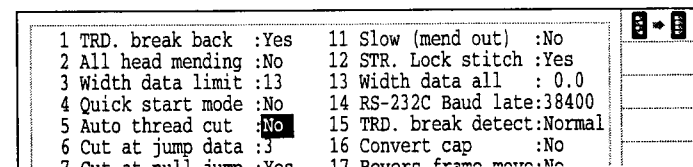

5. Press the **(SET)**.

Each item will be indicated in green if it has changed from its default setting. It will revert to black if setting has returned to default.

Other settings can be changed by following procedures 3 through 5.

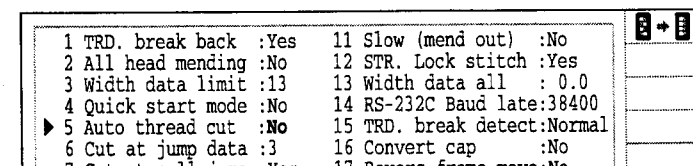

Press **(ESC)** to return to Menu mode.
Press **(ESC)** once again to return to Drive mode.

Detailed explanation of machine settings

13 Width data all

This function adds additional width to all satin stitches in a design.  12-3

This is otherwise set in the "Settings" function, in which case any changes made to the setting from this screen will have no effect.  12-3

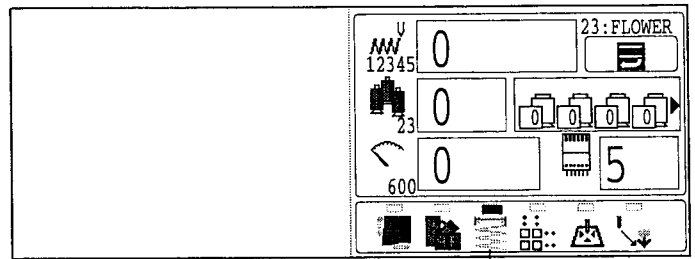

The "Width adjustment" icon will be turn blue.

●Connecting to a PC by Serial or USB connection

This embroidery machine will allow you to read design data from a connected PC.
A Serial cable or a USB cable can be used for the connection.

Serial connection

Connect the serial cable between the serial port (RS-232C) of the machine and the serial port of the PC.



CAUTION: To avoid problems.

Make sure that power source of machine and PC are off when connecting serial cable.

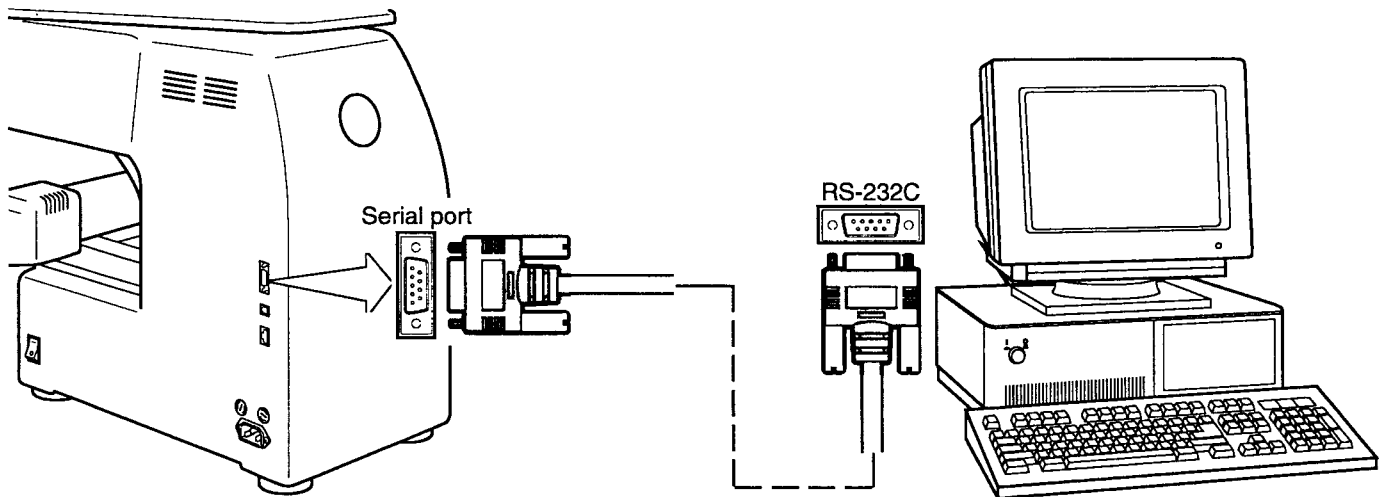

USB connection (based on the USB 1.1, 2.0)

Connect by USB cable between USB port of the machine and USB port of the PC.

When you connect the USB cable, make sure that the machine is powered and set into drive mode (lamp will be green), and that the PC is also turned on.

After recognizing USB in your PC, start-up the "Happy Link".

Please refer to instruction book of "Happy Link" for more precise information.

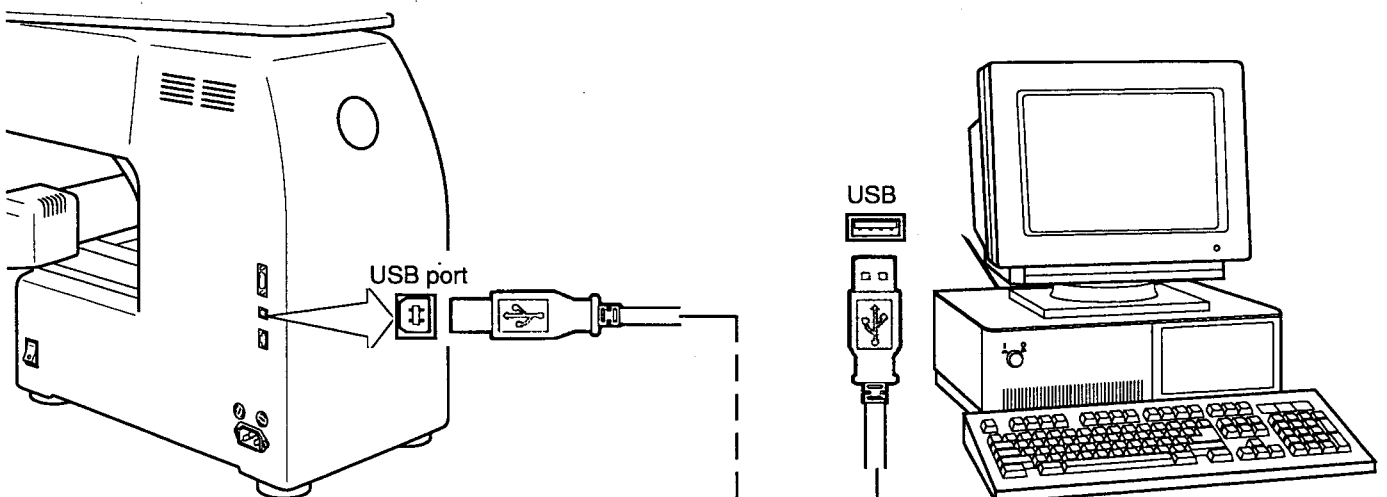

●Reading embroidery pattern data from the PC

Designs can be transferred to the machine along with some functions by using the "Happy Link" software.

Please refer to the "Happy Link" software manual for instructions.

● Reading embroidery pattern data from memory cards

Read the pattern to be embroidered from the memory card.

These types of Memory cards can be used:

This machine is able to read different kinds of memory cards, which are generally used for digital cameras.

- Compact flash card
- Smart media card
- Memory stick
- SD card

■ The capacity of the memory card must be greater than 16MB. This machine will not read 8 Mb memory cards.

■ If you format the memory card with your PC, use FAT format. This machine will not read memory cards formatted to FAT32. This machine will also not read memory cards formatted by other devices such as digital cameras.

■ Please do not create folders or sub-folders in the memory card. This machine will not read designs properly if they are in a folder.

⚠ Note for using Memory Card:

It is only possible to use only memory cards (compact flash card, smart media card, memory stick, SD card) which are inserted into a PCMCIA card adapter.

If you use a LAN or PCMCIA card other than those than noted above, it is possible to damage the machine.

⚠ Handling memory cards and adapters:

Do not bend, drop, disassemble, charge or heat the memory card. Keep away from humidity or direct sunlight.

Inserting memory cards:

1. Insert the memory card into its PCMCIA adapter.
2. Insert the PCMCIA card adapter all the way into the memory card slot of the machine. The Eject button will come out.
3. Read embroidery design data according to following "Memory card reading" in the next section.



Eject Button

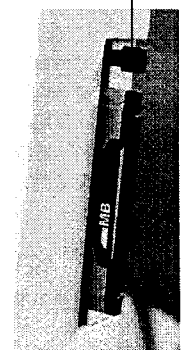

Do Not Remove card

Removing memory cards

1. Check that the "Do Not Remove" icon is not showing and press the eject button. Pull memory card and adapter all the way out.
2. Handle the memory card carefully.

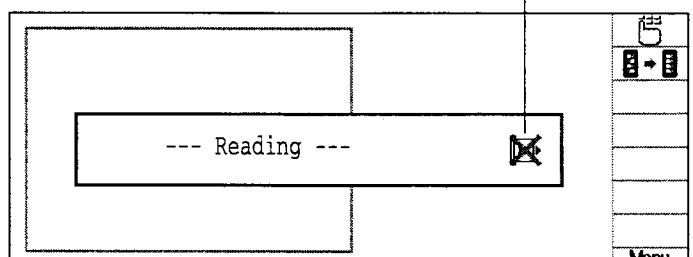

Memory card reading

1. Insert the memory card into the machine as described in "Inserting memory cards".

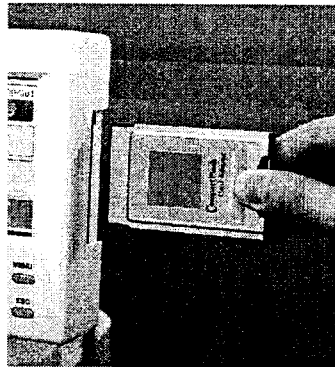

2. When the machine is stopped, press **MENU** and Select "READ" with .

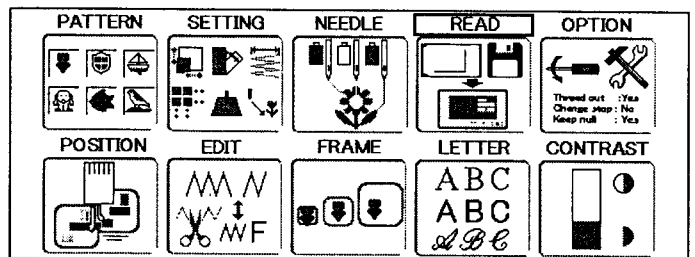

3. Press the **SET**.
Indicates pattern data of the memory card.

 Memory card removal is prohibited
Pattern data in the memory card or machine can be destroyed if you remove the memory card at this time.

Memory card removal is prohibited

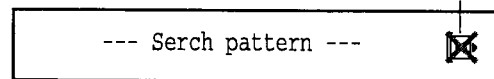

The designs new ID number in the machines memory. Free memory

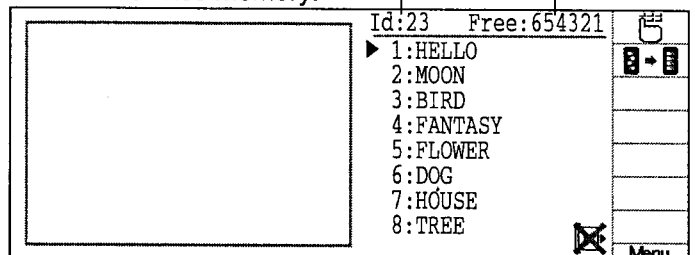

4. Select pattern with .
Before writing, check that there is more remaining space than the number of stitches that are going to be written.
If there are more stitches than remaining space, you may need to delete some designs to make room for the new patterns.

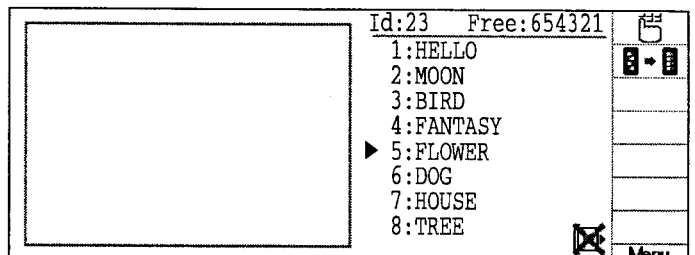

5. Press the **SET**.

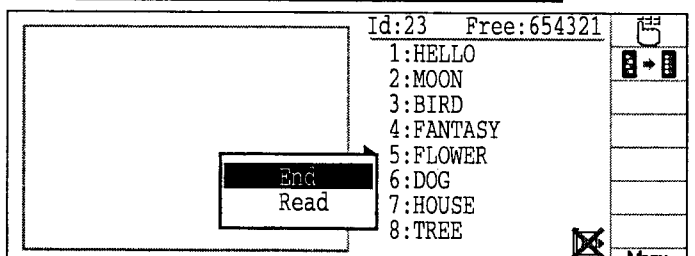
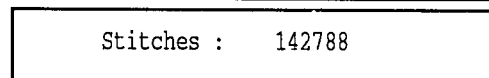
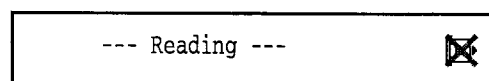

PREPARATION OF PATTERN DATA

5-7

6. Press the **SET** button.
"End" will return you to the menu.

Or, if you wish to read another design,
select "Read" and press **SET**.
Continue to follow the items in step 4.

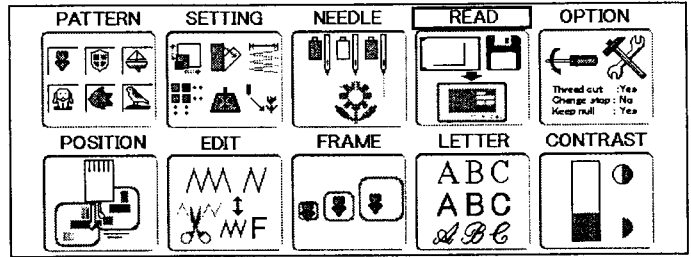

Press **ESC** to return to Menu mode.

PREPARATION OF PATTERN DATA

5-A

● How to select patterns from memory





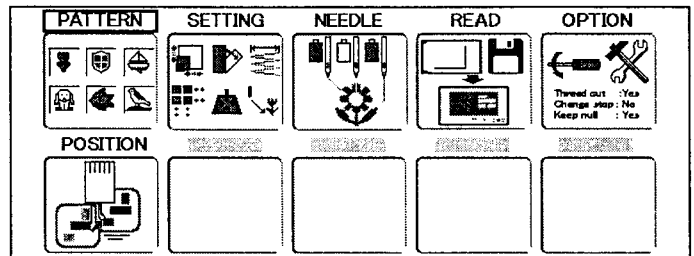



To select an embroidery design previously stored into the machine memory.

1. When the machine is stopped, press **(MENU)** and Select "PATTERN" with .



2. Press the **(SET)**.

The display indicates the current pattern. The left side of display shows the number, name and details for the current pattern.

-  Number of stitches
-  Number of Color change number
-  Height
-  Width
-  Size between start point and the top of pattern
-  Size between start point and the bottom of pattern
-  Size between start point and the extreme right of pattern
-  Size between start point and the extreme left of pattern

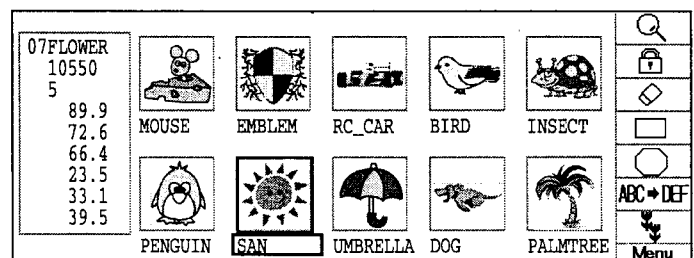

3. Select pattern data with  and press **(SET)**.
This pattern will be selected.

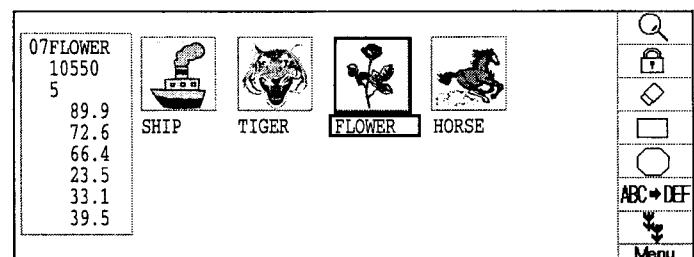

Press **(ESC)** to return to Menu mode.
Press **(ESC)** once again to return to Drive mode.

PREPARATION OF PATTERN DATA

5-B

●Erasing patterns from memory

This is to erase an unnecessary design data from the machine memory.

Pattern data cannot be erased if the lock is set.

1. When the machine is stopped, press **(MENU)** and Select "PATTERN" with .

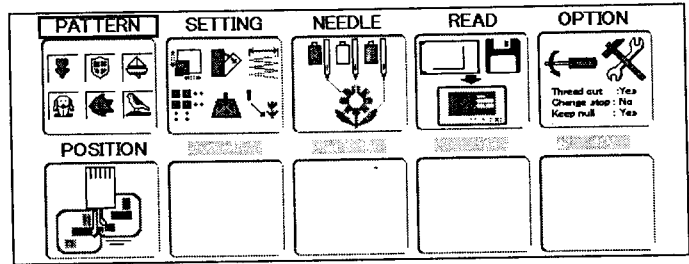

2. Press the **(SET)**.

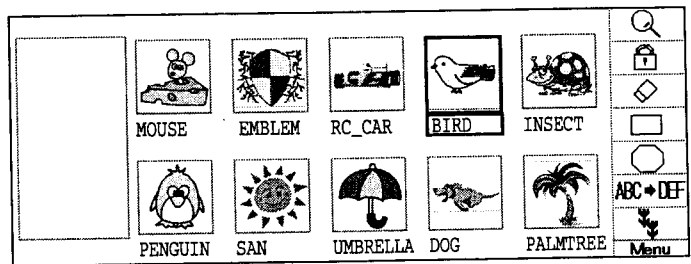

3. Press **(MENU)** and select from right submenu with .

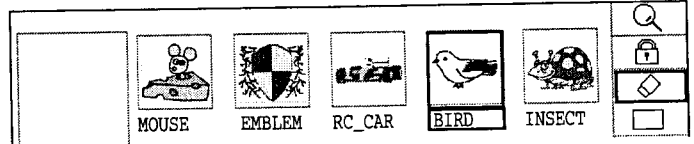

4. Press the **(SET)**.

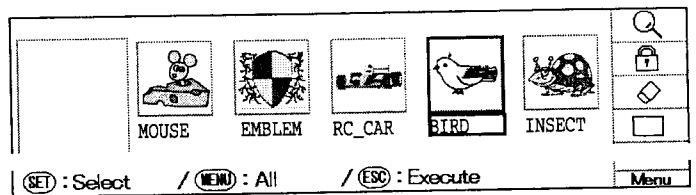

5. Select desired pattern data with .

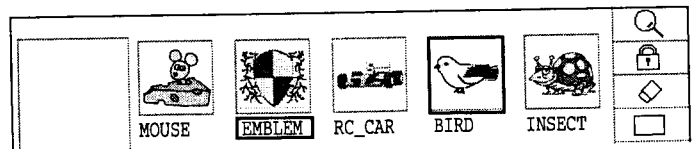

6. Press the **(SET)**.

"[" will appear left of the pattern name.
Make will be cleared by press it again.
To erase the other data, repeat steps 6 and 7.

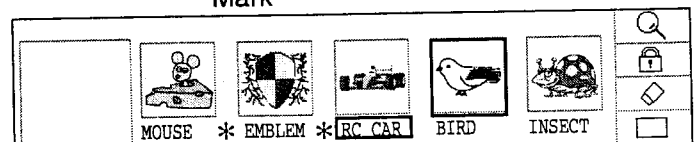
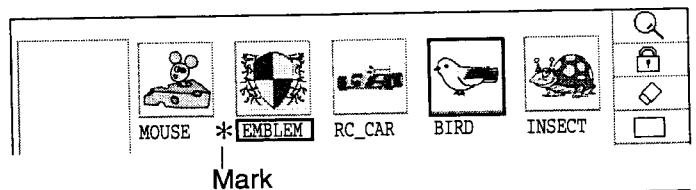

Example : when you selected plural designs

PREPARATION OF PATTERN DATA

5-C

7. Press the **(ESC)**.

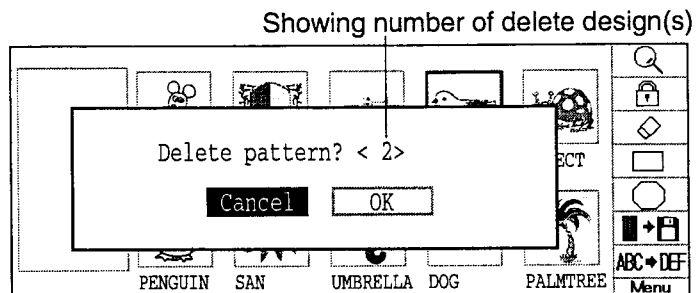

8. Select "OK" with  and push **(SET)** to delete.

The item will be deleted.

To delete other patterns, repeat steps 3 to 8.

Press **(SET)** to cancel the delete.

The display will return to step 2.

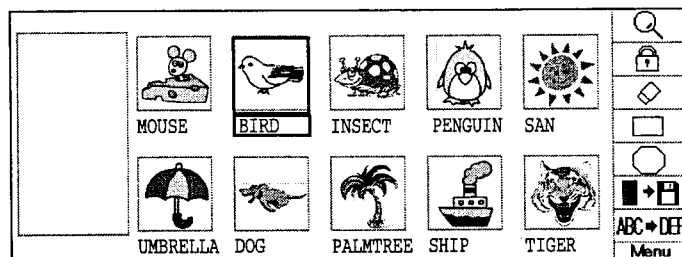

Press **(ESC)** to return to Menu mode.

Press **(ESC)** once again to return to Drive mode.

PREPARATION OF PATTERN DATA

5-D

●Erasing all designs

This deletes all the memory pattern data in the machine at once.

Pattern data cannot be erased if the lock is set.

1. When drive lamp is on with green color, press **(MENU)** and Select "PATTERN" with .

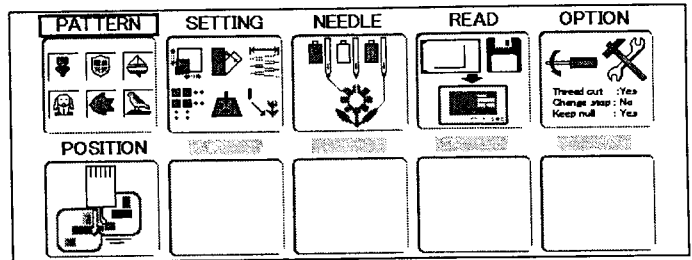

2. Press the **(SET)**.

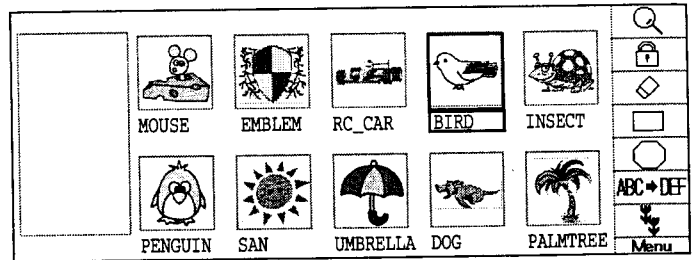

3. Press **(MENU)** and select from right submenu with .

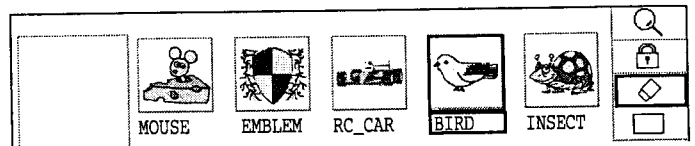

4. Press the **(SET)**.

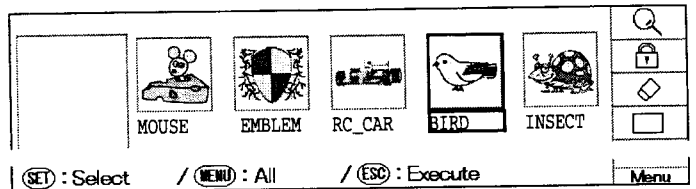

5. Press the **(MENU)**

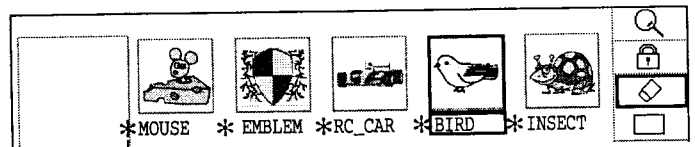

"*" is added to all the memory pattern data.

Showing number of delete design(s)

6. Press the **(ESC)**

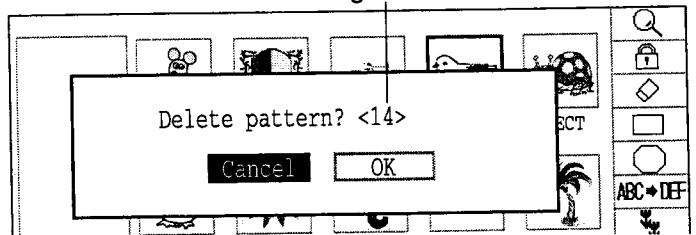

7. Select "OK" with and push **(SET)** to carry out to delete.

All the data will be deleted and the display will return to MENU.

Press **(SET)** to cancel the deletion.
The display will return to step 2.

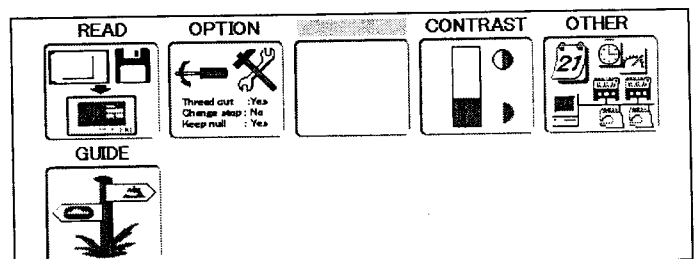

MENU while all the patter data is being erased.

NEEDLE BAR SELECTION

5-E

For each color change in a given pattern, the needle number loaded with the correct color thread is assigned by the operator. When this is set, the machine automatically changes to the programmed needle when the design reaches that point in the course of sewing the design.

You can not setting "NEEDLE" for selected "LOCK" design.

Please release "LOCK" from design. 11-1

1. When the machine is stopped, press and Select "NEEDLE" with .

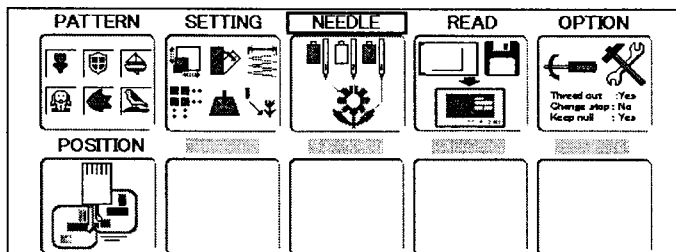

2. Press the .

The left side of the display shows the number, name and details of the current pattern.

- Number of stitches
- Angle
- Convert
- Number of Color change number
- Height
- Width
- Size between start point and the top of pattern
- Size between start point and the bottom of pattern
- Size between start point and the extreme right of pattern
- Size between start point and the extreme left of pattern

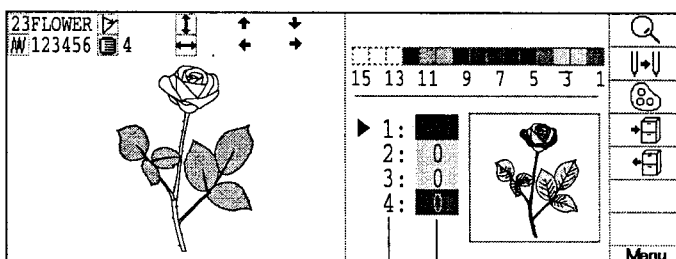

Color change number Needle number

3. Press up/down of to select the color change number.

The current color number is showed in the pattern data display portion.

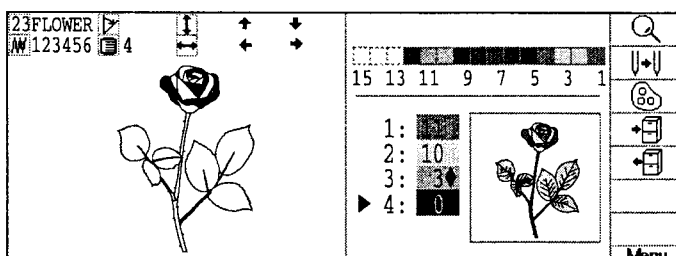

4. Press right /left of to select the needle number.

The setting is fixed.

When is displayed at right side of the needle number, frame out is set. 12-E

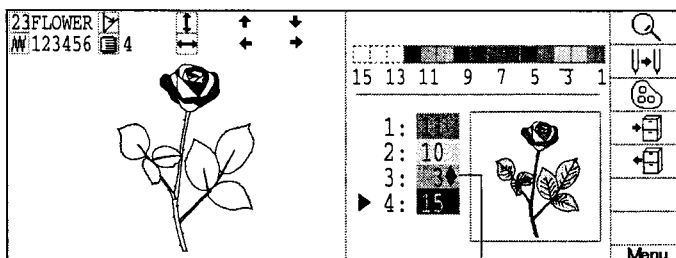

Frame out mark

Press to return to Menu mode.
Press once again to return to Drive mode.

NEEDLE BAR SELECTION

5-F

Color change stop function

When a color change stop is set to a color change number, the machine will stop after it finishes sewing the marked needle number, then following message will be shown:

When you wish to start again, Press the **START** button.

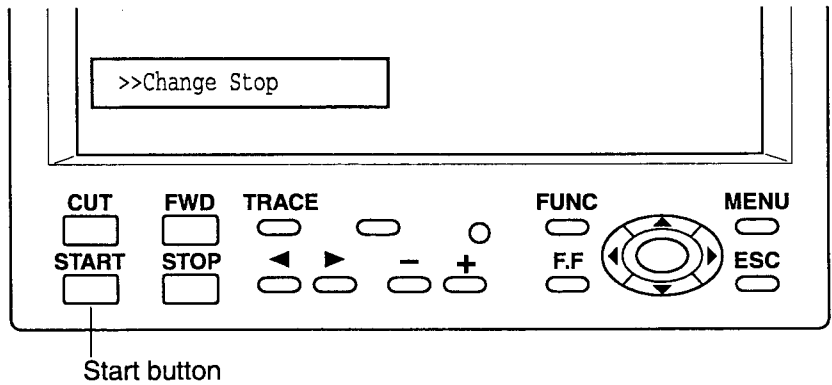

1. When the machine is stopped, press **MENU** and Select "NEEDLE" with

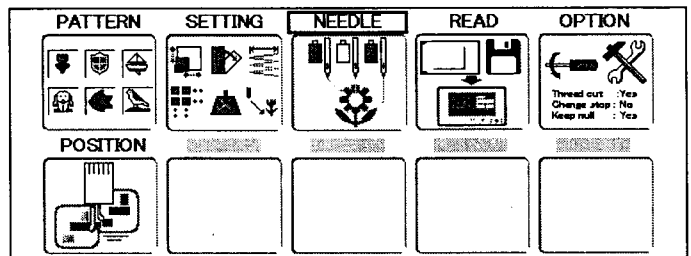

2. Press the **SET**.

The left side of display shows the number, name and details of the current pattern.

- Number of stitches
- Angle
- P** Convert
- Number of Color change number
- Height
- Width
- Size between start point and the top of pattern
- Size between start point and the bottom of pattern
- Size between start point and the extreme right of pattern
- Size between start point and the extreme left of pattern

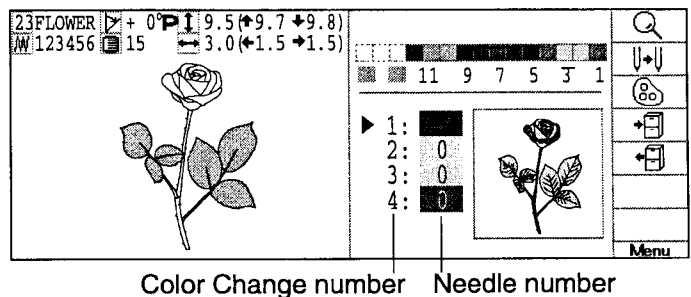

3. Press up/down of to select the Color change number.

The current color number is shown in the pattern data display portion.

4. The color change stop function is set by pressing **SET**.

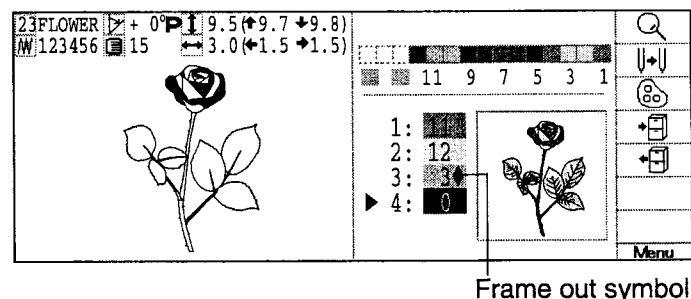

The function is also cancelled by the **SET**.

The setting is fixed.

Color change stop function cannot be used if there is (Frame out) indication at right side of needle no.

Please cancel at Frame out setting. **P** 12-E

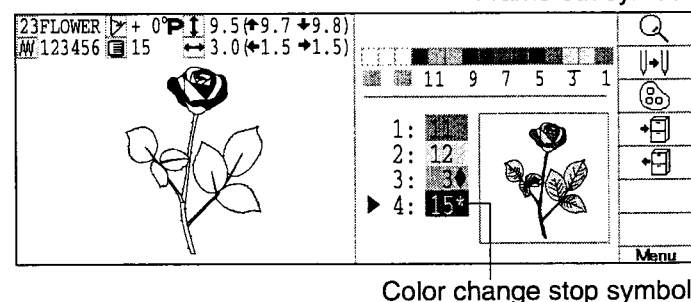

Press **ESC** to return to Menu mode.

Press **ESC** once again to return to Drive mode.

● Installing and removing the frame base

Please attach the frame base to the carriage when you wish to use a tubular embroidering hoop. Please remove it in the reverse order of installation.

1. Move the carriage to the position as shown

by pressing the “Up” or “Down”  on the control box.

Left side of display shows the size of pattern data.

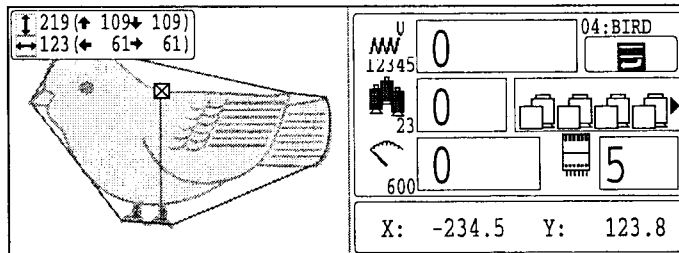

2. Move the fixing base to the approximate center of carriage (left to right) using the

“Left” and “Right” .

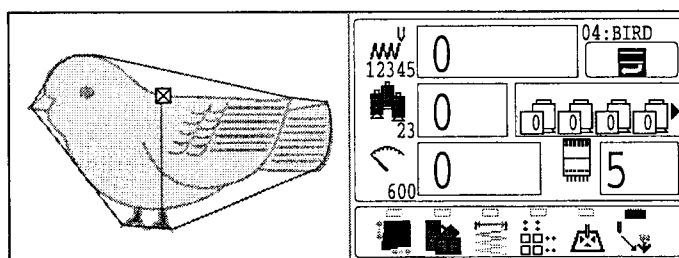

3. Place the frame base on the carriage guide and tighten the knob bolt on the tubular arm holder completely.

Move the frame base right or left when it is hard to go to the knob bolt.

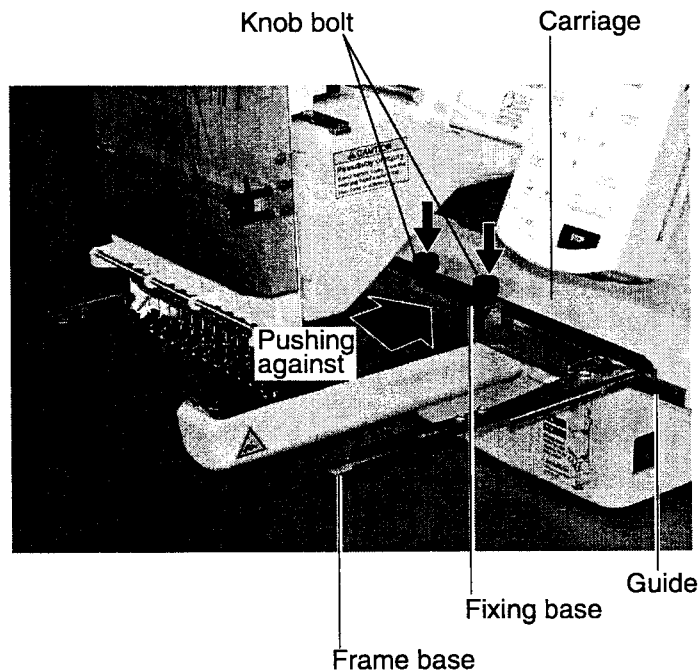

●How to hoop

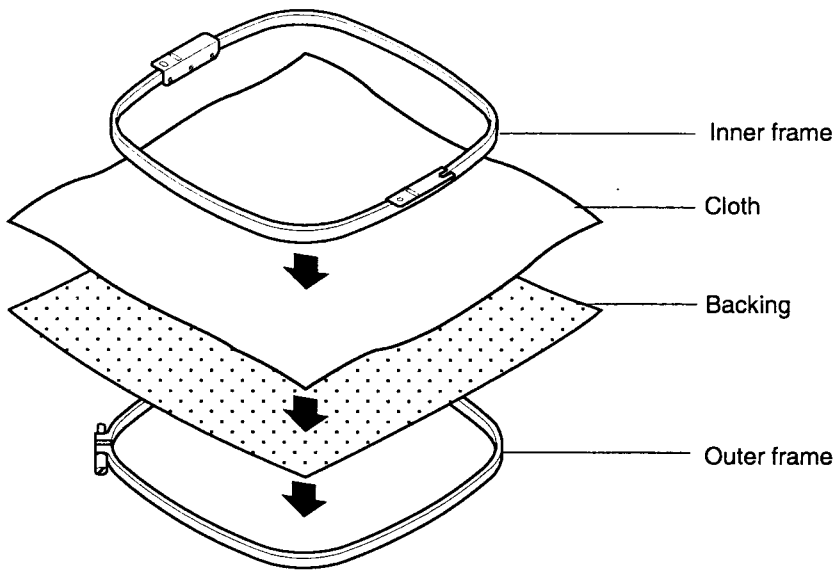

Please smooth the embroidery cloth in all directions, but do not stretch it.

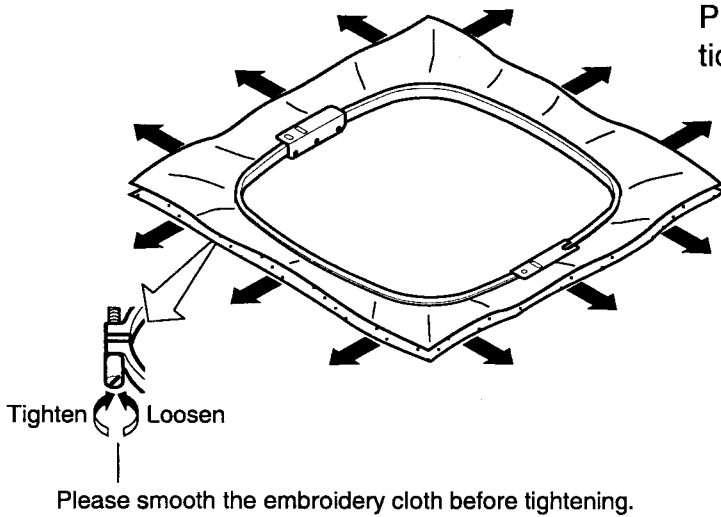

● Putting the hoop on the machine

1. Move the frame base to the approximate center position before inserting the tubular embroidering frame.

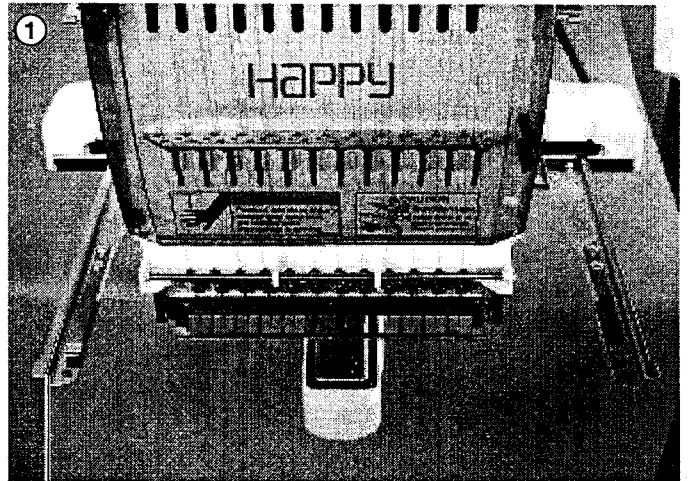

Frame base

2. Insert the embroidery frame.

Make sure that the holder pins are inserted into the positioning holes of the frame base on each side.

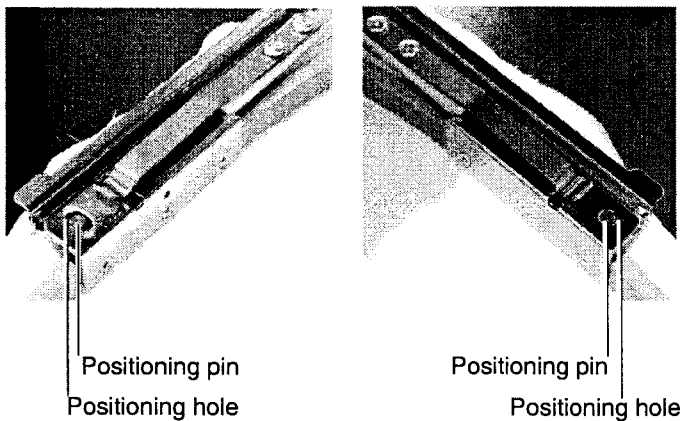
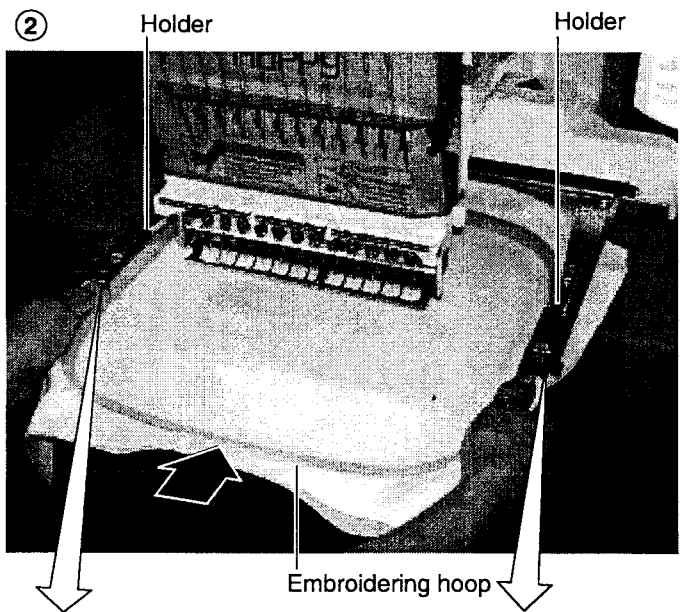

● Starting to embroider

1. Move the frame to the original point with the



● : Original point
(Start point)

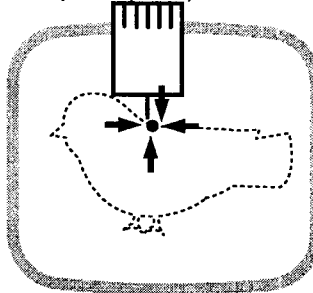

2. Press the **TRACE**.

The embroidering frame moves for the design trace.  14-5

Make sure that the pressure foot and needle do not touch the frame.

If you keep pressing the **START**, the machine will discontinue tracing and move to the original point to start embroidering.

Go on to step 4 if you want to start embroidering without tracing.

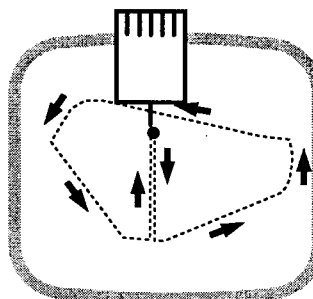

You can confirm outline trace and the position of the design.

3. The display will show ">>Trace end" and the embroidery frame will stop moving.

The embroidering frame has moved to the first stitch point of the pattern.

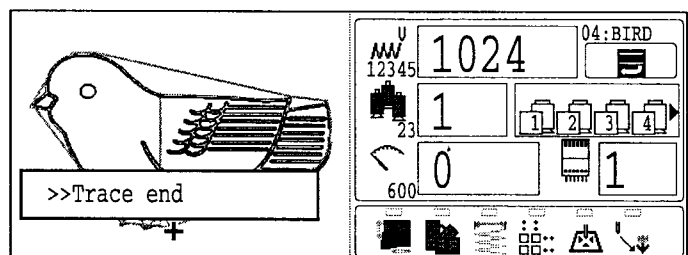

4. Press the **START**.

The embroidery will start.

5. After finishing your design, the display will show ">>End" and the machine will stop.

The embroidery frame returns to the original point automatically if the auto origin function has been activated.

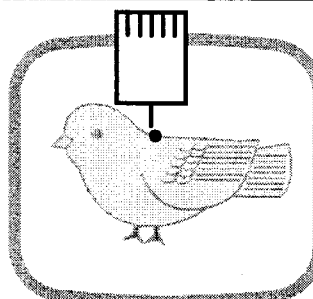
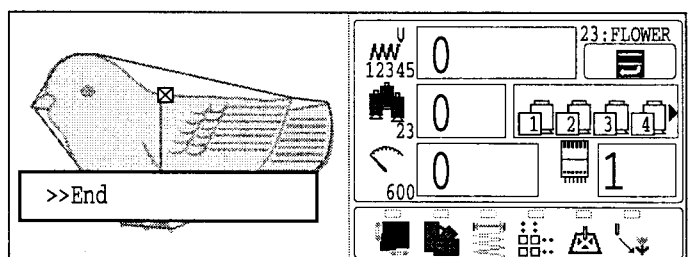

● Cap frame settings

2 types of cap frames, Normal and Wide, are available with this model. When you embroider by using a cap frame, please ensure that a correct setting is selected according to each.



CAUTION: To avoid problems.

The machine and/or cap frame may be damaged if the incorrect frame settings are used.

1. When the machine is stopped, press **MENU** and Select "OPTION" with .

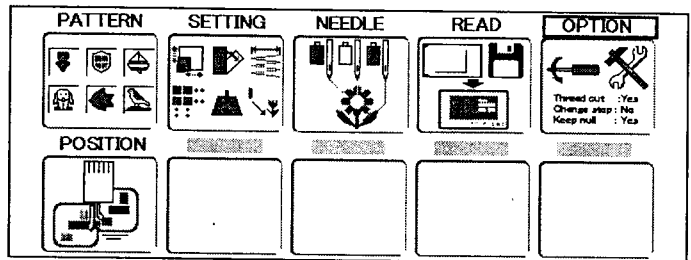

2. Press the **SET** button.

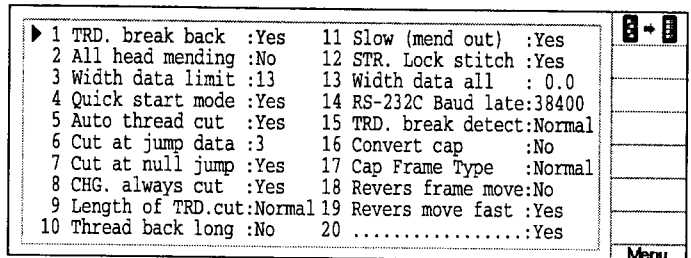

3. Select "Cap Frame Type" with .

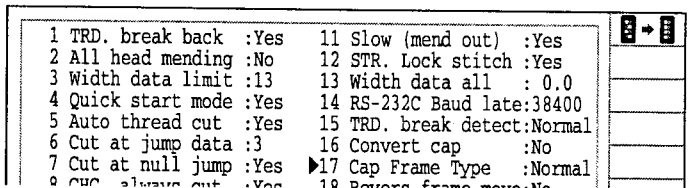

4. Press the **SET** and select "Normal" or "Wide" with .

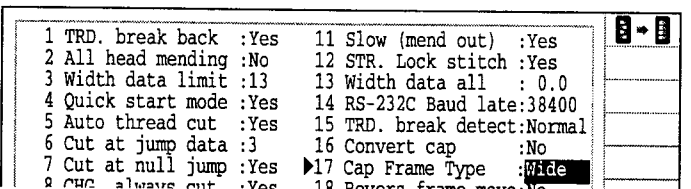

5. Press the **SET**.
The setting is fixed.

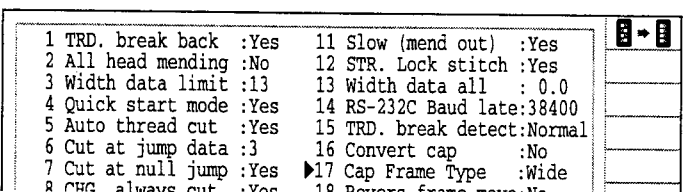

Press **ESC** to return to Menu mode.
Press **ESC** once again to return to Drive mode.

● Changing the needle plate

You need to change the needle plate when you embroider a cap.

1. Remove the set screw (2 pieces) by offset driver and remove the needle plate.

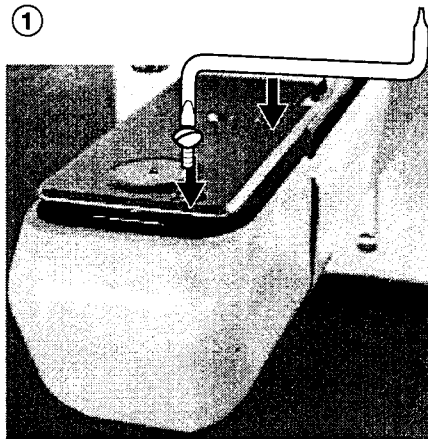

2. Put the needle plate for cap on the bed and tighten with the set screw.

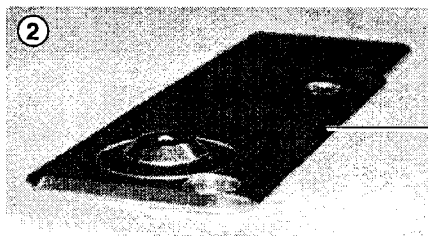

3. Loosen the set screw (upper side) of pressure foot and unscrew the set screw (lower side).

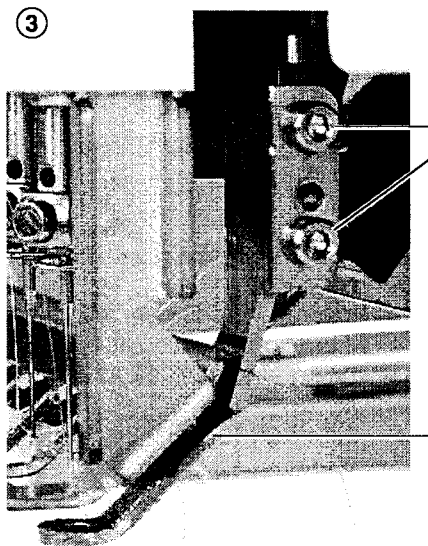

4. Press up the pressure foot and tighten set screw (upper side) and tighten set screw (lower side) as it shown in the diagram.

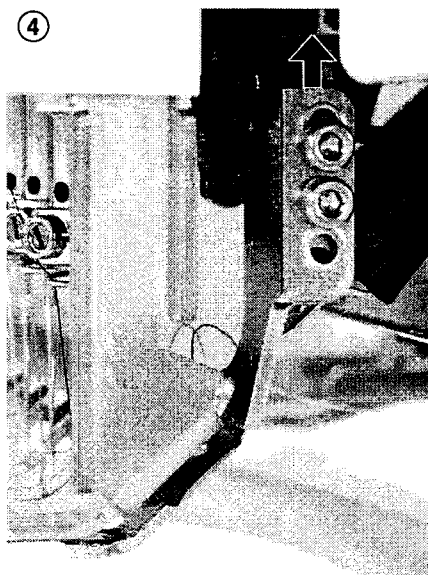

● Installing and removing the cap drive frame

You need to install the cap drive frame into the carriage when you embroider a cap.
Please remove by reverse order of these step.

1. When the machine is stopped, press **(MENU)**

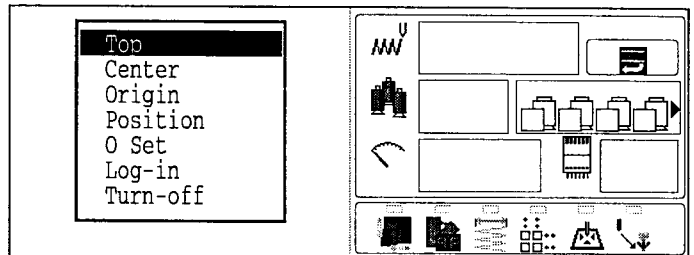

2. Select "Center" with **(Left/Right Arrow)** and press **(SET)**.

The embroidery frame will move to the center automatically.

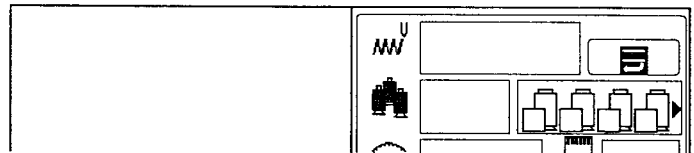

CAUTION: To prevent accidents.
The frame moves quickly.
Keep hands away from the frame.

3. Turn on the power switch.



4. Hold the arc guide by hand and the rail bracket has to be faced downward, then install into the bed as showing picture.

When you hold the cap drive frame assembly, be sure to hold it by the guide.

If you hold the rail bracket, your fingers will be pout between the rail bracket and the rail bracket rotary cylinder and rail bracket can get out of place.

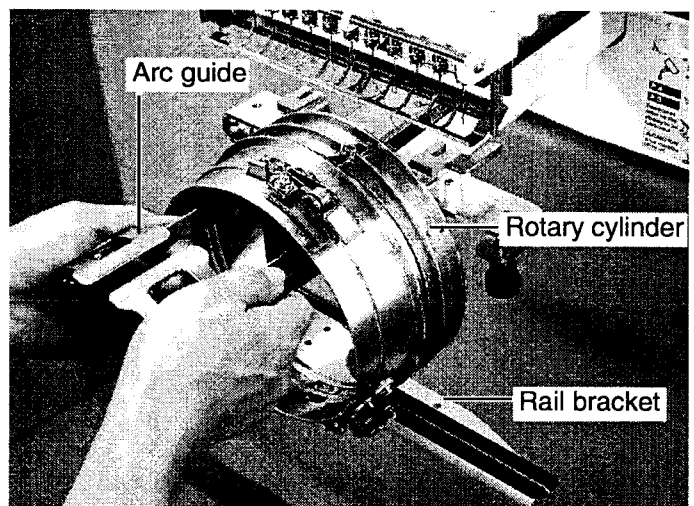

5. Move the cap drive frame backwards away from you and rotate the rotary cylinder until the rail bracket is upward as shown at right.

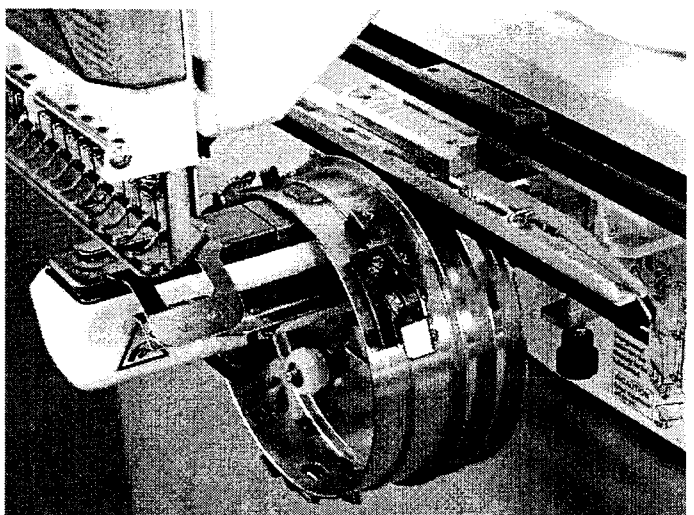

CAP FRAME (OPTION)

6. Move the cap drive frame in the direction of the arrow, adjust right-and-left mount base to carriage arm and fix them by knob bolts.

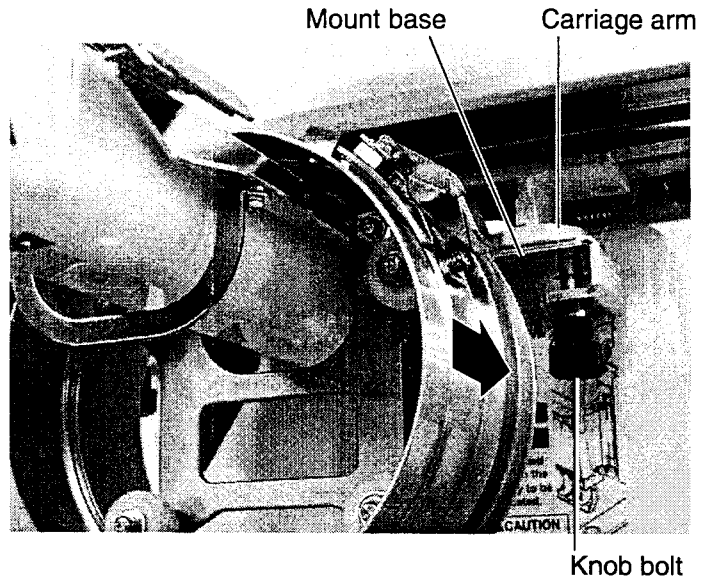

7. Fix the rail bracket to fixing base by knob bolts.

You can move the fixing base right or left when it is hard to get to the set screw.

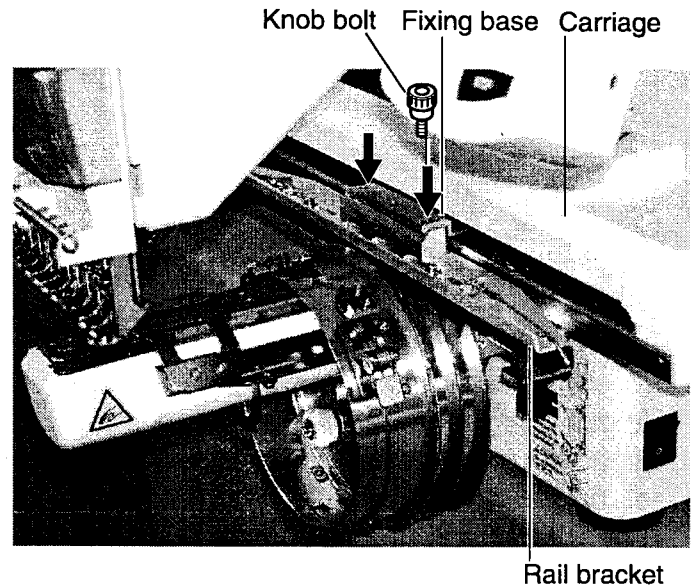



8. Turn on the power switch.



9. Press the **SET**.

The embroidery frame will move to the center automatically.

Icon of  (Normal cap) or  (Wide cap) will be shown in the upper right corner of the screen. Then Cap Mode will be set.

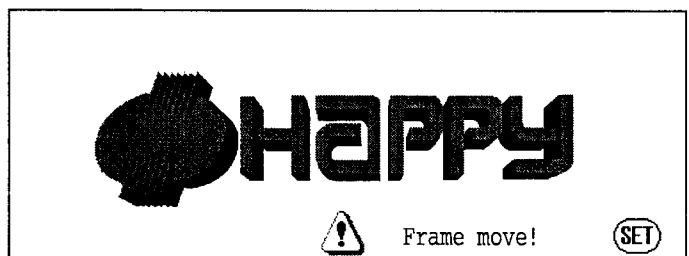

CAUTION: To prevent accidents.
The frame moves quickly.
Keep hands away from the frame.

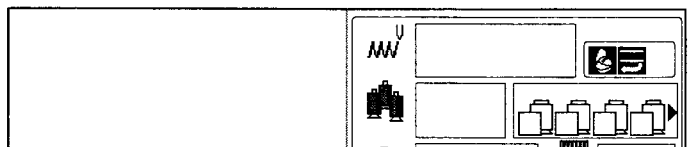

● Normal cap frame

Adjustment

When you hoop a cap on the cap frame, please adjust in the following manner:

1. Adjust position of clamp support to the height of the cap. (Fig. 1)
Adjust the height by removing the inner screws at left and right.

If you adjust position of clamp support and shorten distance H, embroidery area will be reduced in Y direction (depth).

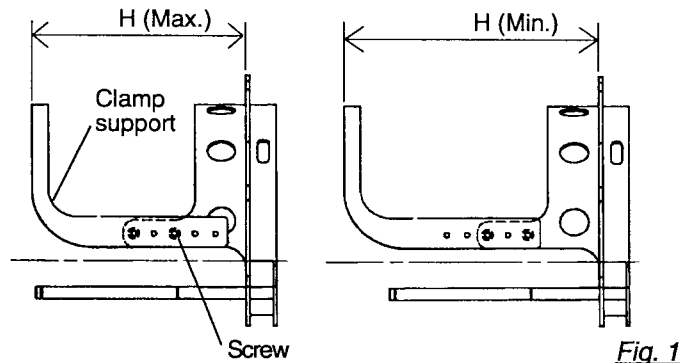

2. Adjust the clamp to fit the clamp support. (Fig. 2)
Loosen wing nuts at left and right to adjust.

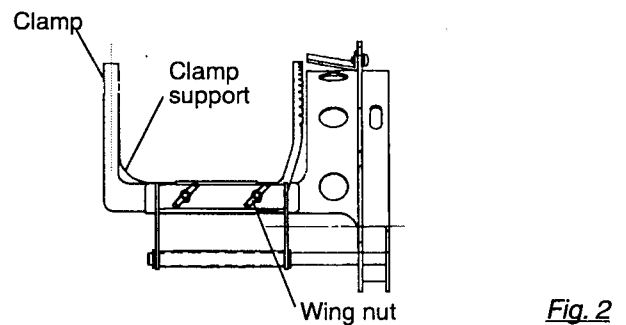

3. Adjust up and down position of the hook according to the thickness of the cap to adjust clamp tension. At this moment, the hook should open and close without feeling too tight. (For adjustment, proceed to procedure 5 below).
Use the wing nuts for adjustment. (Fig. 3)

If the hook is extremely tight, it will damage the cap frame permanently.

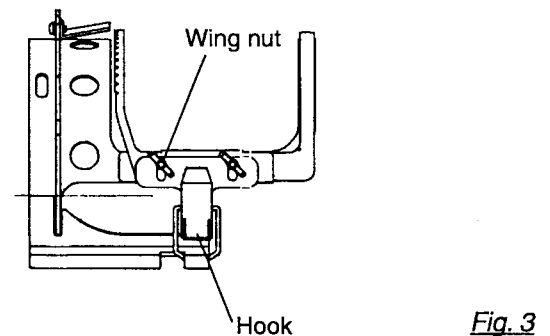

4. Put the cap frame without a cap to cap drive on the machine. (Please refer to operation 8 "Hooping caps" on next page for mounting).
At this time, adjust so that guide on cap drive frame doesn't strike clamp support and gap is reduced as small as possible. Remove screws at left and right to adjust. (Fig. 4)

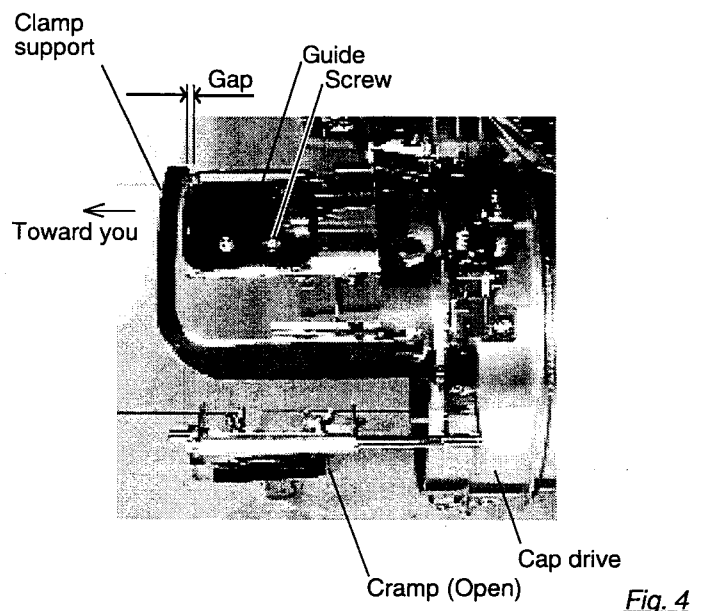

CAP FRAME (OPTION)

7-6

Hooping caps

1. Place cap stretcher securely on a sturdy work bench.
2. As shown in Fig. 5, hold cap frame with both hands and place on cap stretcher. By pushing locking levers at 2 places with fingers, place cap frame so that center guide of cap stretcher fits in concave area of cap frame.

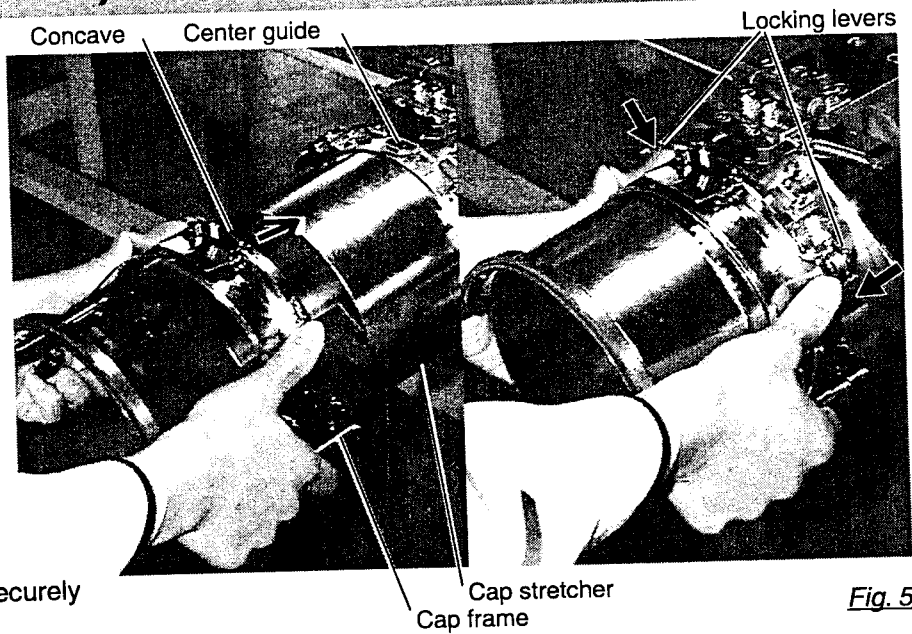

Fig. 5

Confirm that the cap frame is securely placed on cap stretcher.

3. As shown in Fig. 6, open clamp and keep open to the right.
4. Turn the sweatband of the cap inside out a slide onto the cap frame as shown. Place it so that the edge of the sweatband contacts the flange of the cap frame.

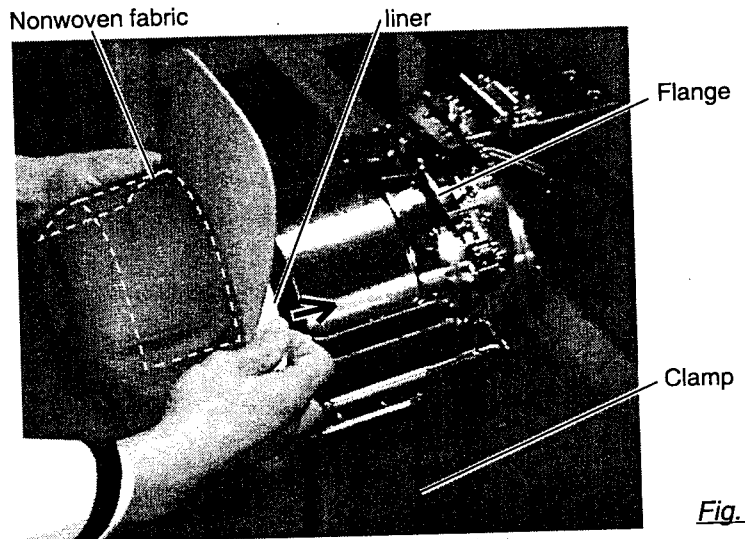

Fig. 6

Please place one or two sheets of non-woven fabric (backing) of standard thickness under unstructured caps.

5. As shown in Fig. 7, pull back part of cap and hook it on the hook and smooth out creases on cap. At this time, align the center of the cap to the center mark on the cap frame so that notched portion of the clamp fits into the seam of the visor.

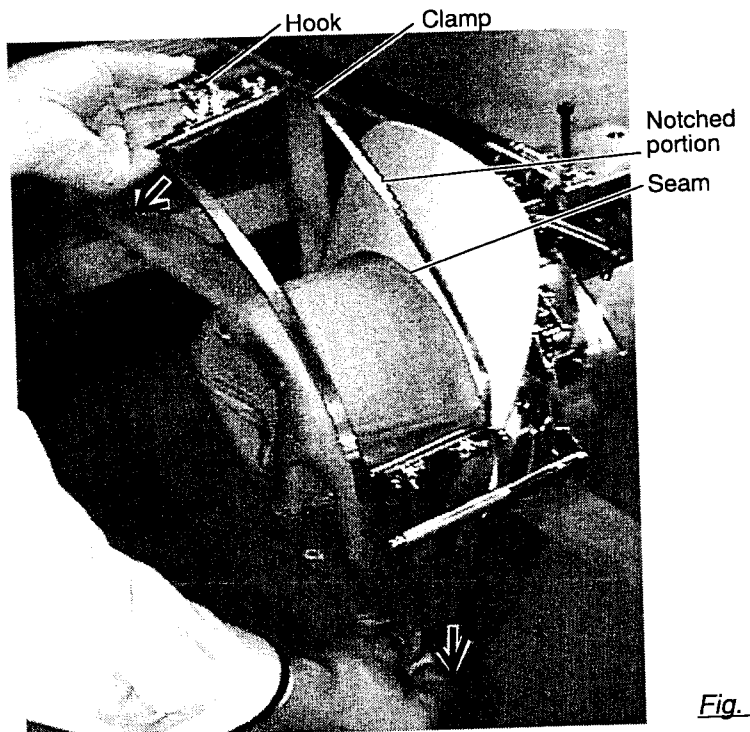

Fig. 7

6. Latch the hook, taking care not to cause wrinkles in the cap.

If you can't get rid of wrinkles on the cap, adjust the cap frame again according to "Adjustment" on the previous.

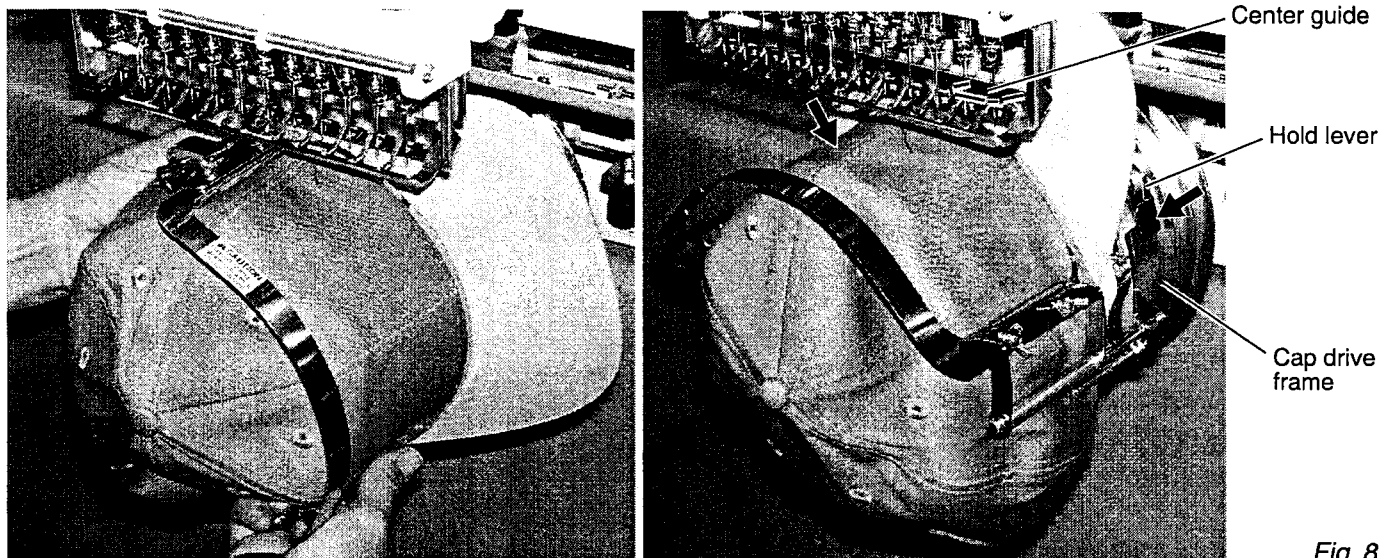

Fig. 8

7. Remove the cap frame from the cap stretcher.

8. As shown in Fig. 8, place the cap frame on cap the drive frame.
You will have to rotate the brim of the hat to the side in order to get past the needle case.
Then, push the holder lever in the 2 places shown, and place the cap frame on so that the center guide of the drive frame assembly fits into the cap frame notch.

Confirm that the frame is firmly seated on the cap drive frame assembly without any gaps.
If there is a gap between the cap frame or the cap drive holding lever doesn't go into the hole of the cap frame, loosen the set screw on the hold lever for adjustment.

● Wide cap frame

Adjustment

When you fix cap to cap hold frame, please adjust in the following manner.

Make sure to do the adjustment of the cap hold frame. If it is not adjusted properly, it may cause the deformity, damage of the cap, damage of the cap hold frame and break of the cap grip.

After adjusting the cap hold frame, make sure the cap to be set properly.

1. Adjust the length of the cap grip to suit the thickness of the fabric. At this moment, hook should open and close without feeling heavy. (For the adjustment follow the next page "Hooping caps" item 1 to 5.) The adjustment to be done by three adjusting screws. (Fig. 1)

If the cap grip is loose, even after hooked the cap is not fixed tightly and the cap is moving. (Fig. 2)

If the cap grip is too tight, you feel heavy when it is hooked and the grip bites into the cap too much. (Fig. 3)

If you feel hook extremely heavy in opening and closing, there is a case that cap hold frame will lose its shape or damage.

2. Adjust the guide position to suit the height of the cap. Remove screws at left and right to adjust. (Fig. 4)

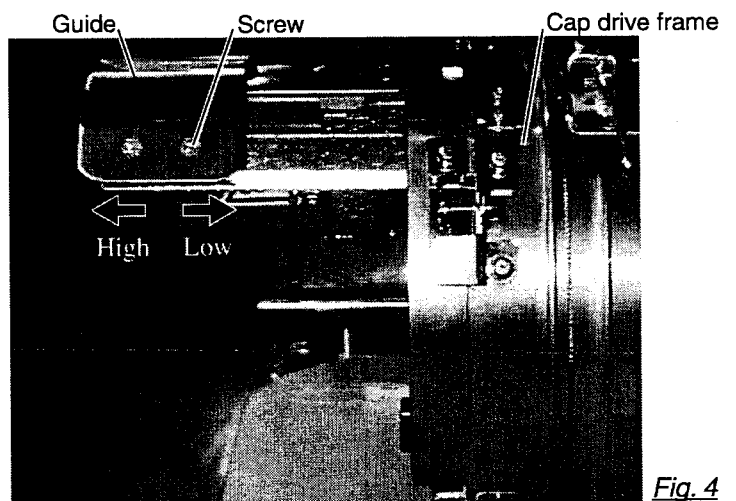
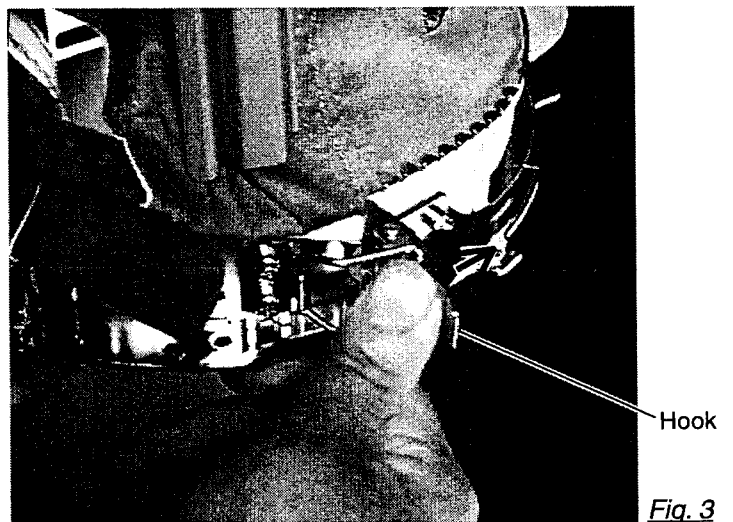
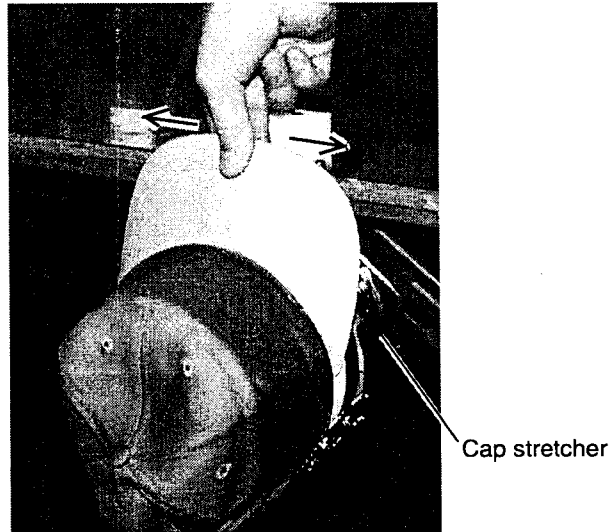
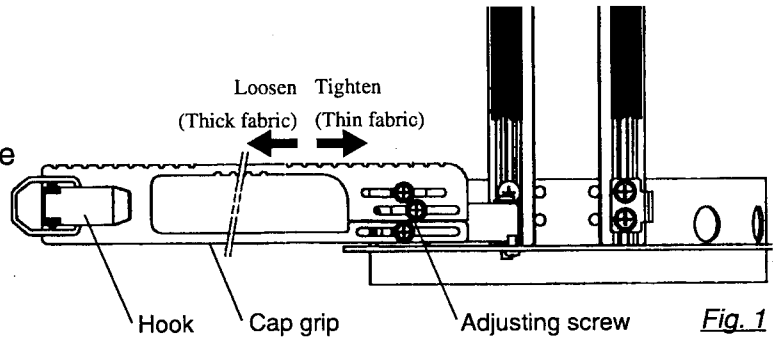

CAP FRAME (OPTION)

7-9

Hooping caps

1. Place cap stretcher securely on sturdy work bench.
2. As shown in Fig. 1, hold cap hold frame with both hands and place on cap stretcher. By pushing hold lever at 3 places in arrow marks with fingers, place cap hold frame so that center guide of cap stretcher gets in concave of upper cap hold frame.

Confirm that cap holder frame is securely placed on cap stretcher without gap.

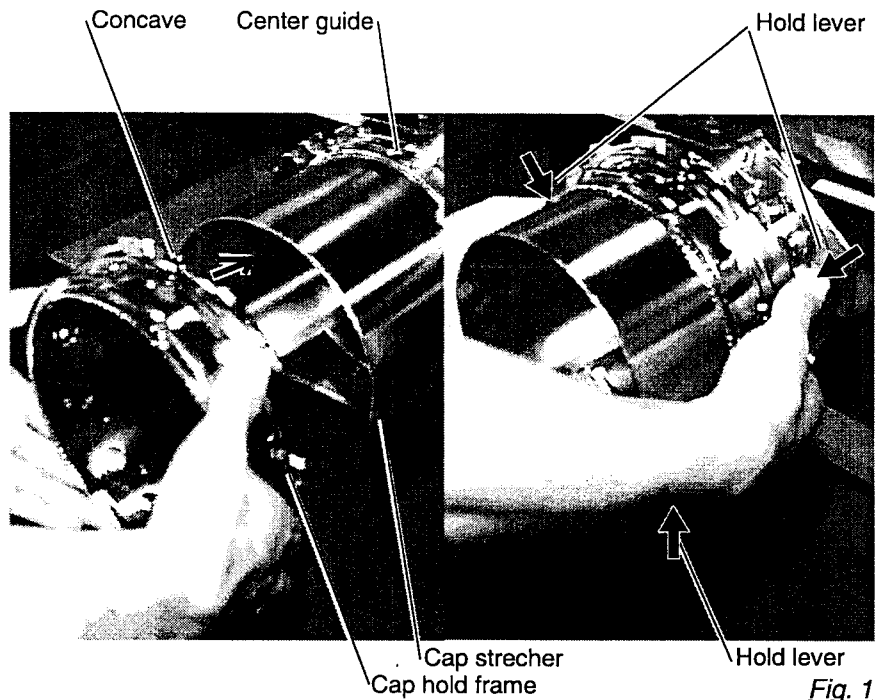

Fig. 1

3. As shown in Fig. 2, remove cap grip and keep open to the left.
4. Extend fore half of liner inside cap toward outward and place on cap stretcher. At this moment, place it so that tip of liner contacts flange of cap hold frame.

Please place one or two sheets of nonwoven fabric (backing) of standard thickness under unstructured caps. The length of nonwoven fabric should be some as one of round of cap.

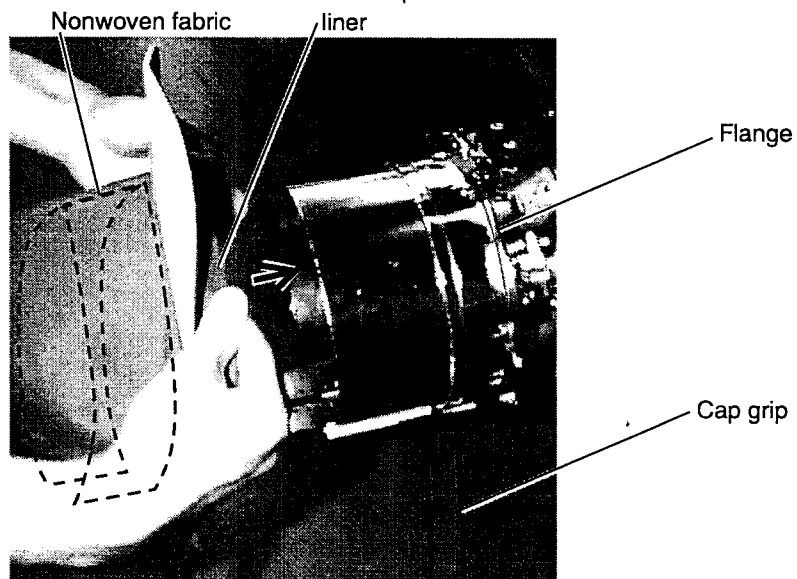

Fig. 2

5. As shown in Fig. 3, place hook so as to have visor of cap get in gap between cap grips. At this moment, set center of cap to center mark on cap hold frame so that notched portion of clamp gets into seam of visor. Close hook.

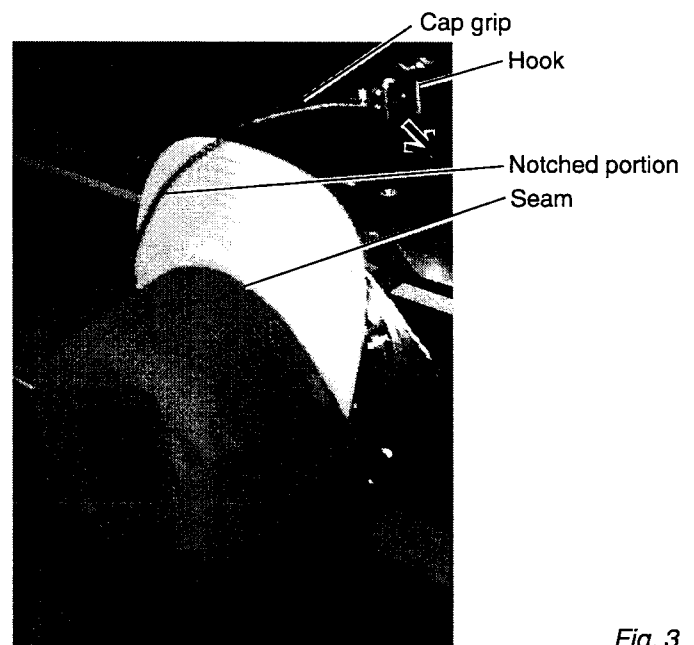

Fig. 3

CAP FRAME (OPTION)

7-A

6. As shown in Fig. 4, tip the cap stretcher forward. Clip the back of the cap in two places by stretching the crease out as shown by the arrows.

Make the clip lever face the inside.

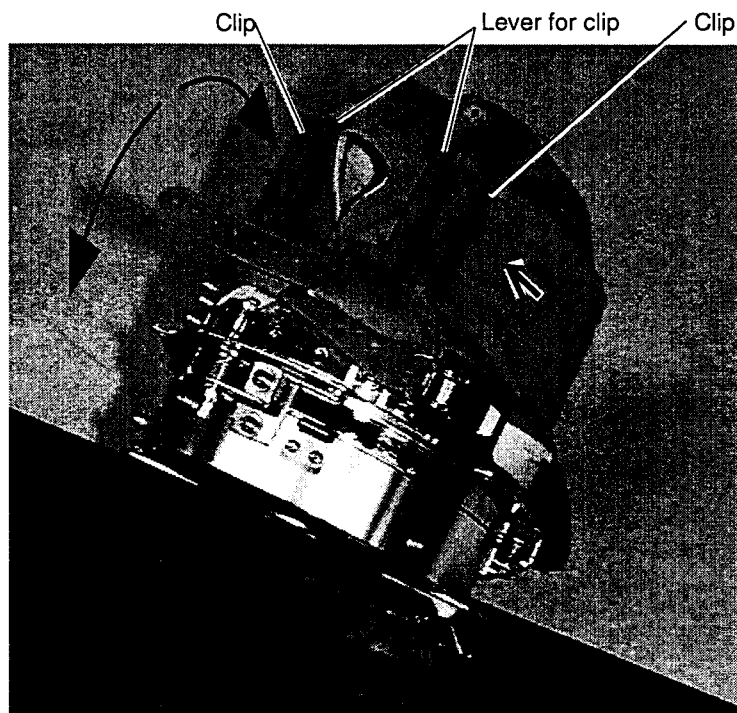

Fig. 1

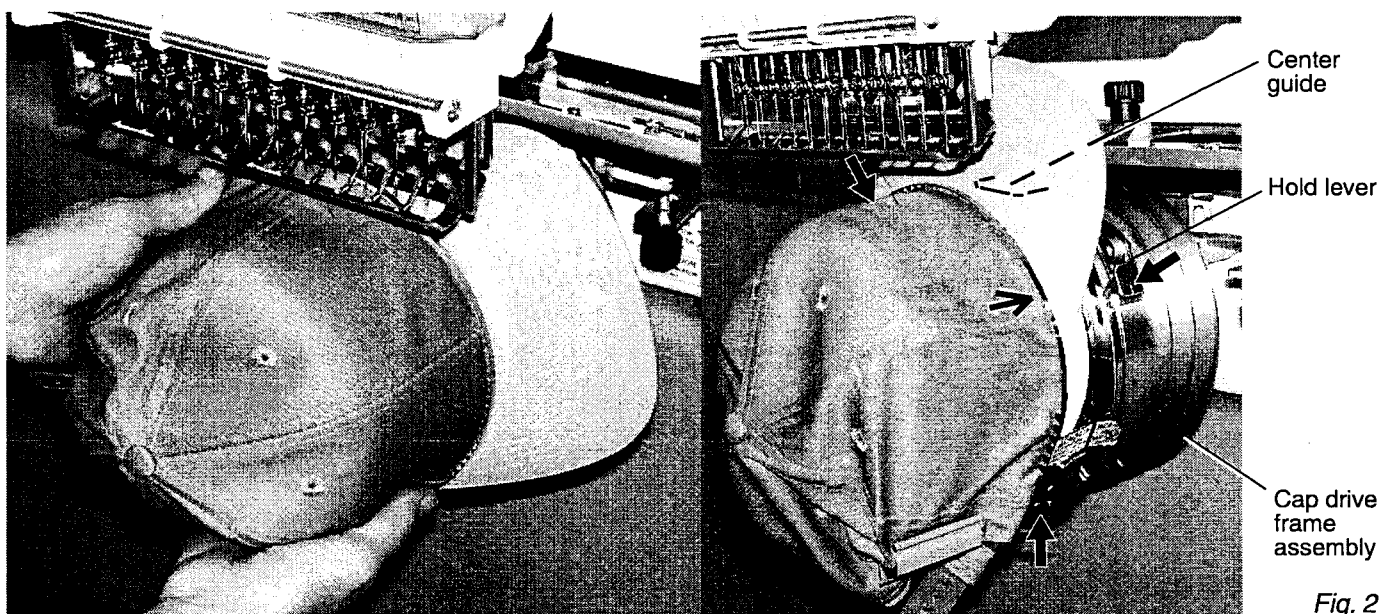

Fig. 2

7. Remove the cap holder frame from the cap stretcher.
8. As shown in Fig. 5, place the cap holder frame the cap drive frame assembly. Push the hold lever in at 3 places as shown by the marks and place the cap holder frame so that center guide of the drive frame assembly gets in the upper cap holder frame.

Confirm that the cap holder frame is firmly attached to the cap drive frame assembly without any gaps. If there is a gap between cap holder frame and the cap drive frame, or hold lever doesn't go into hole on the cap holder frame well, loosen the set screw on the lever to adjust.

● Starting to embroider

1. When the machine is stopped, press **(FUNC)**.

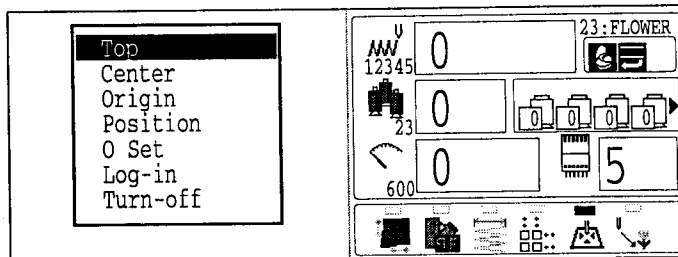

2. Select "Center" with  and press **(SET)**.

The embroidery frame will move to the center of the embroidery area automatically.

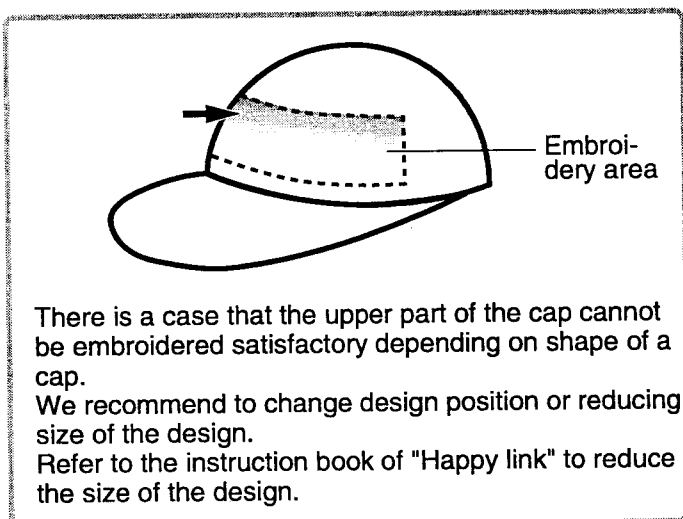
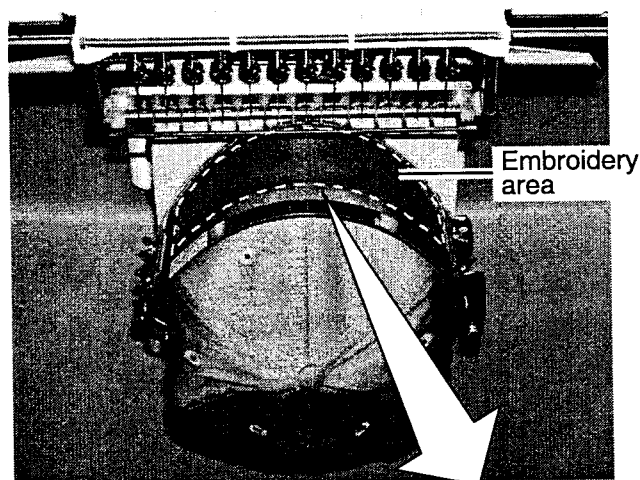

Embroidery area (Max. *1)

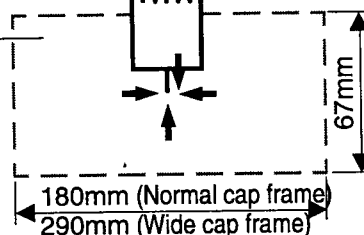

* The actual embroidery area will be restricted by the design and shape of a cap.

3. Move the frame to the original point of pattern data by .

●:Original point (Start point)

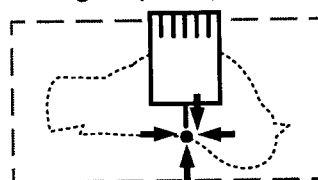

4. Press the **(TRACE)**.

The frame will start moving for the design trace.

 14-5

Make sure that the pressure foot and needle does not touch the frame.

If you hold the **(START)**, the machine will discontinue tracing and move to the original point to start embroidering.

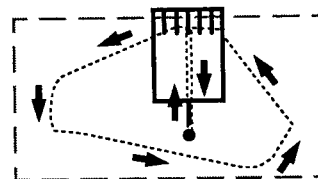

You can confirm the outline and position of design.

Go on to step 6 if you want to start embroidering without tracing first.

CAP FRAME option

7-C

5. The display will show ">>Trace end" and the embroidery frame will stop moving.

The embroidering frame will return to the first stitch point of the pattern.

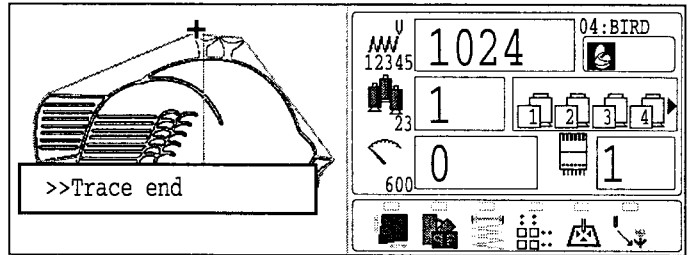

6. Press the **START**.
Embroidery will start.

7. After finishing your design, the display will show ">>End" and the machine will stop.

The embroidery frame will return to the original point automatically if the auto origin function has been activated. 12-7

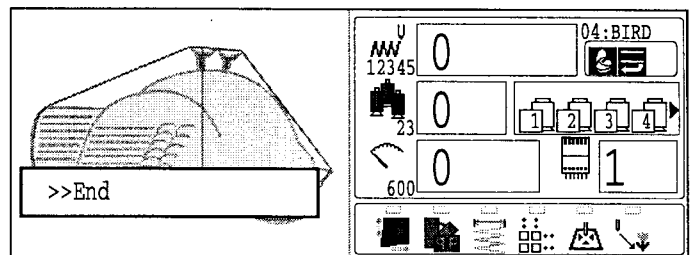

●:Original point (Start point)

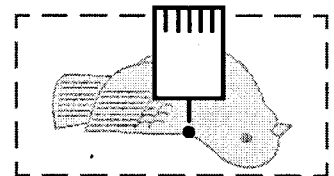

ADJUSTING THE THREAD TENSIONS

8-1

1. With the thread going through the hole of the pressure foot, pull it out slowly toward the front.

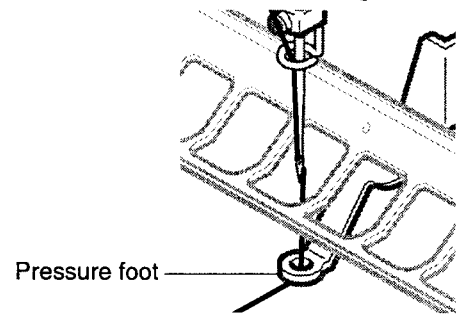
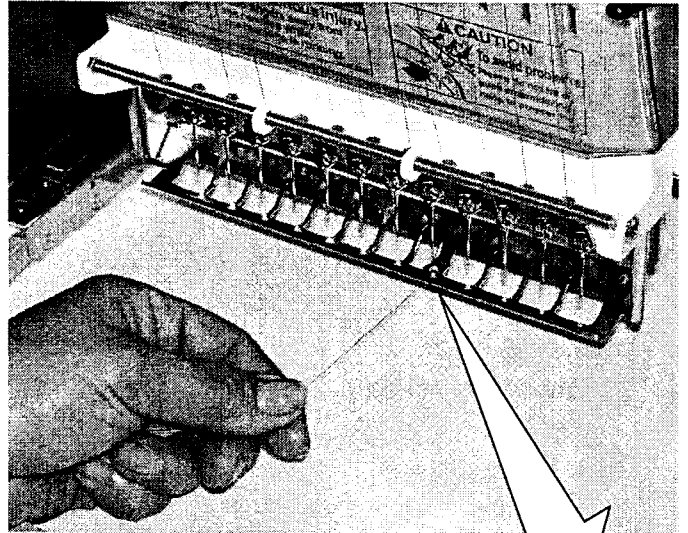

2. Adjust the Minor thread tension by the first tension knob and then the second Thread tension knob.

According to the type of upper thread and cloth.

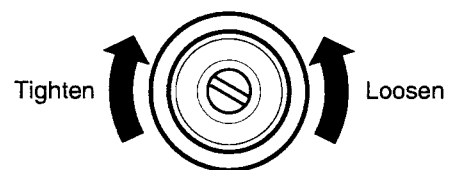
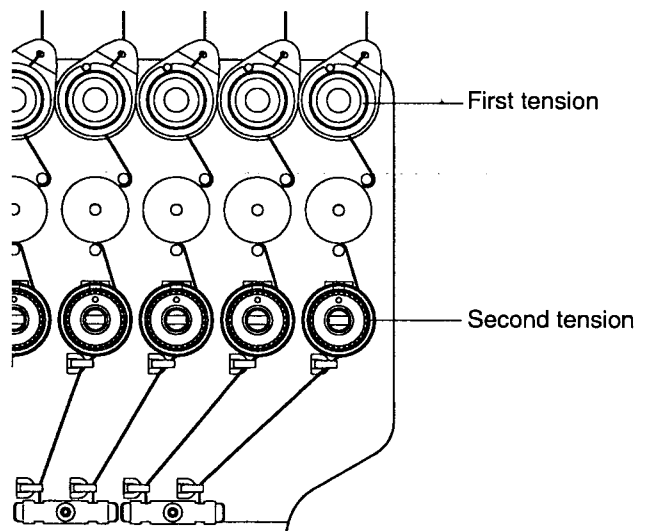

● What to do if the thread breaks while sewing

If the thread breaks or runs out while sewing, the machine senses the break, stops, and moves back several stitches from the break point.

(This prevents open sections in the design when sewing is resumed. See the thread break section. P5-1)

If the upper thread breaks

Thread the upper thread again.

(Refer to P4-6)

In case bobbin thread breaks

Thread lower thread again.

(See bobbin winding P4-5)

● Stopping and resuming sewing

If you need to turn off the machine in the middle of a design, you may resume from the stop point after turning on the machine back on.

- If you leave the machine off for too long, the fabric may distort which will create gaps in the embroidery design.

Example: An unsatisfactory gap between lines because the machine stopped at a half point in embroidery and the material shrunk.

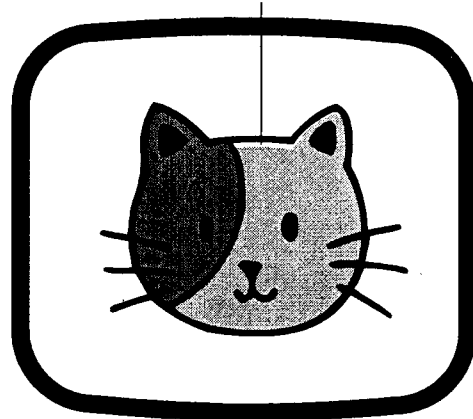

To suspend sewing

1. Stop the sewing by pressing the **STOP** button.
2. Press the **CUT** button.
The needle will go down and trim the thread.
3. Turn off the power switch.

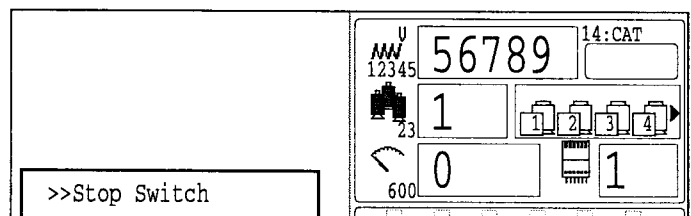

To resume sewing again from the last sewn position:

4. Turn on the power switch.
5. Press the **SET** button.
After the carriage and frame move slightly, the embroidery frame will return to the previous position automatically.
6. Back up several stitches from the stop point by pressing the **STOP** 3-4 times.
7. Start sewing again by pressing the **START**.

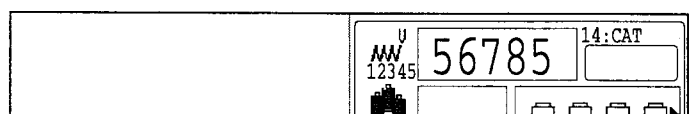
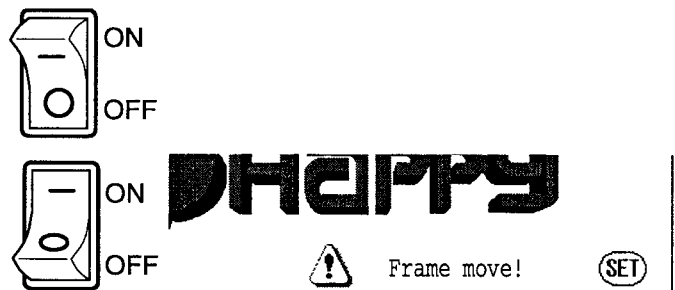

CAUTION: To prevent accidents.
When performing a thread trim, be careful of the needle which will pierce the fabric.

CAUTION: To prevent accidents.
The frame moves quickly.
Keep your hands and body clear of the machine.

● Loss of power while embroidering

If you have a power failure while embroidering, follow these instructions and you can restore the position of the frame and the pattern data to its state before the failure.

1. Turn on the power switch.



2. Press the **SET**.

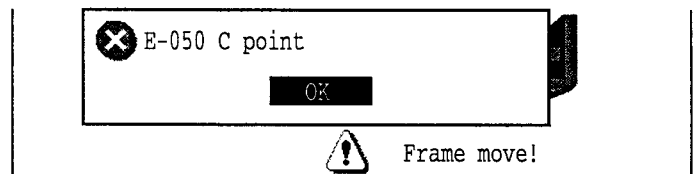

3. Press the **SET**.



4. Select "Auto" with  and press **SET**.
The main shaft will make one rotation and stop at the "C" point (proper stop position).

5. Press the **CUT**.
The needle will go down and trim the thread.

6. Press the **SET**.
After the carriage and frame move slightly, the embroidery frame will return to the previous position automatically.

7. Back up several stitches from the stopped point by pressing the **STOP**.

8. Start sewing again by pressing the **START**.

 **CAUTION: To prevent accidents.**
When performing a thread trim, be careful of the needle which will pierce the fabric.

 **CAUTION: To prevent accidents.**
The frame moves quickly.
Keep your hands and body clear of the machine.

● Moving the hoop while embroidering and then returning to the correct location (Position)

If you wish to move the embroidery frame in the middle of the design, follow these steps:

1. Stop the sewing by pressing the **STOP**.

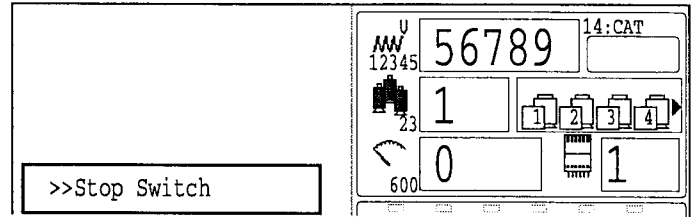

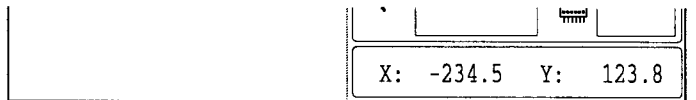

2. Move frame with .

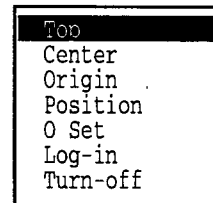

3. Press the **FUNC**.

CAUTION: To prevent accidents.
The frame moves quickly.
Keep hands away from the frame.



4. Select "Position" with  and press **SET**.

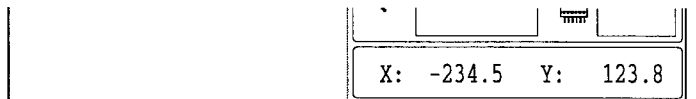

The frame will automatically return to the previous position.

● Moving back to the starting point (Origin)

The frame returns to the origin point (beginning position of design).

The frame returns to the origin point (beginning position of design).

1. Press the **FUNC** when the machine is stopped.

CAUTION: To prevent accidents.
The frame moves quickly.
Keep hands away from the frame.

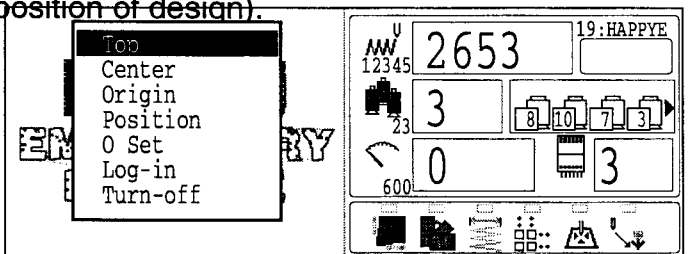

2. Select "Origin" with  and press **SET**.

The frame will move to the origin point and the pattern data will return to the start point.

 (Top) will be shown on the display.

Press **ORG** again to go return to the previous point **ORG**.

 (Top) will be cleared on the display.

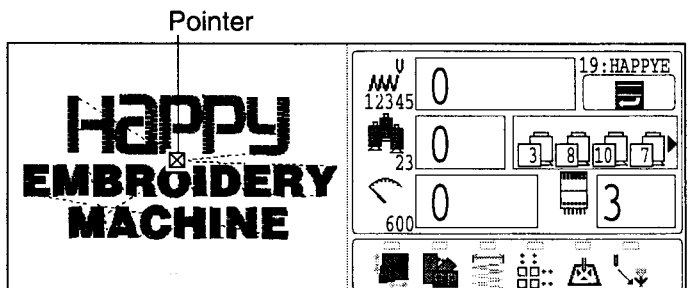

● Going back to the beginning of the design (Top)

Stopping sewing in the middle of a design, changing the design's location in the hoop, and then restarting from the beginning.

If you use "Top", you will return to the start point the frame position left where it is.

1. Press the **(FUNC)** while the machine is stopped.

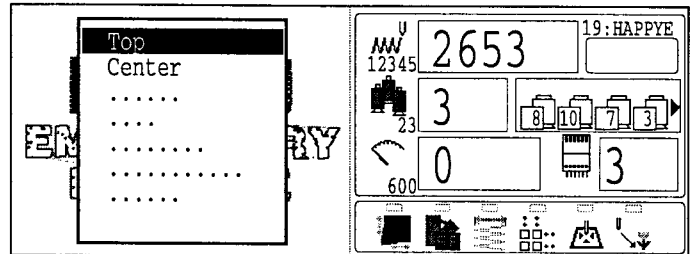

2. Select "Top" with  and press **(SET)**.
The pattern data will return to the start point.

 (Top) will be shown on the display.

If you want to go back to the previous point before "Top", repeat steps 1 and 2 again.

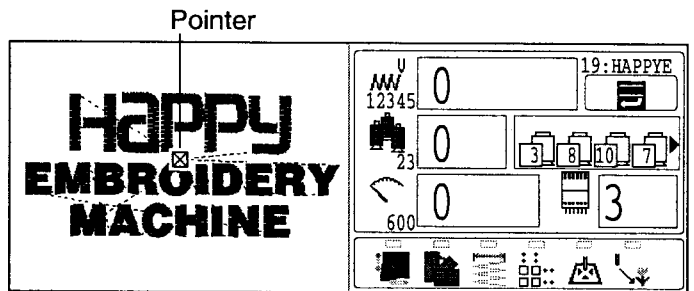



● Placing the design in the center of the selected embroidery frame (Center)

Move embroidery frame position to the center automatically.

1. Press the **(FUNC)** while the machine is stopped.

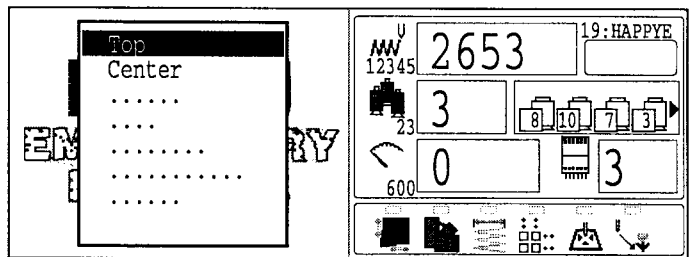
 **CAUTION: To prevent accidents.**
The frame moves quickly.
Keep hands away from the frame.



2. Select "Center" with  and press **(SET)**.
The embroidery frame will move to the center automatically.

If you want to get back to the previous status from "Center". Do procedure of "Position".

 9-3

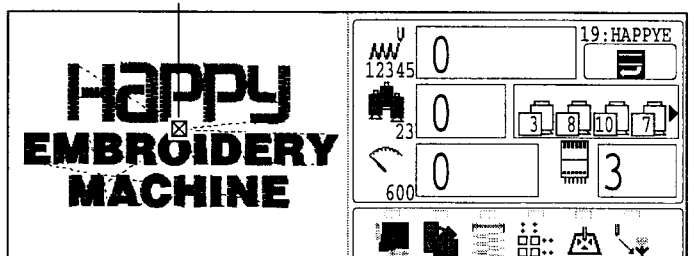

● Rotating and mirroring designs (Convert)

Convert selected pattern data.

Setting example

● : Start point of pattern



Normal Mirror reverse + 90°

With the start point of pattern as a pivot, the machine changes the angle in 90 degree increments.

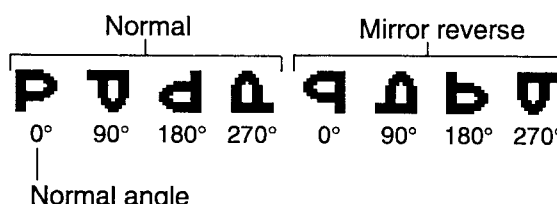

Normal Mirror reverse

0° 90° 180° 270° 0° 90° 180° 270°

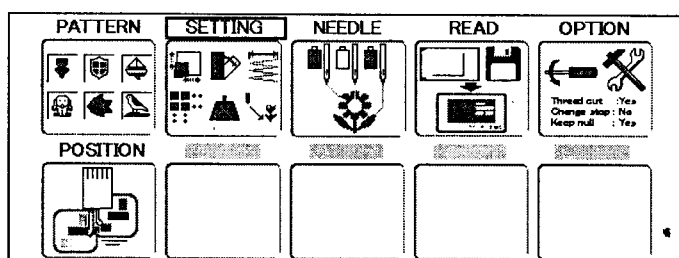

Normal angle

1. When the machine is stopped, press **(MENU)** and Select "SETTING" with .

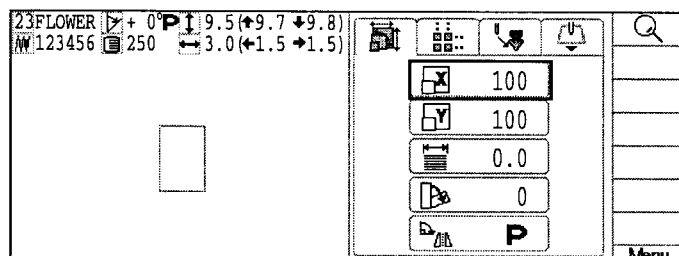

2. Press the **(SET)** button.
The left side shows the number, name and details of the current pattern.



3. Press up/down of  to select  and press **(SET)**.

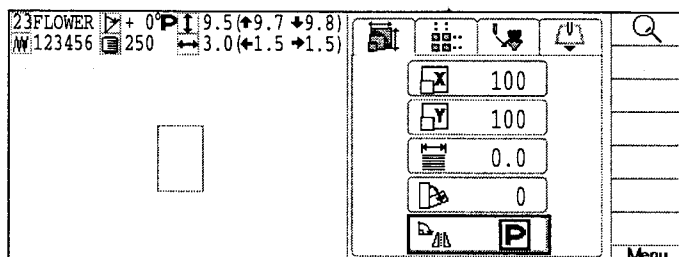

4. Press up/down of  to select conversion of position required.

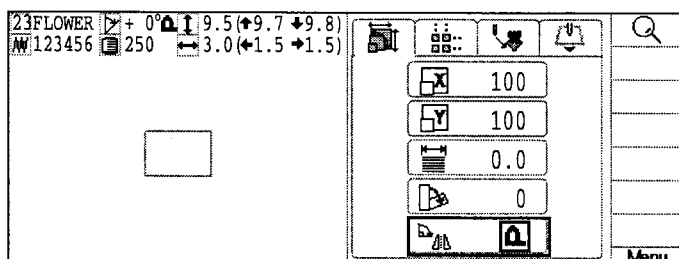

5. Press the **(SET)**.
The setting is fixed.

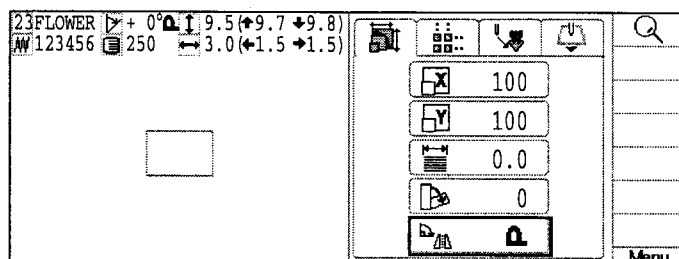

Press **(ESC)** to return to Menu mode.
Press **(ESC)** once again to return to Drive mode.

● Starting in the middle of a design (POSITION)

This function allows you to go directly to a stitch number or a color change and positions the hoop correctly.

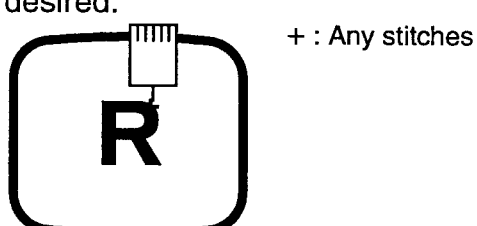
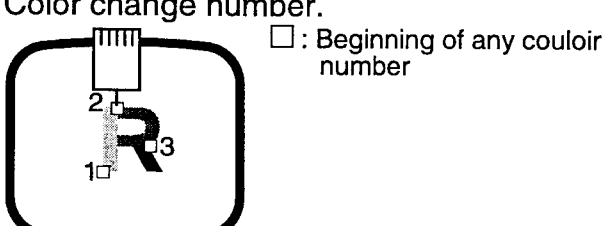
<p>Stitch (Number of stitches) This moves the frame to any stitch number desired.</p>  <p>+ : Any stitches</p>	<p>Change (Color position) This moves the frame to the beginning of any Color change number.</p>  <p>□ : Beginning of any colour number</p>
---	---

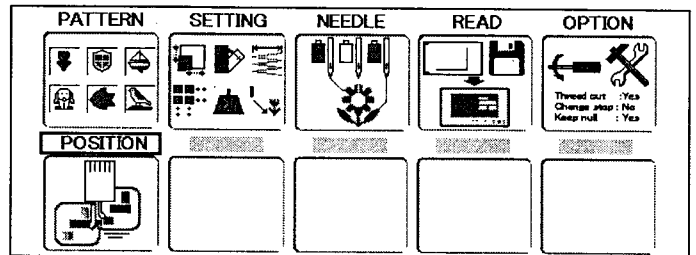

Stitch

1. When the machine is stopped, press **MENU** and Select "POSITION" with .



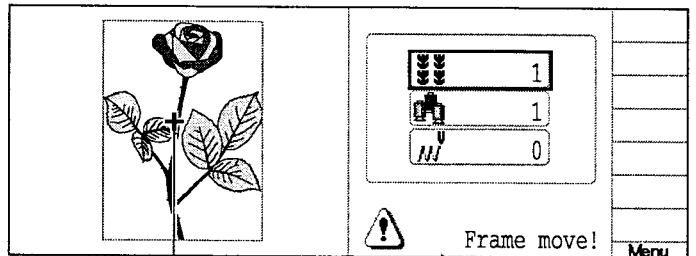

2. Press the **SET** button.

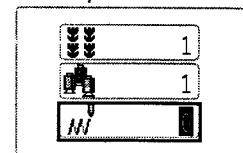

3. Press up/down of  to select  and press **SET**.

Pointer shows you the current position of the frame.



4. Press up/down of  to select the number and press right /left of  to select the digit.

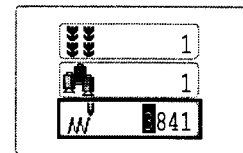

5. Press the **SET** button.
The frame will move to the selected stitch number position.

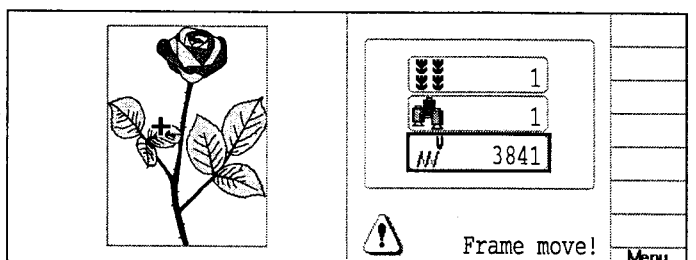

CAUTION: To prevent accidents.
The frame moves quickly.
Keep hands away from the frame.

Press **ESC** to return to Menu mode.
Press **ESC** once again to return to Drive mode.

Change

1. When the machine is stopped, press **(MENU)** and Select "POSITION" with .

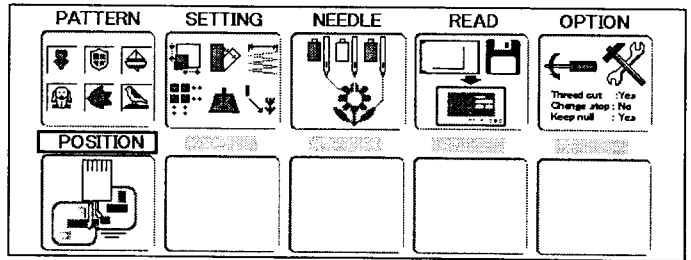

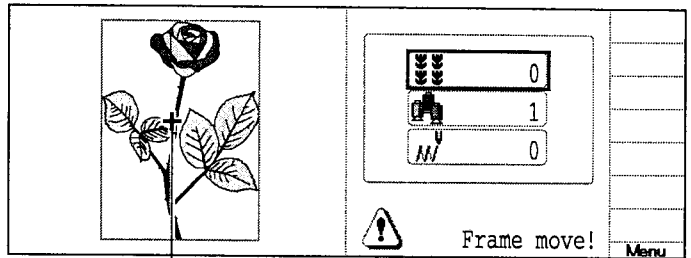

2. Press the **(SET)** button.

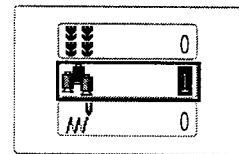

Pointer shows you the current position of the frame.

3. Select  with  and press **(SET)**.



4. Press up/down of  to select the number and press right/left of  to select the digit.

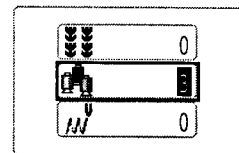

5. Press the **(SET)** button.
The frame moves to the selected color position.

CAUTION: To prevent accidents.
The frame moves quickly.
Keep hands away from the frame.

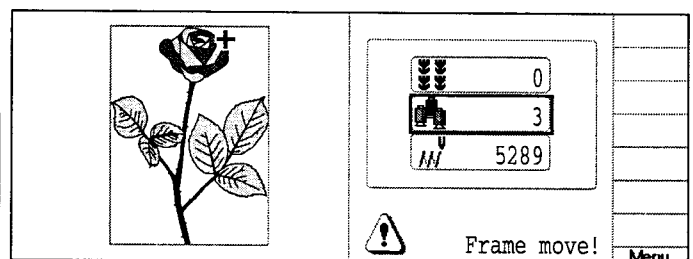

Press **(ESC)** to return to Menu mode.
Press **(ESC)** once again to return to Drive mode.

DISPLAYING THE PATTERN IN SETTING MODE 10-1

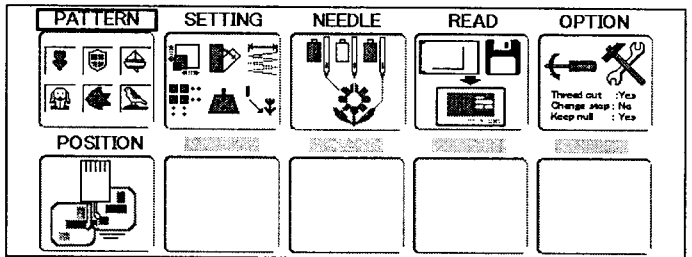

When there is  shows on the right side menu, the pattern data may be shown on the screen.

1. When the machine is stopped, press **(MENU)** and select desired setting item with .

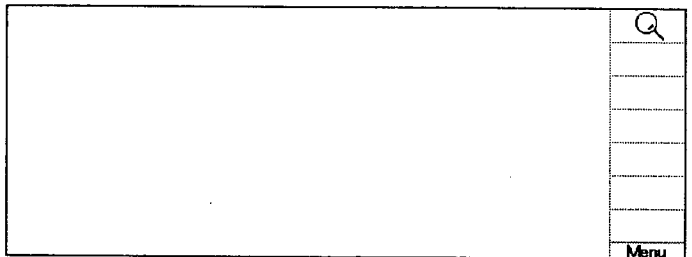

2. Press the **(SET)**.
Icon of  will be shown in sub-menu.



3. Press the **(MENU)** and select  with .

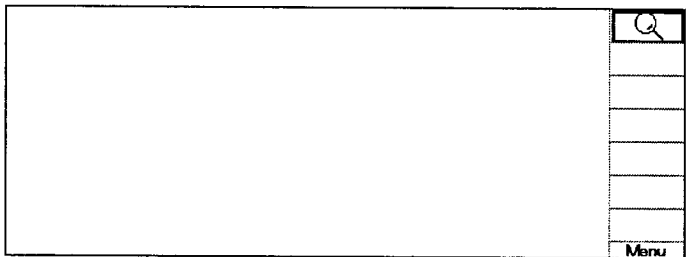

4. Press the **(SET)**.
Illustration of the pattern selected will be displayed.
Right side of display shows the detail information of the current pattern data.

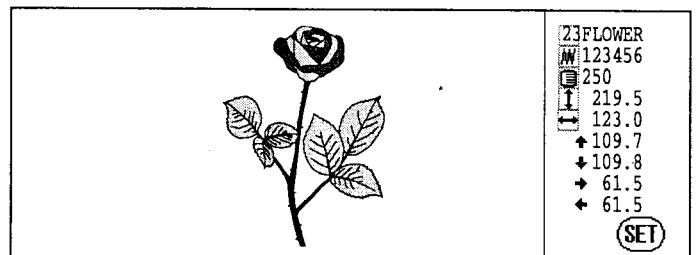

5. Press the **(SET)**.
The display returns to the view of Step 2.

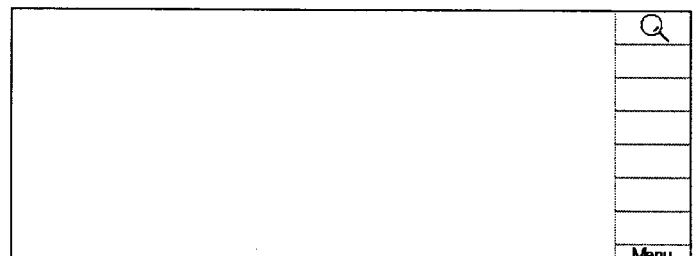

Press **(ESC)** to return to Menu mode.
Press **(ESC)** once again to return to Drive mode.

● Locking pattern data

Locking pattern data stored in the machine memory will prevent deletion and changes in settings.

1. When the machine is stopped, press **(MENU)** and Select "PATTERN" with .

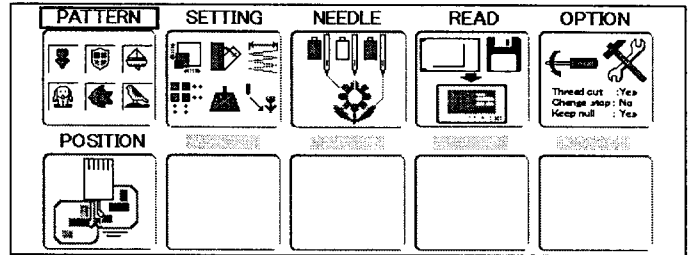

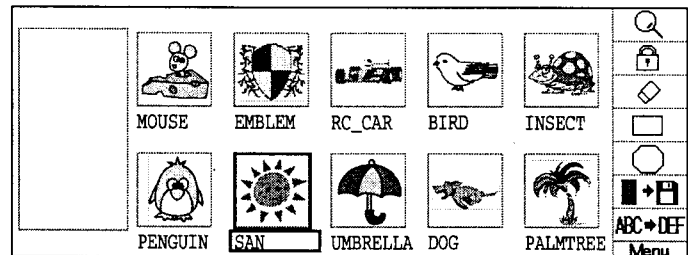

2. Press the **(SET)** button.

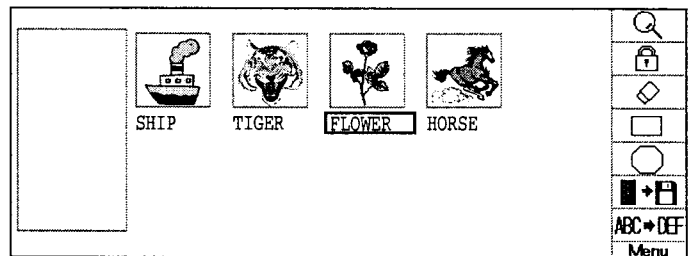

3. Select the pattern with .



4. Press the **(MENU)** and select  with .

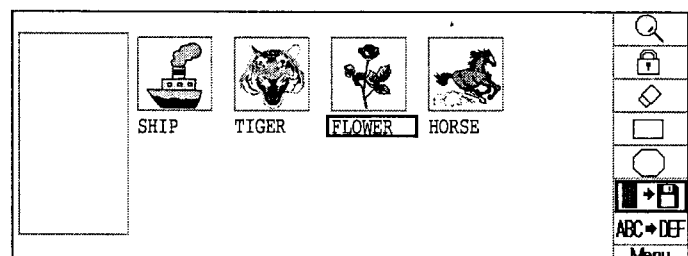

5. Press the **(SET)** button.

The symbol  will be shown on the left of the locked pattern.

Repeat steps 4 and 5 to unlock.

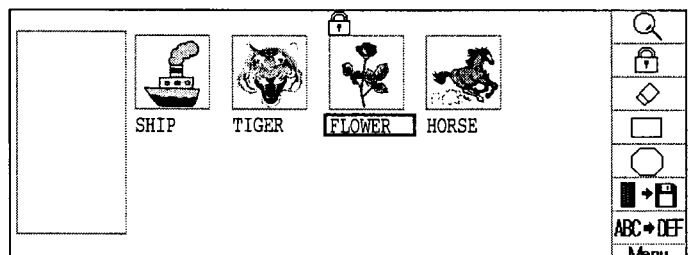

Press **(ESC)** to return to Menu mode.
Press **(ESC)** once again to return to Drive mode.

● Trace type

Changing the trace type of the pattern data in the machine memory. 14-5

1. When the machine is stopped, press **(MENU)** and select "PATTERN" with .

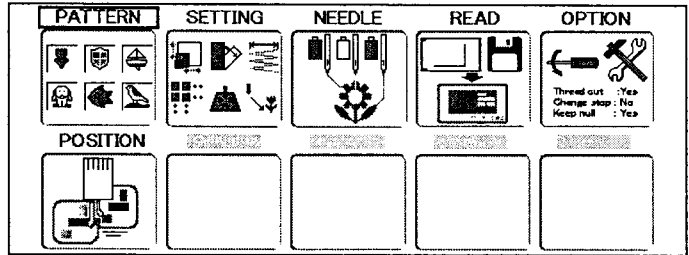

2. Press the **(SET)** button.

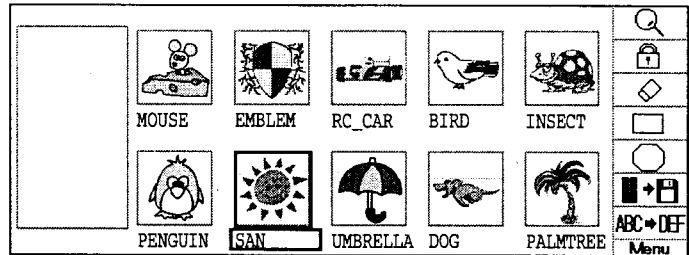

3. Select desired pattern with .

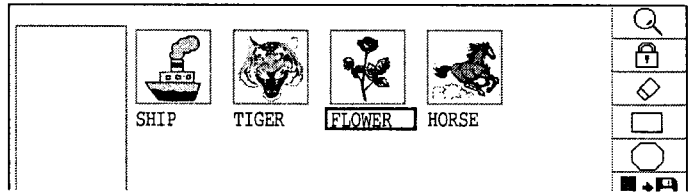

4. Press **(MENU)** and select or with .

Maximum embroidery area of pattern
 Outline of pattern

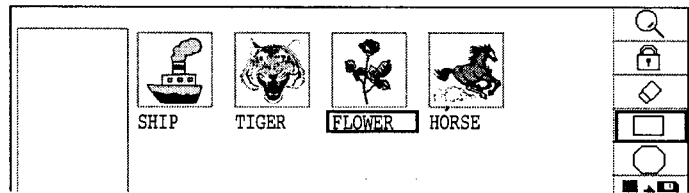

5. Press the **(SET)** button.
Trace type is changed.

--- Calculating ---

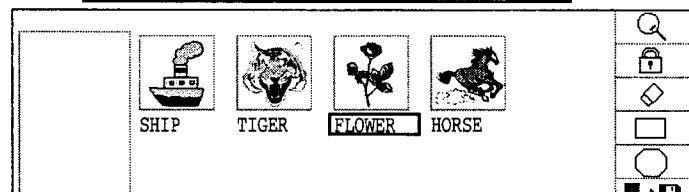

Press **(ESC)** and go back to Drive mode for confirmation.

Trace data

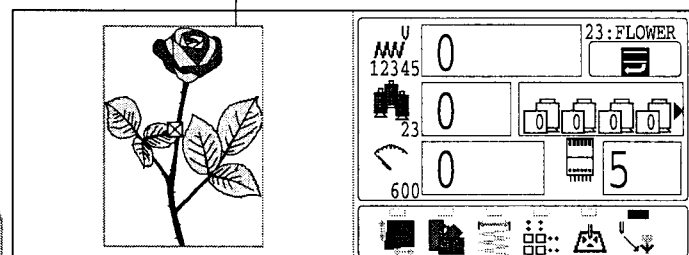

Press **(ESC)** to return to Menu mode.
 Press **(ESC)** once again to return to Drive mode.

● Renaming patterns

Rename pattern in memory.

- When the machine is stopped, press **(MENU)** and Select "PATTERN" with .

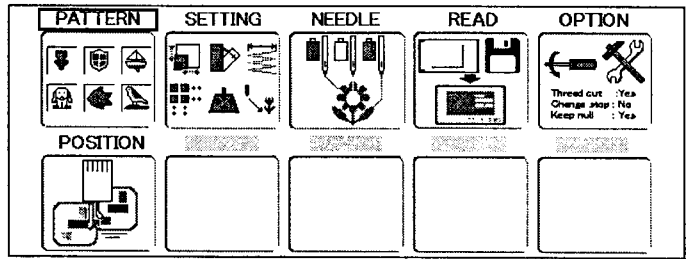

- Press the **(SET)** button.

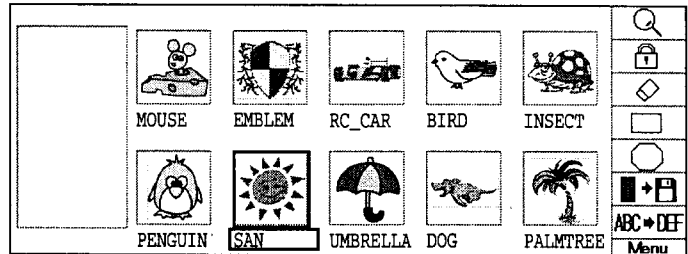

- Select desired pattern with .

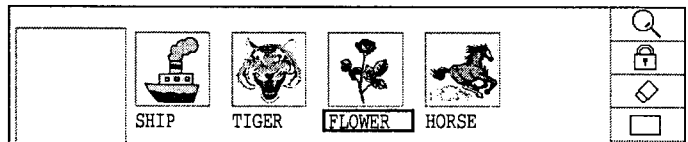

- Press **(MENU)** and select **ABC DEF** with .

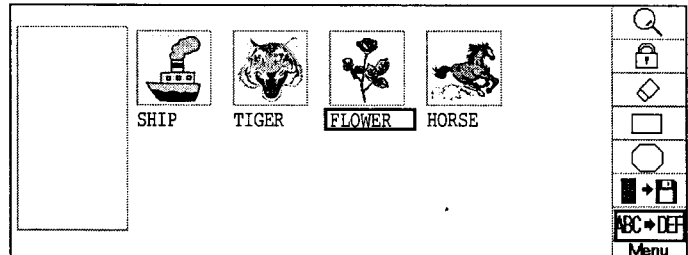

- Press the **(SET)** button.

- Choose "◀" or "▶" with  and press **(SET)**. Select each letter in the pattern name.

- ◀ To select digits on the left.
- ▶ To select digits on the right.

Pick a new name with  and press

(SET).

The maximum number of characters in a design name is eight letters or numbers.

- Select "END" with  and press **(SET)**. The pattern name will be changed.

Press **(ESC)** to return to Menu mode.

Press **(ESC)** once again to return to Drive mode.

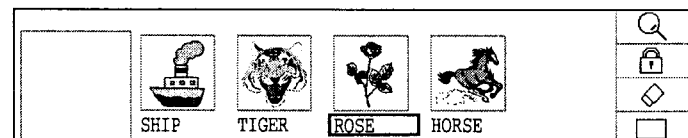
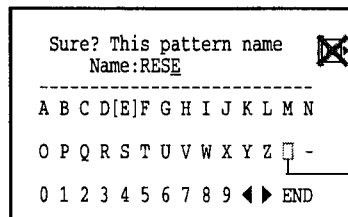
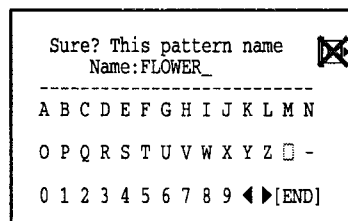

● Copying pattern data

Copying of the pattern data stored in the machine memory is available.

1. When the machine is stopped, press **(MENU)** and Select "PATTERN" with .

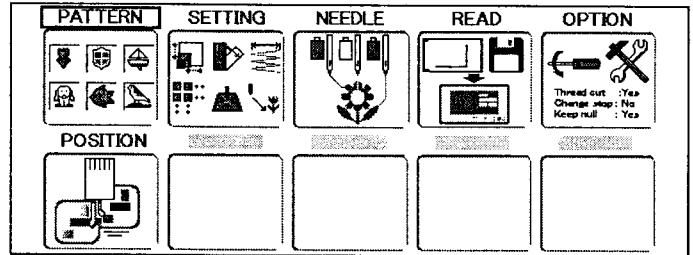

2. Press the **(SET)** button.

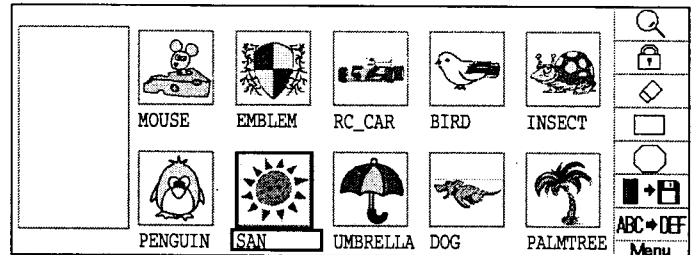

3. Select desired pattern with .

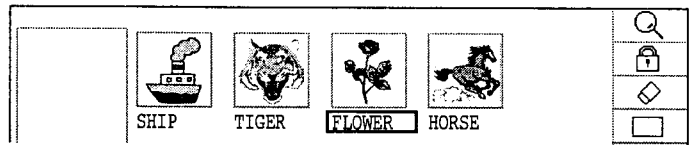

4. Press **(MENU)** and select  with .

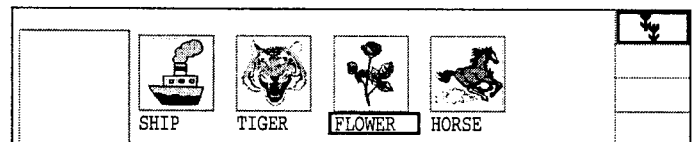

5. Press the **(SET)** button.
Copy of the selected pattern will be made.

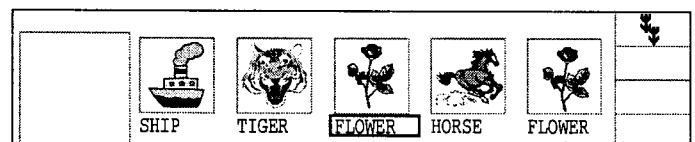

Copied pattern data

Press **(ESC)** to return to Menu mode.
Press **(ESC)** once again to return to Drive mode.

Various settings such as the scaling, repeat sewing, offset and frame out can be applied to a pattern.

Adjust

This menu contains settings such as scaling, width adjustment, angle and convert design.

Repeat sewing

The machine repeats the pattern a number of times in the X and Y directions as set by the user.

Offset

Sets the start point of the frame in the selected pattern.

Frame out

Inserts a frame out command in the selected pattern.

■ Various settings are executed in assortment.

● **Adjust**

Scaling

This adjusts the scale of the selected pattern.

Width adjustment

This adjusts the width of the selected pattern.

Angle

This adjusts the angle of the selected pattern.

Convert design

This sets the rotation of the selected pattern in increments of 90 degrees, normal or reversed.

Scaling

The pattern's scale can be increased or decreased in 1% increments.

Setting example

Normal

X 100 %, Y 150 %

Default : X,Y 100%

● : Start point of pattern

1. When the machine is stopped, press **MENU** and Select "SETTING" with

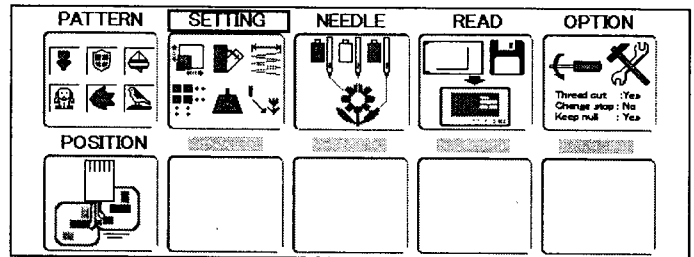

2. Press the **SET**.
The left side shows the number, name and details of the current pattern.

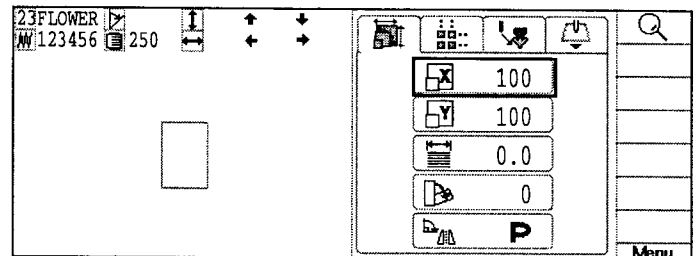

3. Press up/down of to select **X** or **Y** and time and press **SET**.

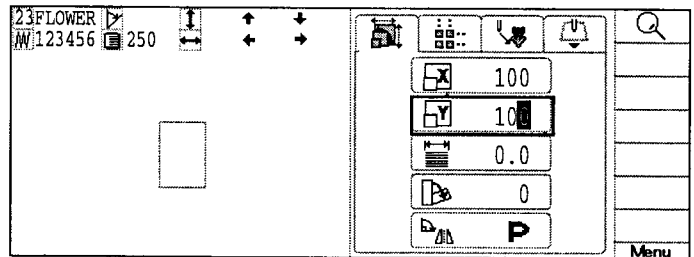

4. Press right /left of to select the digit and press up/down of to select the number.

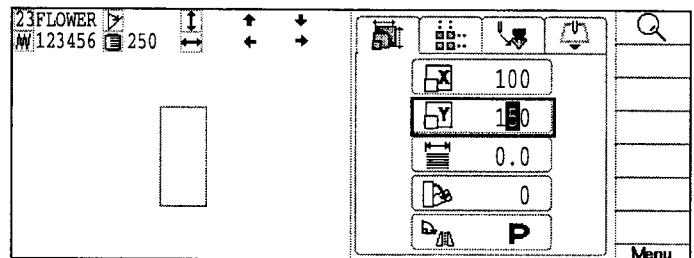

5. Press the **SET**.
The setting is fixed.

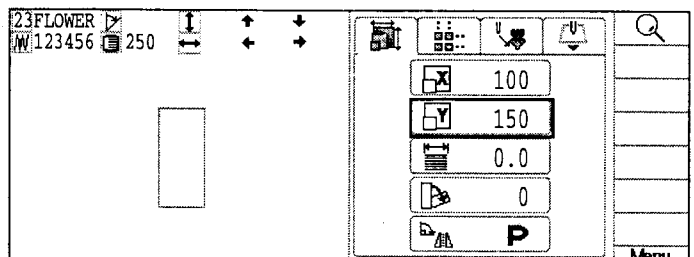

Press **ESC** to return to Menu mode.
Press **ESC** once again to return to Drive mode.

Width adjustment



This setting adjusts stitch width (L) in a pattern in a range of -1.0 ~ +1.0mm in increments of 0.1mm.

■ In case "Width" (Width adjustment) is set and embroidery is made, there is a case that error occurs at end point. In such a case, please return setting figure of stitch width to "0.0".

1. When the machine is stopped, press **MENU** and Select "SETTING" with .

2. Press the **SET**.
The left side shows the number, name and details of the current pattern.

3. Press up/down of  to select  and press **SET**.

4. Press right /left of  to select the digit and press up/down of  to select the number.

5. Press the **SET**.
The setting is fixed.

Press **ESC** to return to Menu mode.
Press **ESC** once again to return to Drive mode.

Setting example

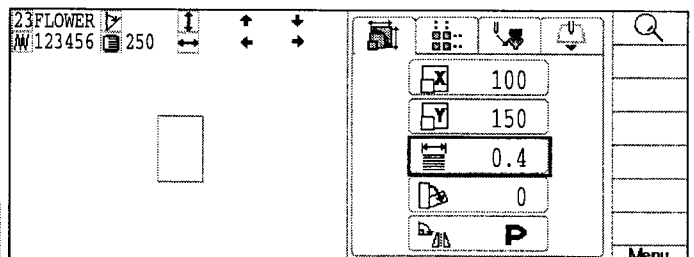
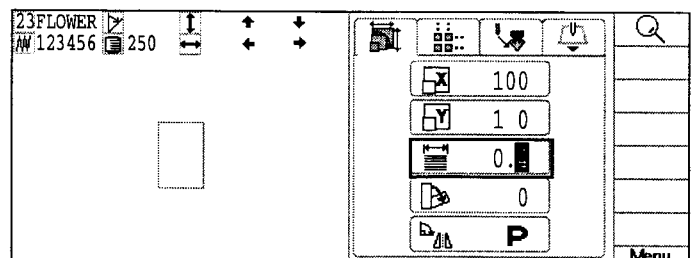
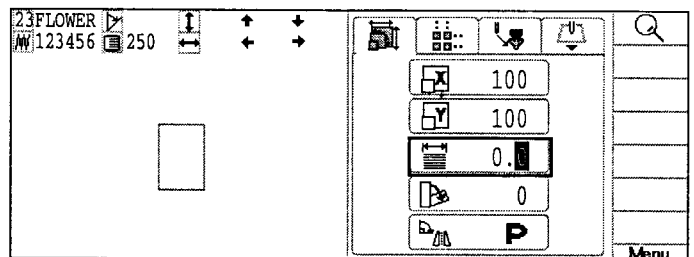
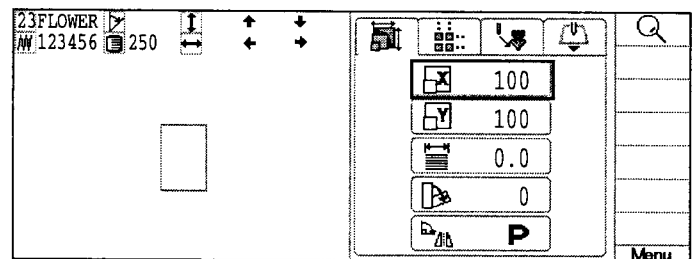
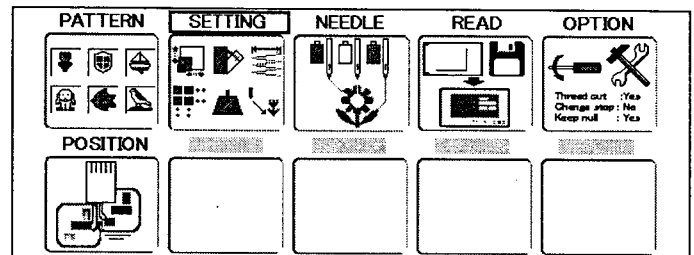
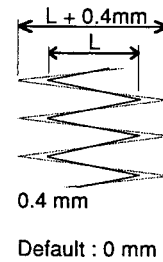

Angle

With the start point of the pattern as a pivot, the machine rotates the angle clockwise.

Setting example

R

Normal

Default : 0.

R
30.

● : Start point of pattern

- When the machine is stopped, press **MENU** and Select "SETTING" with .

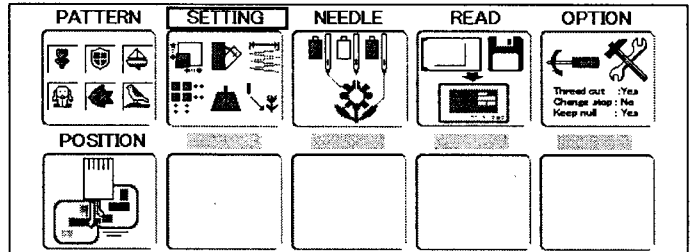

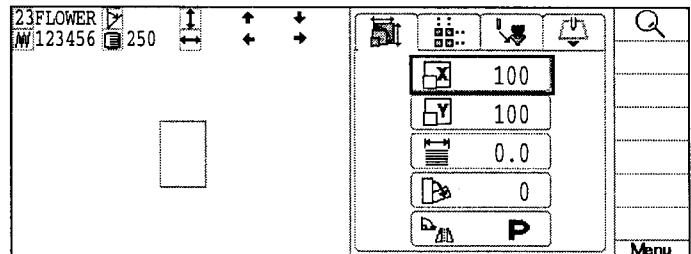

- Press the **SET**.
The left side shows the number, name and details of the current pattern.

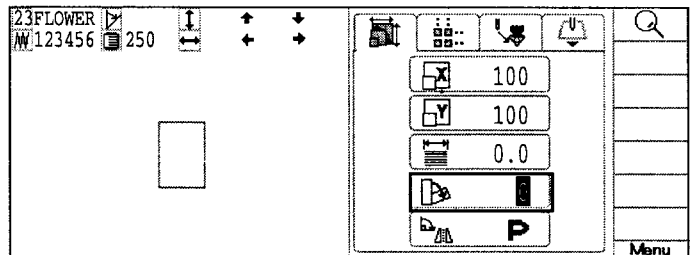

- Press up/down of  to select  and press **SET**.



- Press right /left of  to select the digit and press up/down of  to select the number.

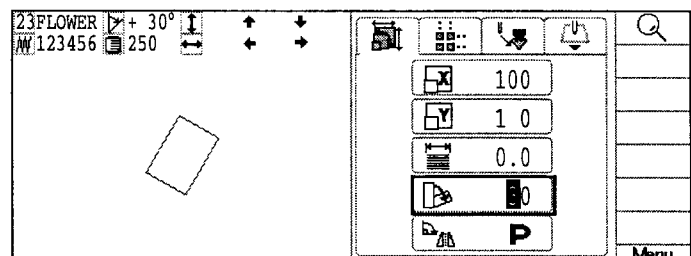

- Press the **SET**.
The setting is fixed.

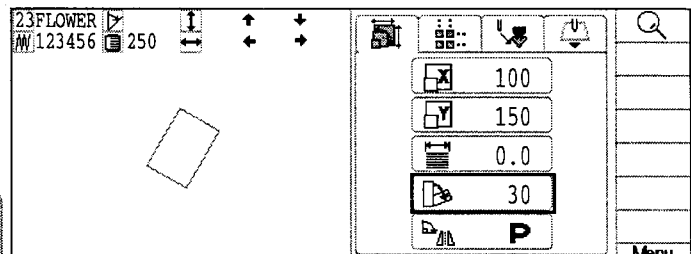

Press **ESC** to return to Menu mode.

Press **ESC** once again to return to Drive mode.

● Repeat sewing

The machine embroiders a user-specified number of copies in the X and Y directions.

Setting example

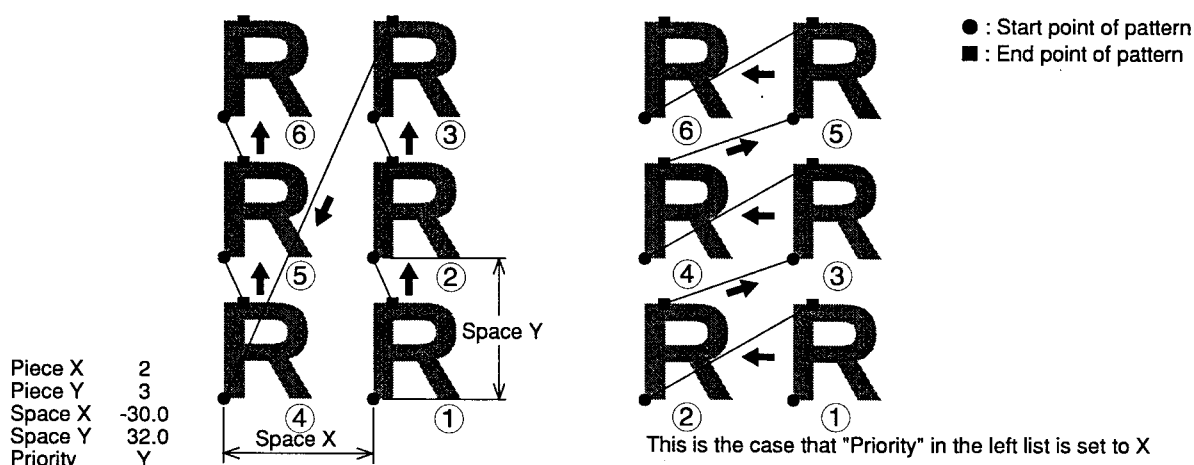



SETTING ITEM	SETTING RANGE	DEFAULT	
Piece X	1 ~ 30	1	This sets number of pieces side wise and length wise when you perform repeat.
Piece Y	1 ~ 30	1	The number of pieces to be embroidered is product obtained by multiplying numbers in X and Y.
Space X	-999.9 ~ 999.9 mm	0	This sets side wise distance between start point of each pattern when you perform repeat. When plus number is input, the machine makes repeat toward right. In case of minus number, toward left.
Space Y	-999.9 ~ 999.9 mm	0	This sets length wise distance between start point of each pattern when you perform repeat. When plus number is input, the machine makes repeat upward. In case of minus number, downward.
Priority	X (Side) • Y (Length)	X	When you set more than 2 pieces for repeat length wise and side wise, this selects direction to embroider 2nd piece.

PATTERN SETTINGS

12-6

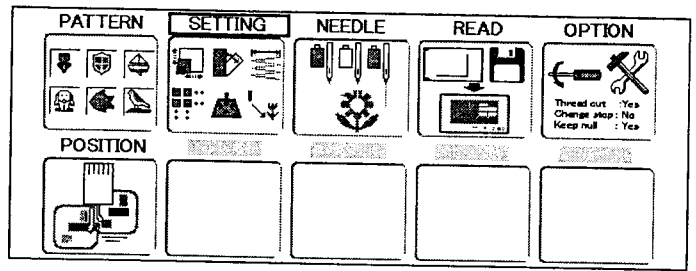
- When the machine is stopped, press **MENU** and Select "SETTING" with .



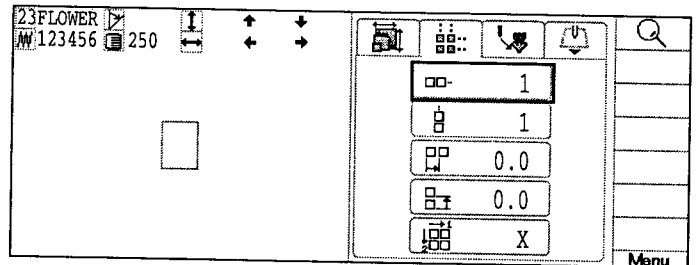

- Press **SET** and press right /left of  to select . The left side shows the number, name and details of the current pattern.

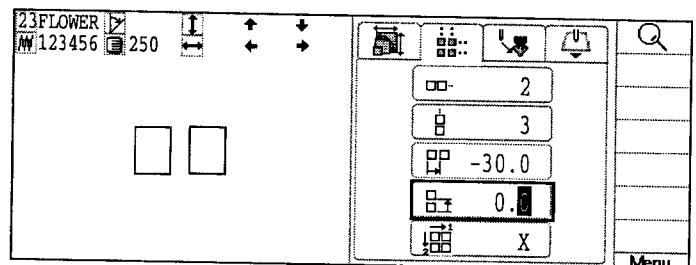

- Press up/down of  to select the item and press **SET**.



- Press right /left of  to select the digit and press up/down of  to select the number.

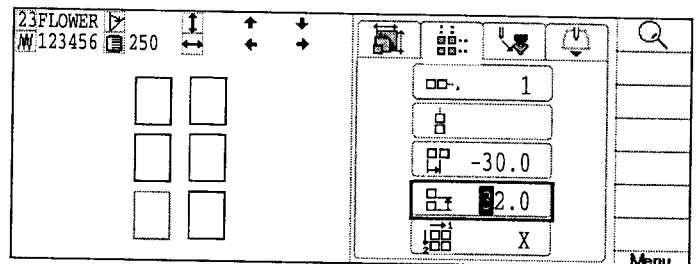

- Press the **SET** button. The setting is fixed.

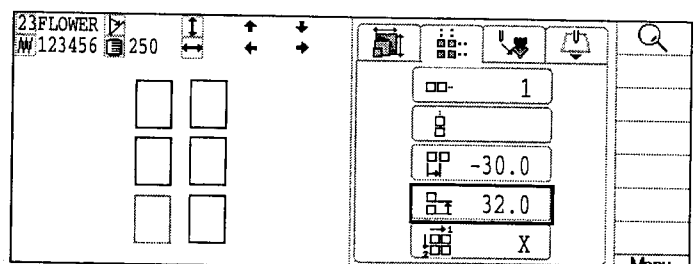

- Set necessary item by performing procedure no. 3 to no.5. Set all the necessary items.

Press **ESC** to return to Menu mode.
Press **ESC** once again to return to Drive mode.

● Auto origin

When a pattern has different start and end points, the frame returns to the original point

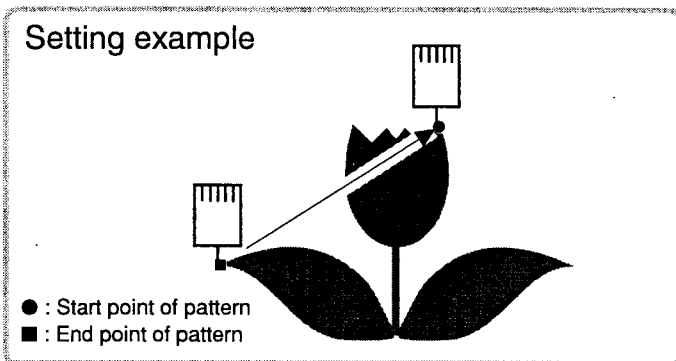

1. When the machine is stopped, press **(MENU)** and Select "SETTING" with

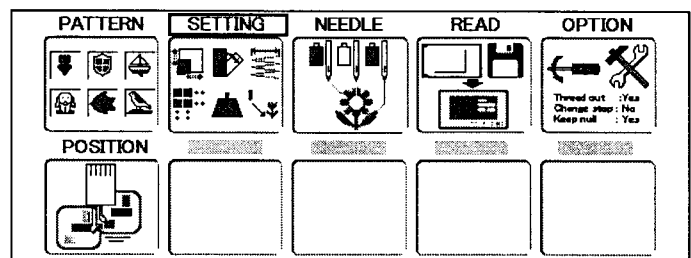

2. Press **(SET)** and press right /left of to select
- The left side shows the number, name and details of the current pattern..

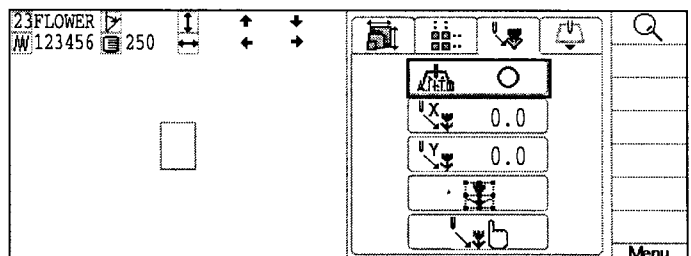

3. Press up/down of to select (Auto origin) and press **(SET)**.

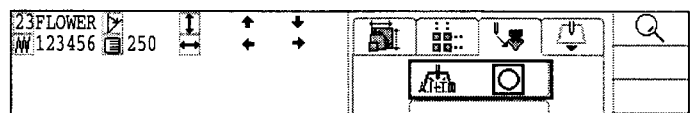

4. Press up/down of to select (ON) or (OFF).

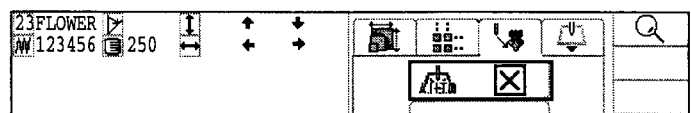

5. Press the **(SET)** button.
The setting is fixed.

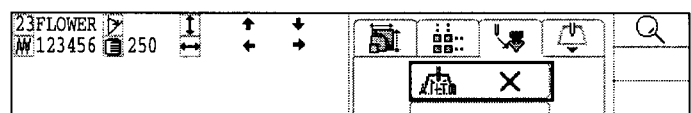

Press **(ESC)** to return to Menu mode.
Press **(ESC)** once again to return to Drive mode.

● Offset

Setting the offset point designates a place for the frame to rest before moving to the start point of the actual embroidery.

When used together with the auto origin feature, the machine will return to the offset when it is finished embroidering as well.

This allows you to send the frame to a place where it will be easier to handle, when you will need to change hoops for example.

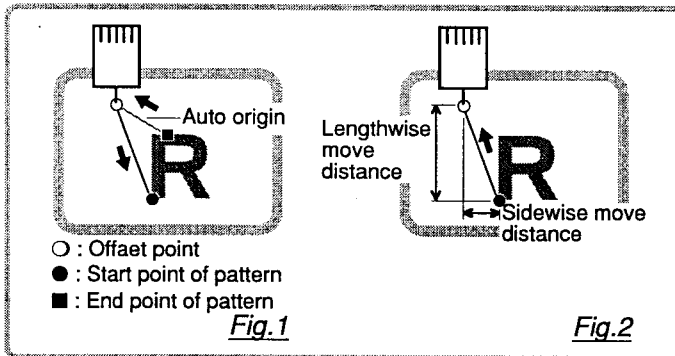

Direct input

You can move the offset point manually and save the position with "Teaching input".

Preset

There are 9 preset points that can be used for offsets around and in the center of the pattern.

Teaching input

You can set the offset point manually.

- When you press the **ORG** (Original point return) or use *auto origin with an offset, the frame will return to the offset point. 12-7
- Make sure *auto origin is activated when you are using the offset function repeatedly on the same pattern. 12-7

Direct input

You can move the offset manually and save the position with "teaching input".

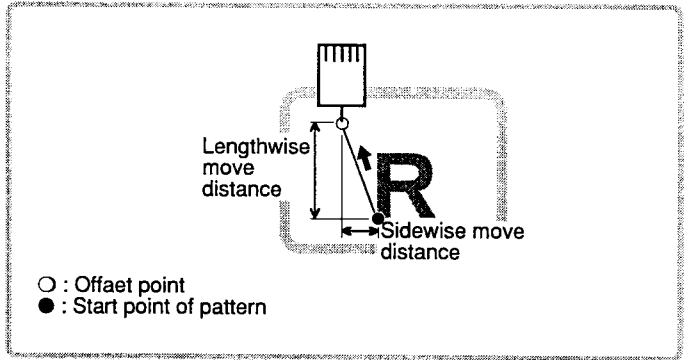

1. When the machine is stopped, press **(MENU)** and Select "SETTING" with

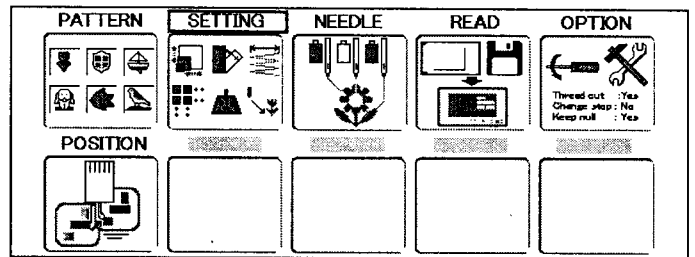

2. Press **(SET)** and press right /left of to select

The left side shows the number, name and details of the current pattern.

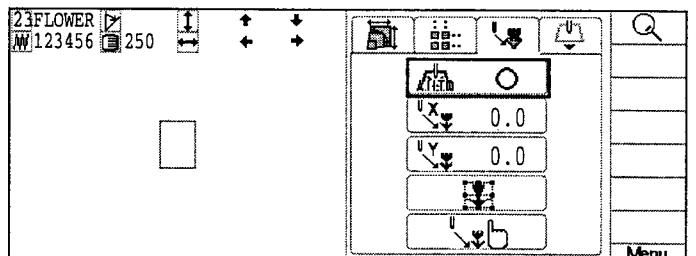

3. Press up/down of to select (X axis distance) or (Y axis distance) and press **(SET)**.

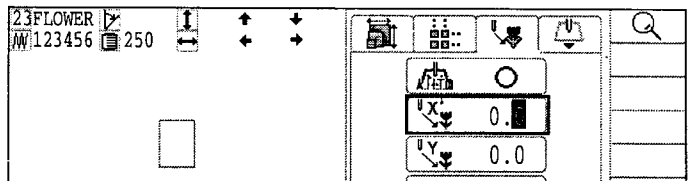

4. Press right /left of to select the digit and press up/down of to select the number.

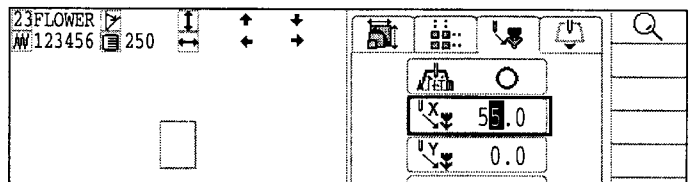

5. Press the **(SET)** button.
The setting is fixed.

Press **(ESC)** until the display returns to drive mode.

will appear at the lower right in green.

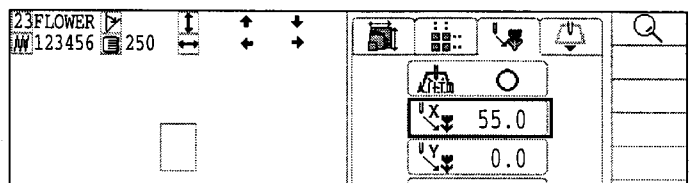

Offset point

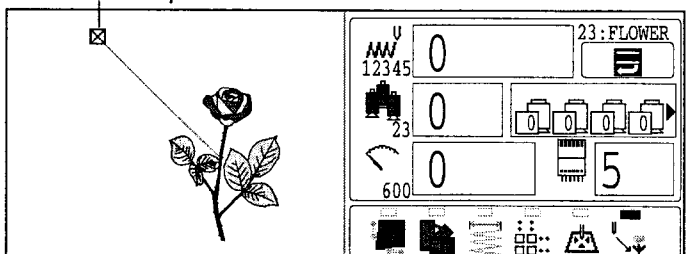

Press **(ESC)** to return to Menu mode.



Press **(ESC)** once again to return to Drive mode.

Preset

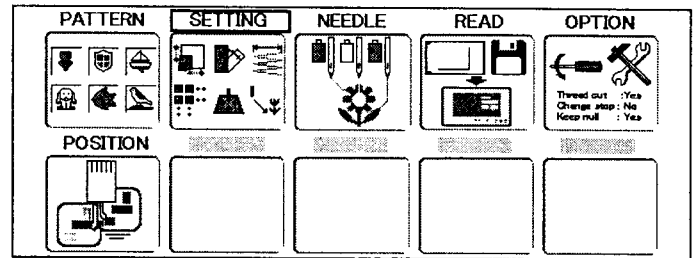

There are 9 preset points that can be used for offsets around the or in the center of the pattern.

1. When the machine is stopped, press **(MENU)** and Select "SETTING" with .

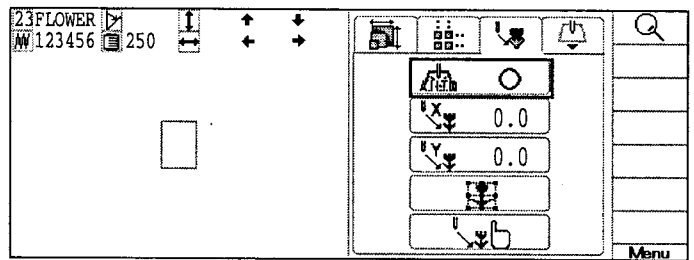

2. Press **(SET)** and press right /left of  to select . The left side shows the number, name and details of the current pattern.



3. Press up/down of  to select  and press **(SET)**.

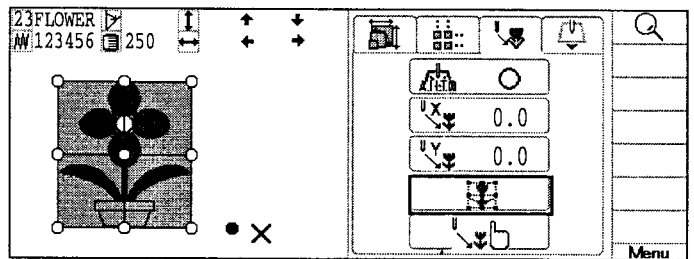

4. Select the offset point with  and press **(SET)**. The setting is fixed.

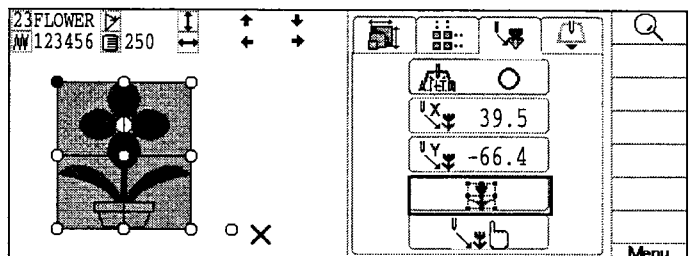

Press **(ESC)** until the display returns to drive mode.

 will appear at the lower right in green

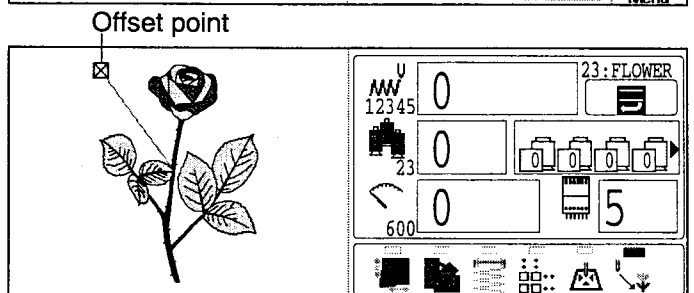

Press **(ESC)** to return to Menu mode.
Press **(ESC)** once again to return to Drive mode.



PATTERN SETTINGS

12-B

Teaching input

You can set the offset position manually.

1. When the machine is stopped, press **MENU** and Select "SETTING" with .

2. Press **SET** and press right /left of  to select .
The left side shows the number, name and details of the current pattern.

3. Press up/down of  to select  and press **SET**.

4. Use the  to move the frame to the offset point.

5. Press the **SET** button.
The setting is fixed.

6. Use the  to move the frame to the offset point.

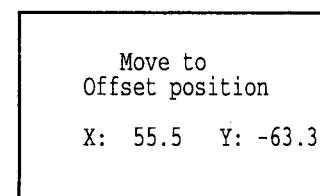
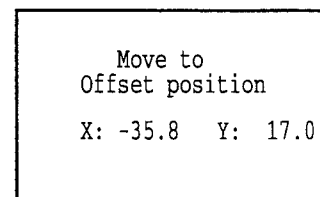
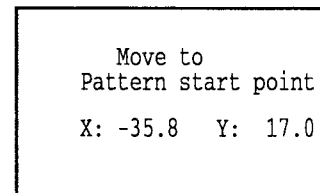
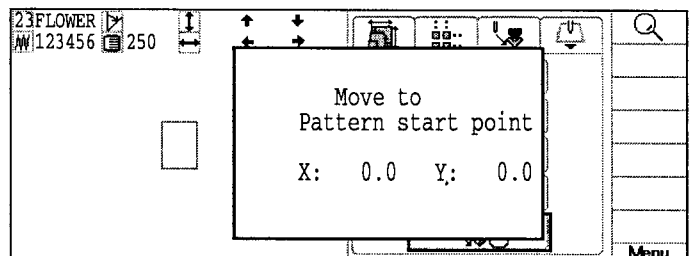
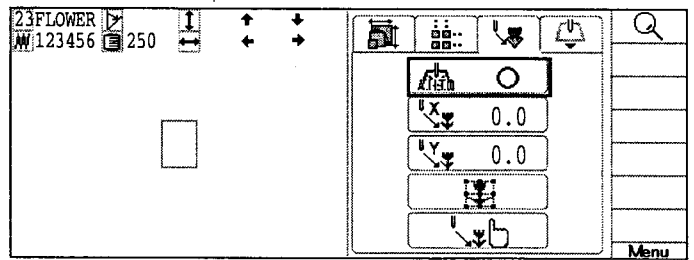
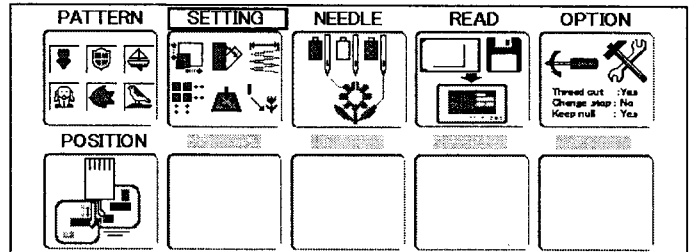
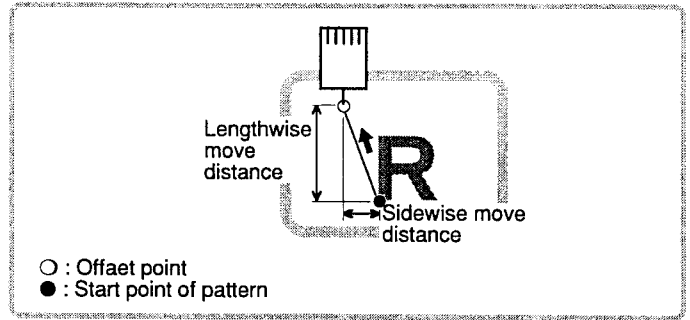

PATTERN SETTINGS

12-C

7. Press the **SET** button.
The setting is fixed.

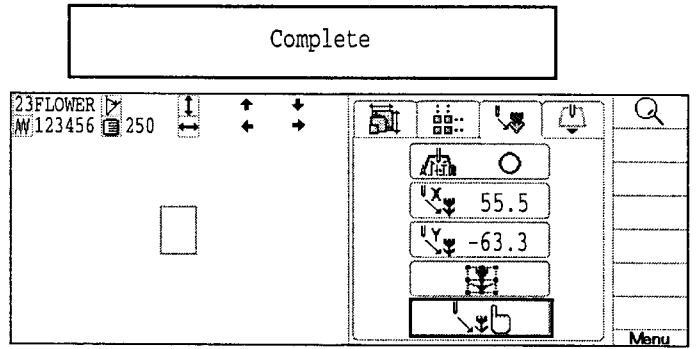

Press **ESC** until the display returns to drive mode.

 will appear at the lower right in green.

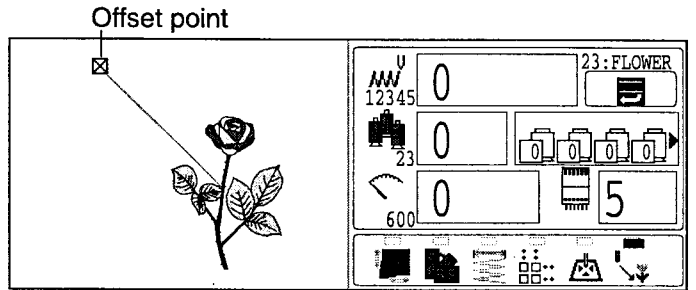

Press **ESC** to return to Menu mode.

Press **ESC** once again to return to Drive mode.

●Frame out

A frame out command can be added to a design. By setting frameout to a *Color change number in a design, you can move the frame to a desired position automatically and stop it after the machine finishes sewing of that color change number.

When you resume operation, the frame has an automatic return to previous position and you can continue sewing. (Fig.1)

This function will be convenient for trimming threads while embroidering or for sewing applique etc.

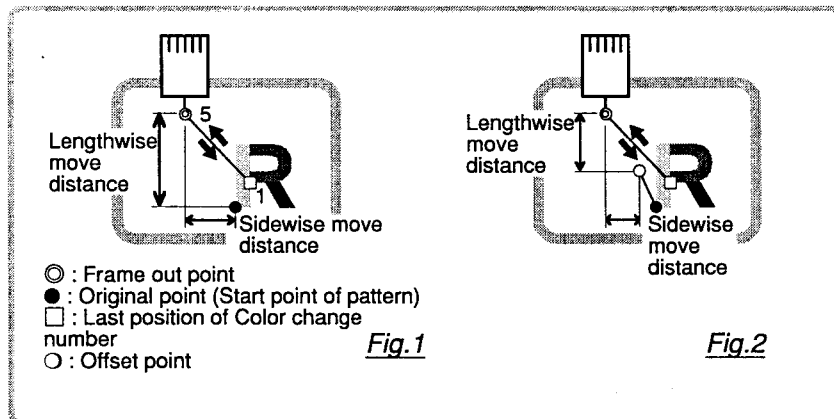

Selection of color change number

Set Color change number to execute frameout.

- When you select "Off" (with no display of option) of frame out for Color change number to which *color change stop is set, color change stop is released.
- When you turn frameout "On" without setting the move distance of frameout, this results in the same action as color a change stop.

Teaching input

Set position of frame out with  and the distance of movement will be the frame out distance.

Usually move distance to frame out point is input, with original point as pivot.(Fig.1)

In case offset is set, the move distance is input with offset point as pivot.(Fig.2)

- You can set number of stitches or Color change number to make frame out in plural, but frame out point is limited to one place. The point set finally becomes good for making frame out. The point set finally becomes good for making frame out.

Direct input

You can set the position of frame out directly by inputting by the number keys. You can also change the position of a frame out set by "Teaching input".

Normally, the distance to the frameout point is input with the original point as a pivot. (Fig. 1) In case where an offset is set, the move distance to frameout position is input with offset point as pivot. (Fig.2)

PATTERN SETTINGS

12-E

Execution of color change number

Set Color change number to execute frameout.

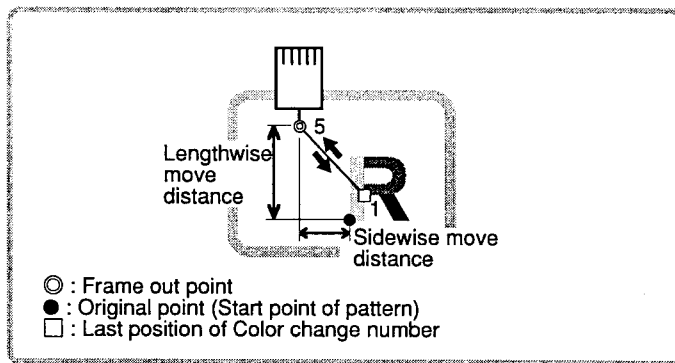

1. When the machine is stopped, press **(MENU)** and Select "SETTING" with

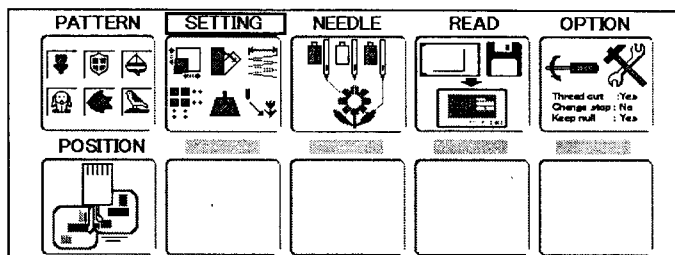

2. Press **(SET)** and press right/left of to select

The left side shows the number, name and details of the current pattern.

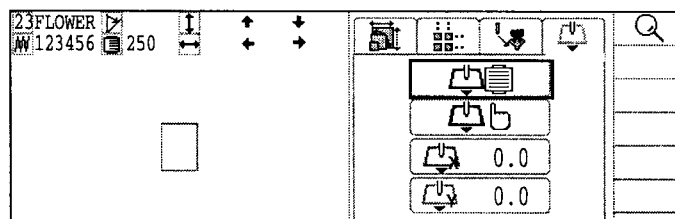

3. Press up/down of to select and press **(SET)**.

The current color number is shown in the pattern data display portion.

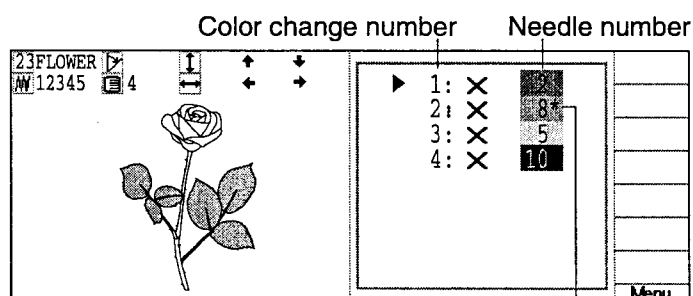

The color change stop mark "*" is showed.

4. Press up/down of to select the Color change number and press **(SET)**.

The setting is fixed.

○ (on) will be shown to the right of the color change number.

◆ (on) will be shown to the right of the needle number.

If you press the **(SET)** you can alternate between

○ (on) and X (off).

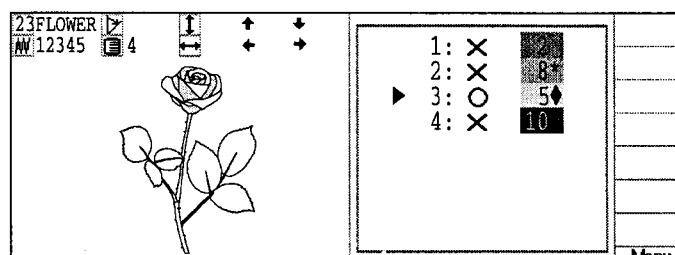

Press **(ESC)** to return to Menu mode.

Press **(ESC)** once again to return to Drive mode.

PATTERN SETTINGS

12-F

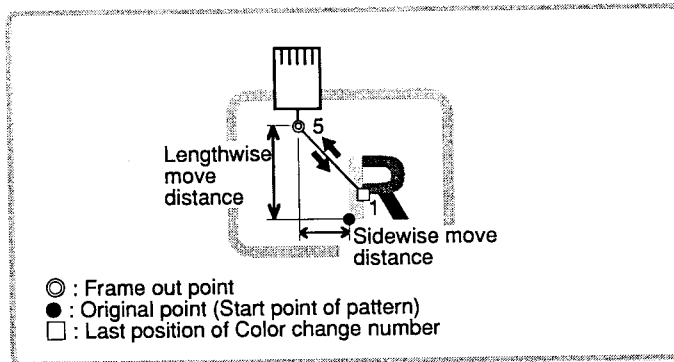

Teaching input

Move the frame with  and the position will be saved as the frame out.



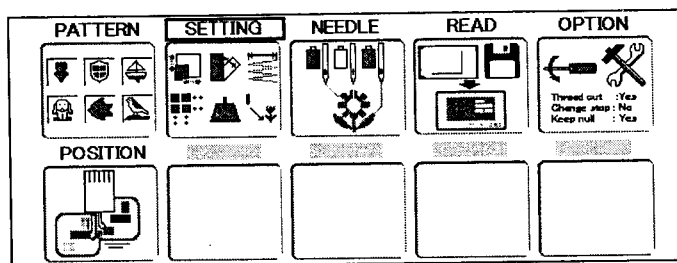

1. When the machine is stopped, press **MENU** and Select "SETTING" with .



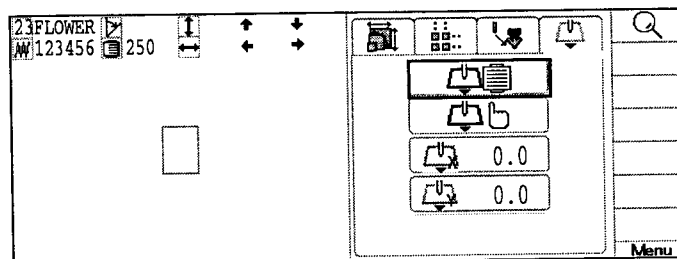

2. Press **SET** and press right/left of  to select .

The left side shows the number, name and details of the current pattern.

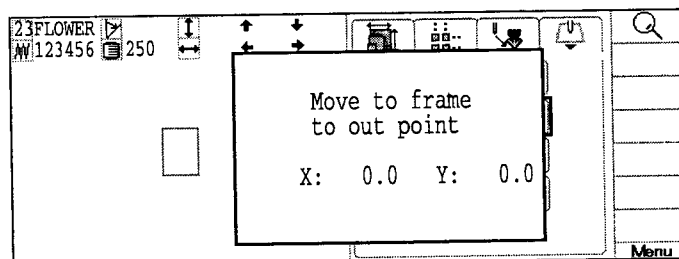

3. Press up/down of  to select  and press **SET**.



4. Use the  to move the frame to the frame out position.

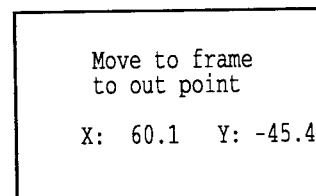

5. Press the **SET**.
The setting is fixed.

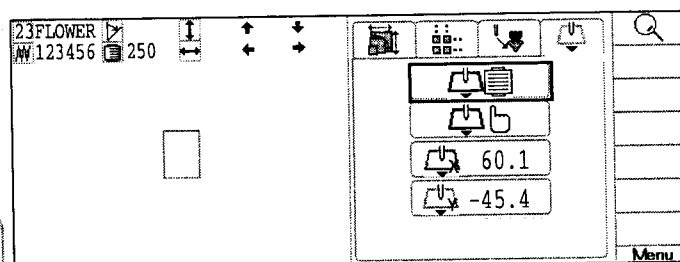

Press **ESC** to return to Menu mode.
Press **ESC** once again to return to Drive mode.

Direct input

You can change the position of your frame out by using this function. You can change the moving distance of the frame out and change the frame out position, which is saved by "Teaching input".

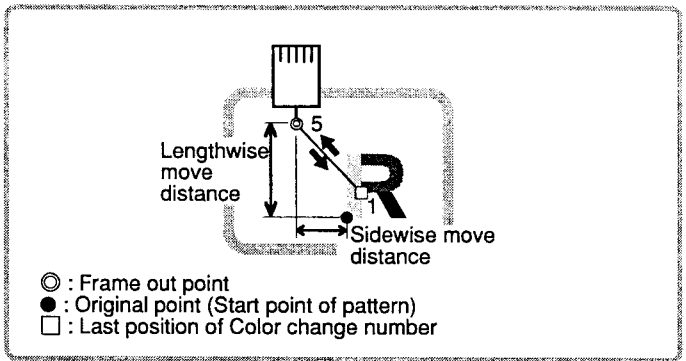

1. When the machine is stopped, press **(MENU)** and Select "SETTING" with

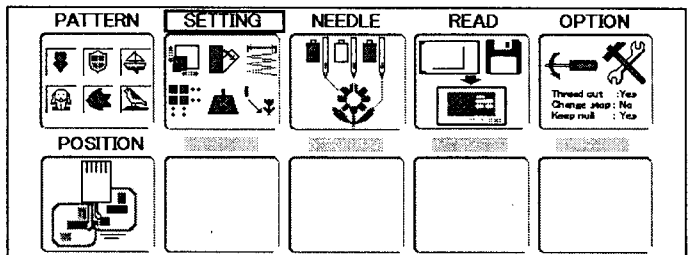

2. Press **(SET)** and press right /left of to select

The left side shows the number, name and details of the current pattern.

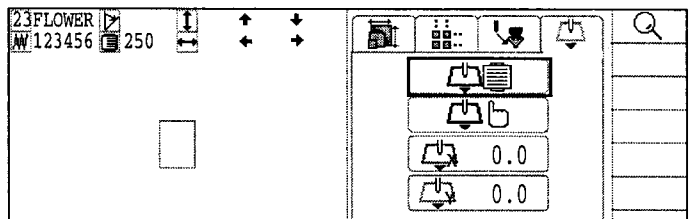

3. Press up/down of to select (X axis distance) or (Y axis distance) and press **(SET)**.

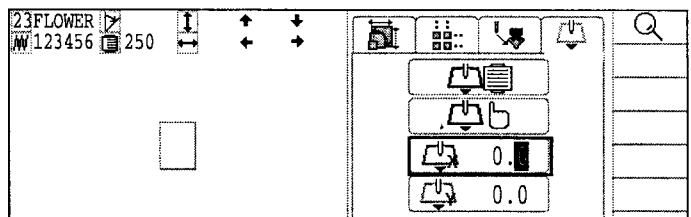

4. Press up/down of to select the number and press right /left of to select the digit.

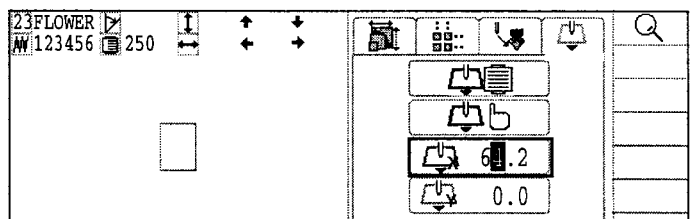

5. Press the **(SET)** button.
The setting is fixed.

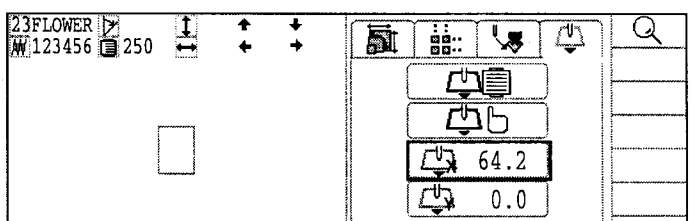

Press **(ESC)** to return to Menu mode.
Press **(ESC)** once again to return to Drive mode.

Needle number settings 5-E

A needle number can be assigned to a *color change number.

When the needle number is assigned, the machine will embroider and automatically switch to the programmed for each color change number.

Color change stop function 5-F

A *color change stop can be assigned to a color change number.

When this is done, the machine embroiders the stitches for that color change number and then stops, displaying the following message:

>>Change Stop

Auto setting

Changes all designated needle numbers at once.

Color change data registration, Color change data read

You can use the color change data from a saved pattern, register it, and then export the registered data to the selected pattern for use.

● Auto setting

This changes all designated needle numbers at once.

For example, if you want to change all needles numbered "10" to "6", just select one of the color change numbers in which "10" is set, then all color change numbers can be changed into "6".

1. When the machine is stopped, press **(MENU)** and Select "NEEDLE" with .

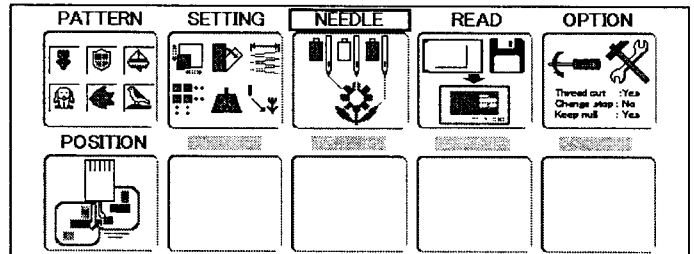

2. Press the **(SET)** button.
The left side shows the number, name and details of the current pattern.

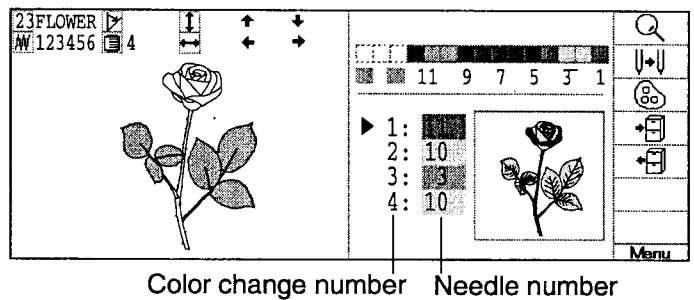

3. Press **(MENU)** and select  with .

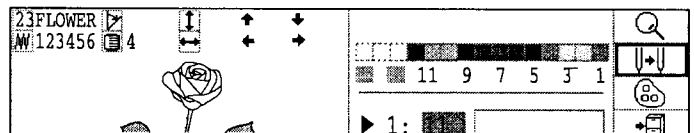

4. Press the **(SET)** button.

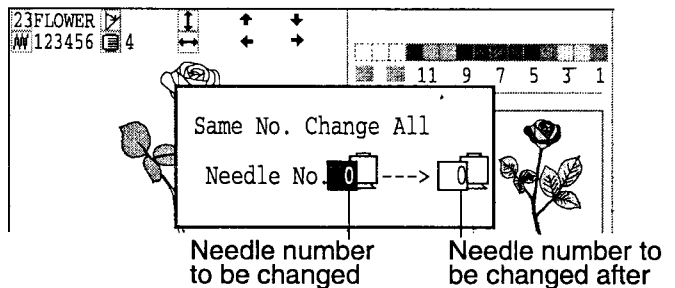

5. Select the current needle number you would like to change with  and press **(SET)**.

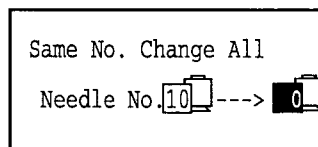

6. Select the needle number to be changed with .

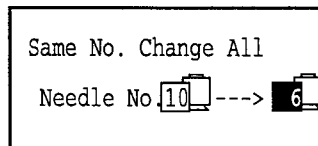

7. Press the **(SET)** button.
The setting is fixed.

Press **(ESC)** to return to Menu mode.
Press **(ESC)** once again to return to Drive mode.

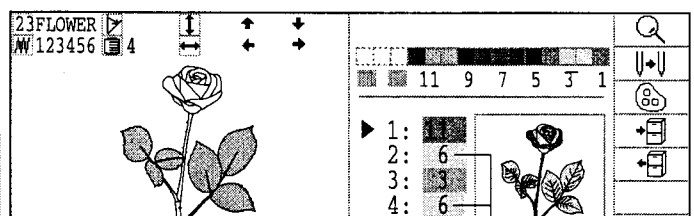

The needle number has been changed from 10 to 6.

NEEDLE BAR SELECTION

13-3

● Thread color

This sets the background color or color assigned to each needle bar to be shown in the display. This is useful to help confirm the correct color setup of a pattern. (128 colors are available)

■ You will find difficulty to see the pattern if you set same color on both pattern and background.

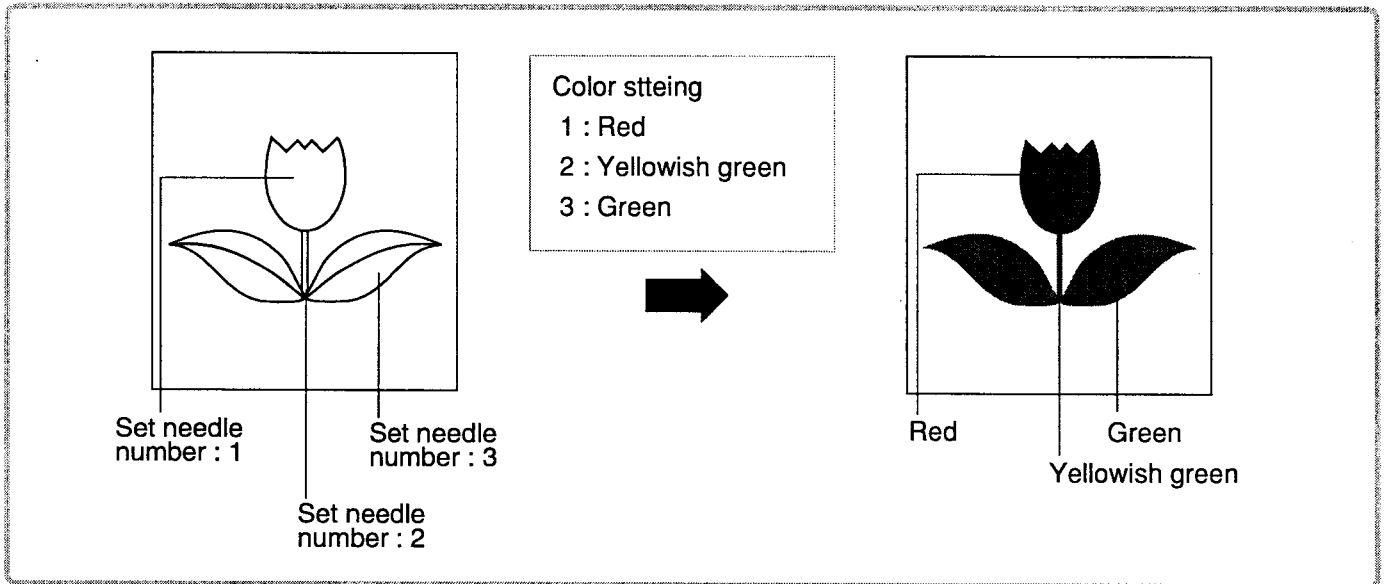

1. When the machine is stopped, press **MENU** and Select "NEEDLE" with

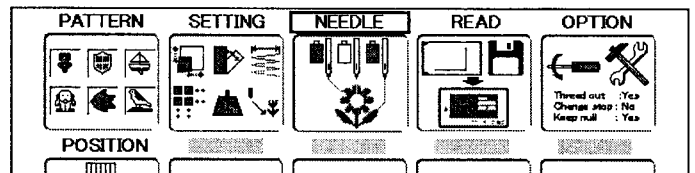

2. Press the **SET** button.
The left side shows the number, name and details of the current pattern.

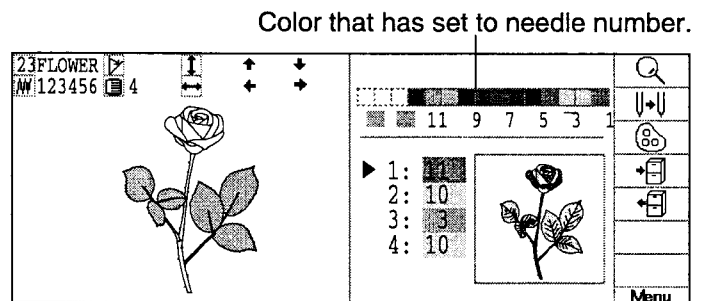

3. Press **MENU** and select with

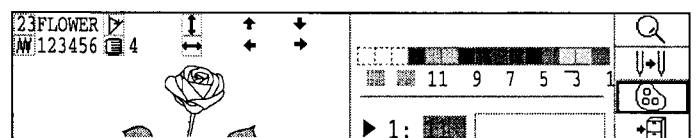

4. Press the **SET** button.

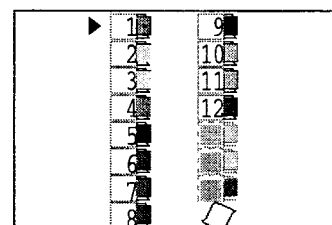

NEEDLE BAR SELECTION

13-4

5. Select the needle number or cloth (background color) with .

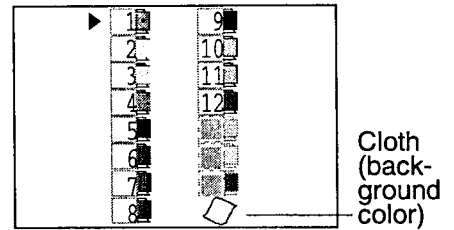

6. Press the **SET** button.
The current color will be shown on the left.
Color preview will be shown on the right.

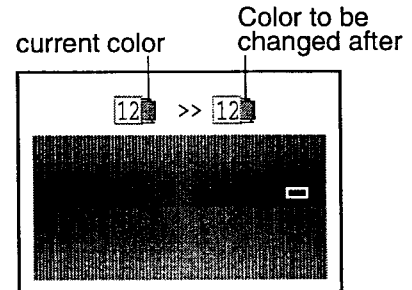

7. Select the color to be changed with .
- Current color will be shown on the right.

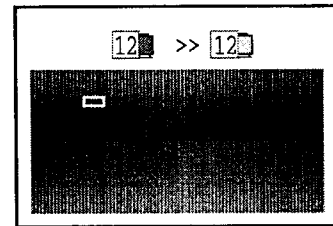

8. Press the **SET** button.
The setting is fixed.

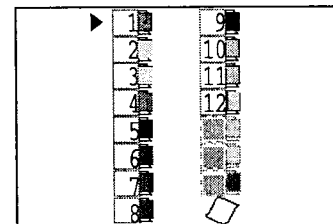

9. Press the **ESC** button.
Confirm the colors shown in the preview display.

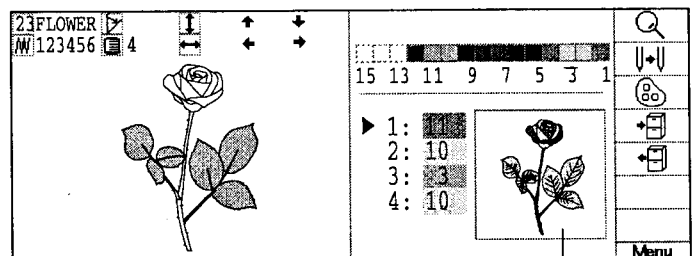

Preview

Press **ESC** to return to Menu mode.
Press **ESC** once again to return to Drive mode.

● Color change data registration

You can import and apply color change data from saved patterns (Including color change stops) to the current pattern. This function lets you apply the same color change data from other patterns.

■ The color change data is limited to one and the color change numbers are limited to 250.

1. When the machine is stopped, press **(MENU)** and Select "NEEDLE" with .



2. Press the **(SET)** button.
The left side shows the number, name and details of the current pattern.

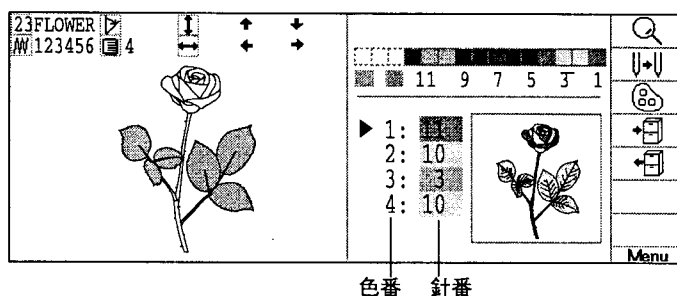

3. Press **(MENU)** and select  with .

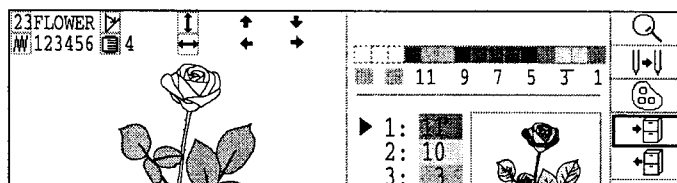

4. Press the **(SET)**.
The color change data will be saved into memory.

Needle entry

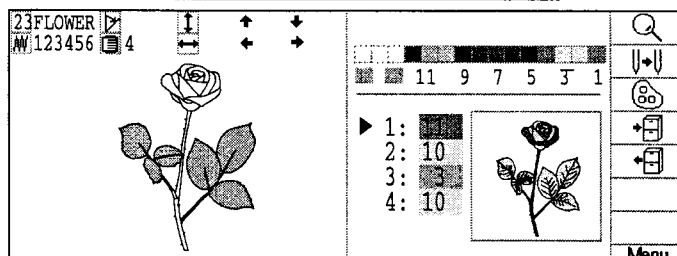

Press **(ESC)** to return to Menu mode.
Press **(ESC)** once again to return to Drive mode.

● Color change data read

You can export the registered color change data to other patterns.

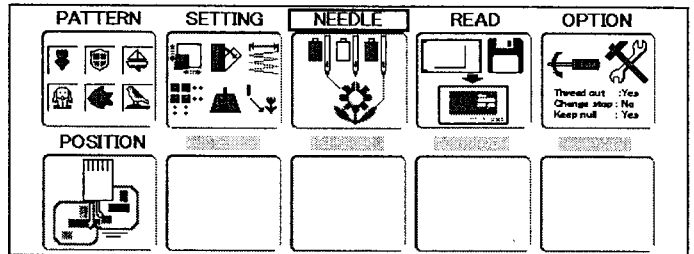

- If the pattern receiving the imported color change data has more color changes than the imported data, the extra color changes will be set to "0" and will need to be set manually later.

1. When the machine is stopped, press **(MENU)** and Select "NEEDLE" with .

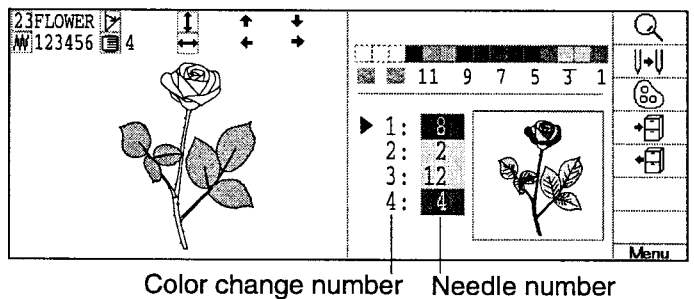

2. Press the **(SET)** button.
The left side shows the number, name and details of the current pattern.



3. Press **(MENU)** and select  with .

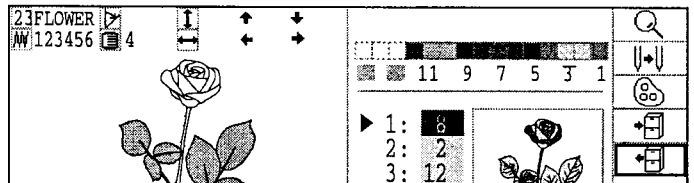

4. Press the **(SET)** button.
The needle number set is subject to the color change data exported.
Confirm the color shown in the preview display.

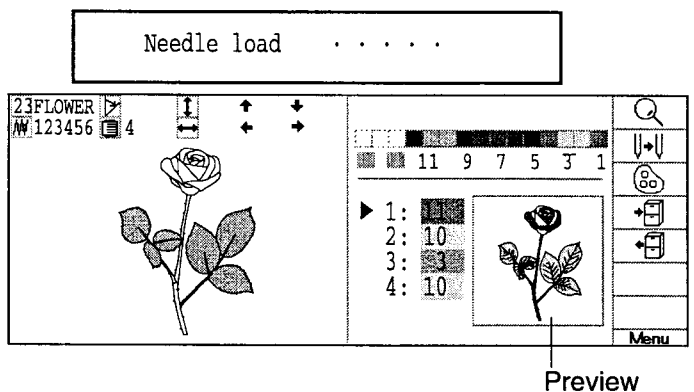

Press **(ESC)** to return to Menu mode.
Press **(ESC)** once again to return to Drive mode.

● Pattern read settings

Settings related to pattern data reading:

SETTING ITEM	SETTING RANGE	
1 Keep null (CHG.)	No•Yes	: This function lets the machine read zero stitches as they are before color change when reading pattern data.
2 Skip null stitch	No•Yes	: This lets you choose to ignore all null stitches when reading pattern data.
3 Combine jump	No•Yes	: Allows you to combine multiple, consecutive jump stitches when reading pattern data, if desired. It combines them into jump stitches of the maximum 12.7mm and reads the pattern with the combined jumps.
4 <u>Stitch sweeper</u>	No•Yes	: This function eliminates extremely short stitch for stitch width when reading pattern data.
5 Sweep length	0~8 (0~0.8mm)	: This setting controls the length of the stitches eliminated by the Stitch sweeper. Stitches shorter than this setting will be eliminated.
6 All pattern disp	No•Yes	: When pattern data is read from HAPPY's data disk (type TAP) with "DISK READING", pattern data other than HAPPY is also displayed. Usually, select "No".
7 Tajima name disp	Yes•No	: When patterns in Tajima format are read in, the display shows the file name.
8 <u>Data format</u>	0→Aut (Automatic) 1→HAPPY, Tajima 2→Barudan 3→Zsk	: Turn data format for reading patterns from data disk of HAPPY or Tajima with "DISK READING". Usually, set it to Automatic switch (0).
9 <u>etc.func read</u>	Yes•No	: This function reads various function setting which are set in pattern data together with pattern data (type TAP).
10 <u>Trace type</u>		: Lets you select the type of trace data that is created as a pattern is read in. → Maximum embroidery area of pattern → Out line

Detailed explanation of machine setting

4 Stitch sweeper

This removes stitches that are extremely narrow when reading pattern data and writing to machine memory. If thread breaks occur often at the same point in a pattern, this may be because of narrow stitches.

■ If the thread still breaks in the same place you can use this function again but repeated usage may distort the shape of the stitch.

1. Save the pattern to disk.
2. Conduct a stitch sweeping of the pattern and load it into the machine again.

End

7 Data format

This enables you to select a different format and read the pattern again if the machine did not read it correctly the first time.

9 etc.func read

*Various settings are saved together with a pattern. If some settings are changed in the pattern and you wish to return to the originals, simply reload.

■ The data may only be HAPPY format (TAP).

10 Trace type

You can compare the design size and design position to the embroidery frame before you start sewing.

The embroidery frame will move around the actual design size.

At this time you can choose which type of trace from the two types as seen in the following figure:

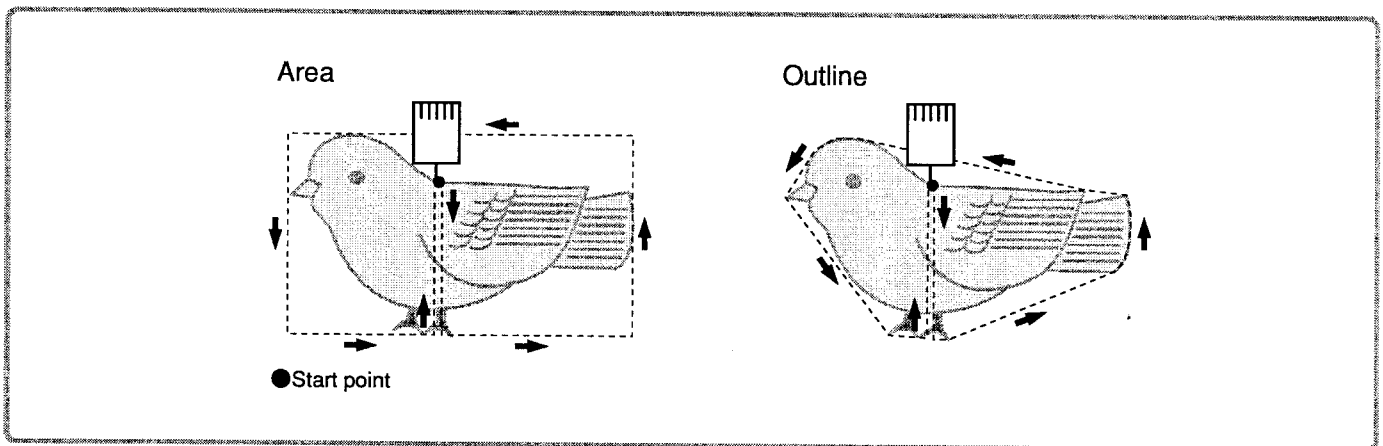

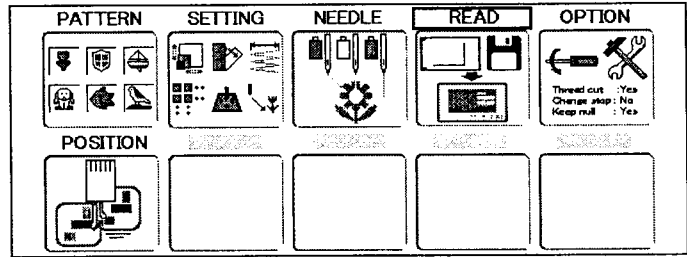

- When the machine is stopped, press **(MENU)** and Select "READ" with .

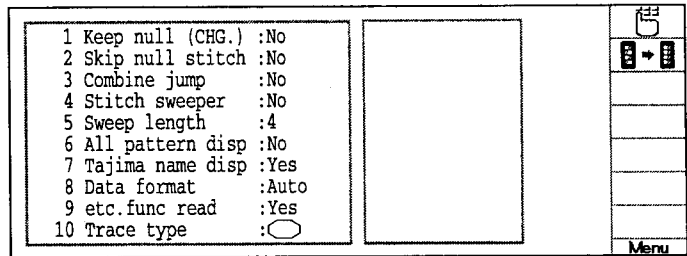

- Press the **(SET)**.
The setting status will be shown to the left.



- Press **(MENU)** and select  with .

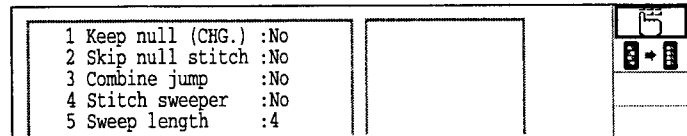

- Press the **(SET)**.
Ready to change settings.

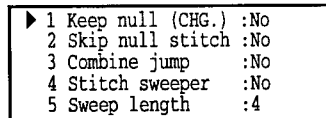

- Select desired setting item with  and press **(SET)**.

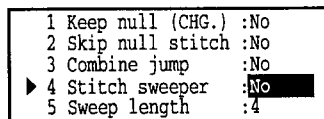

- Press up/down on  to change settings.

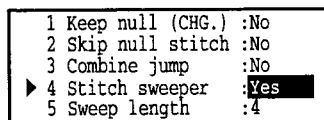

- Press the **(SET)**.
The setting is fixed.
If you change default settings they will be lit green.

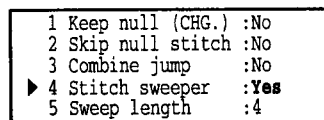

Other setting can be done by performing step 5 to 7.

Press **(ESC)** twice to return to Menu mode.
Press **(ESC)** once again to return to Drive mode.

● Restoring settings

This restores settings related to pattern reading.

1. When the machine is stopped, press **MENU** and Select "READ" with .

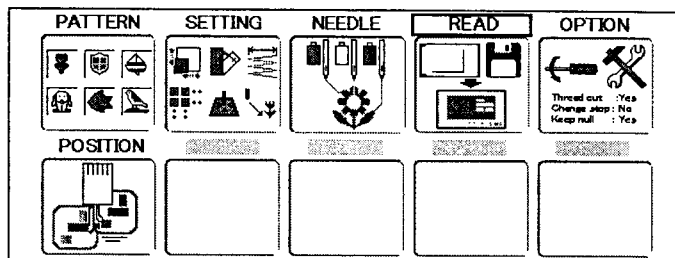

2. Press the **SET**.
The setting status will be shown to the left.

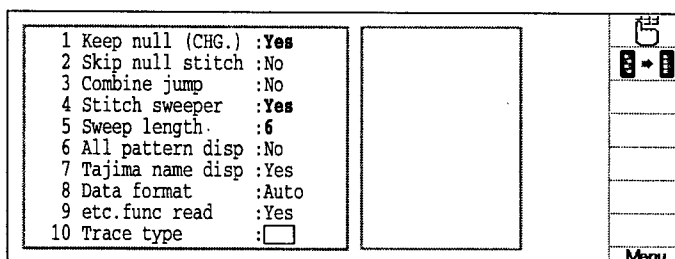

3. Press **MENU** and select   with .

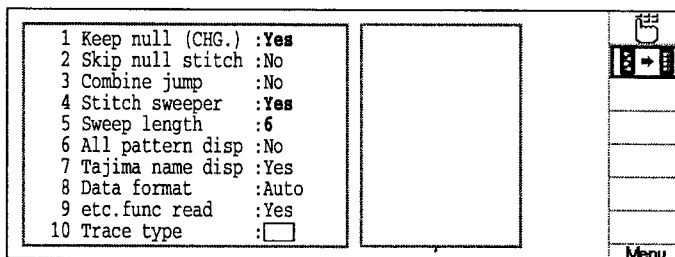

4. Press the **SET**.
All settings are returned to the default.
In case that the setting is restored, the color of status is changed to black.

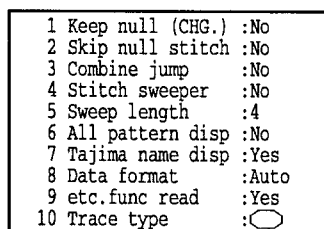

Press **ESC** twice to return to Menu mode.
Press **ESC** once again to return to Drive mode.

● Initialization of setting

Initialize all setting of basic function all at once.

1. When the machine is stopped, press **(MENU)** and Select "OPTION" with .

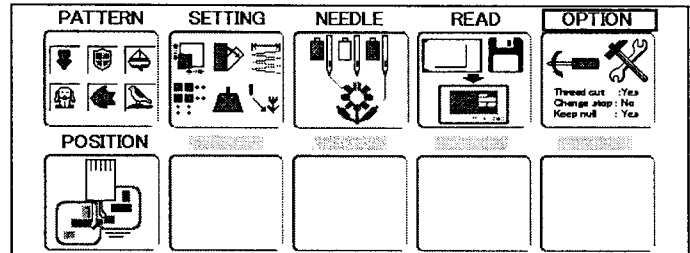

2. Press the **(SET)**.

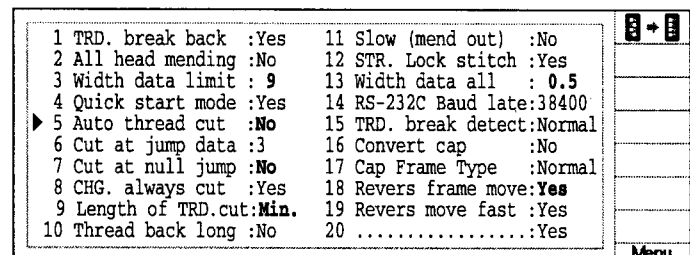

3. Press the **(MENU)**.

 in submenu is selected.

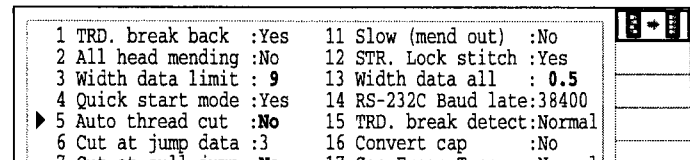

4. Press the **(SET)**.

All setting is returned to the default.
In case that the setting is initialized, the color of status is changed to black.

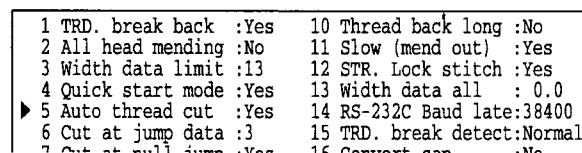

Press **(ESC)** to return to Menu mode.
Press **(ESC)** once again to return to Drive mode.

This creates direct designations to the number of stitches and *color change number, as well as setting the frame and data to the designated sewing position.

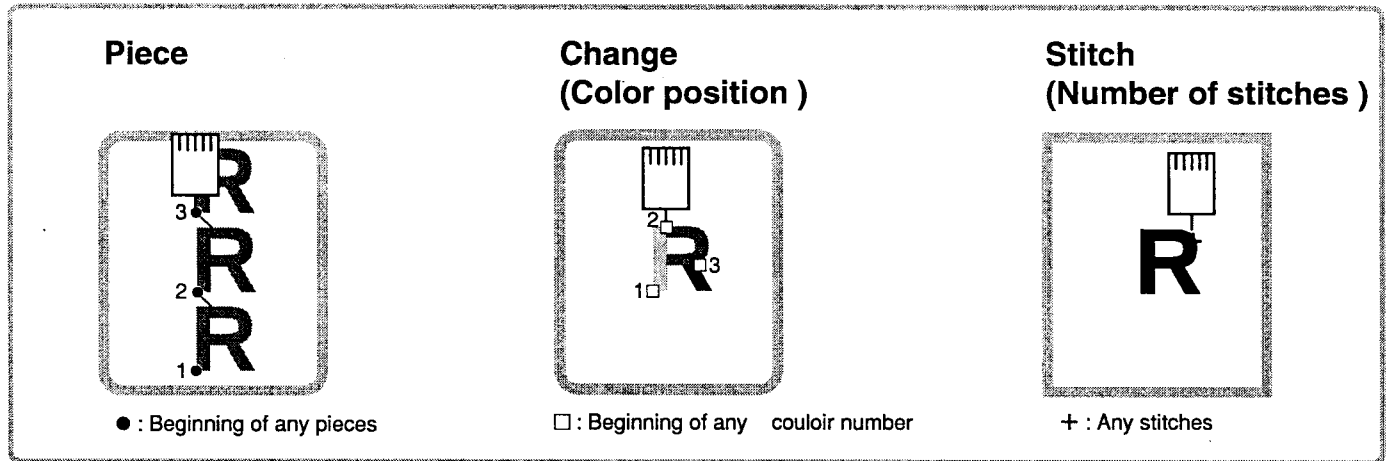

Piece

If "Repeat" is set, this allows the frame to move to the beginning of any piece at will.

- You can designate the order of pattern, the order of stitch and the order of piece by using "Number of Stitches", "Changing Position" and "Number of Piece".

Change (Color position) 9-7

This moves the frame to the beginning of any Color change number at will beginning of color.

Stitch (Number of stitches) 9-6

This moves the frame to any stitch at will.

Piece number

The frame and pointer can be moved a specified piece number.

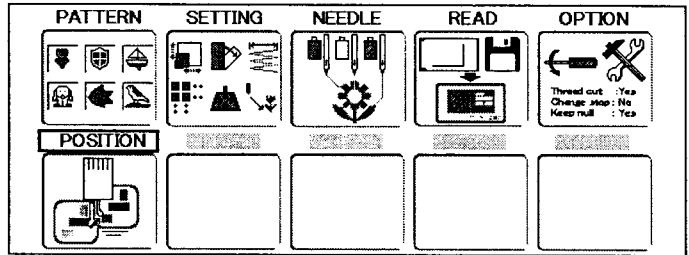

1. When the machine is stopped, press **MENU** and Select "POSITION" with .



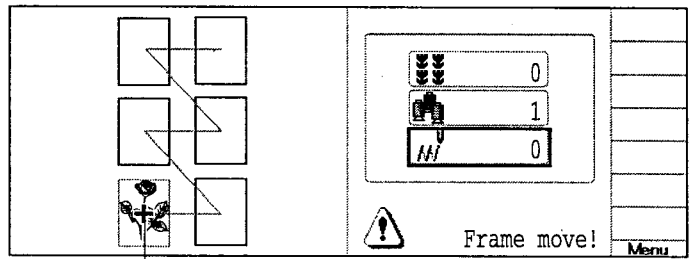

2. Press the **SET** button.



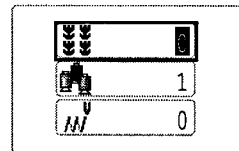

Pointer shows you the current position of the frame.

3. Press up/down of  to select  and press **SET**.

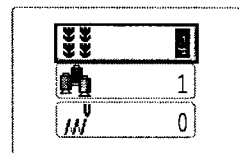

4. Press up/down of  to select the number and press right /left of  to select the digit.



 **CAUTION: To prevent accidents.**
The frame moves quickly.
Keep your hands away from the frame.

5. Press the **SET**.
The frame and pointer will move to the specified piece number.

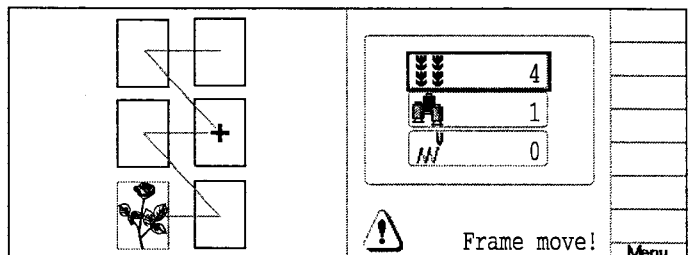

Selecting letters using the built-in fonts.

Save lettering embroidery data to design memory automatically.

1. When the machine is stopped, press **(MENU)** and Select "LETTER" with .

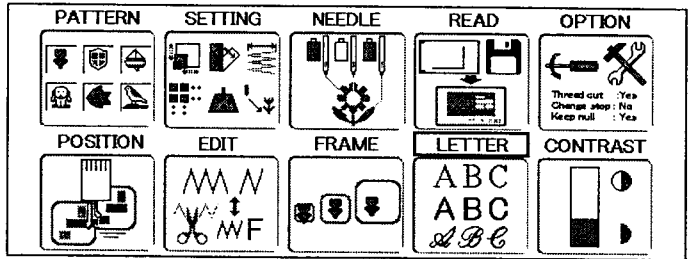

2. Press the **(SET)**.

Letter selection

To select letters. (15 letters maximum)

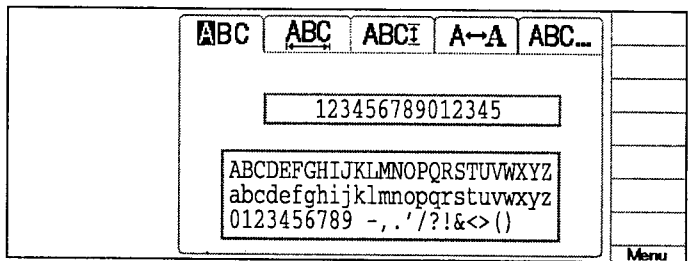

3. Press the **(SET)**.
The cursor will move to the left side of the entry frame.

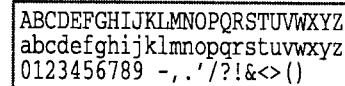

4. Select the position of the letter with .

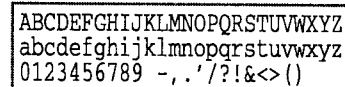
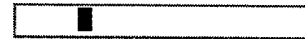

5. Press the **(SET)**.
Showing cursor on letter (character) pallet.

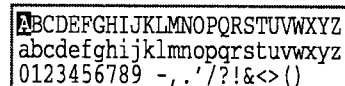

6. Select word with  and press **(SET)**.

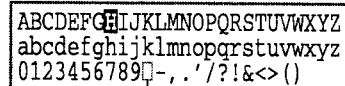
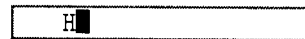

Space or Delete

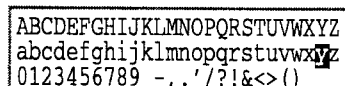

7. Repeat the procedure 6.. to select additional letters.
If you wish to insert a space it will not be recognized as a letter.

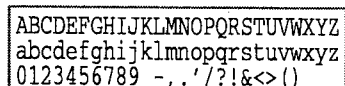



8. Press the **(ESC)** when you are finished with the letter selection.
Go out cursor on letter pallet.

9. Press the **(ESC)**.
Go out cursor then go to next step for "Line Length"

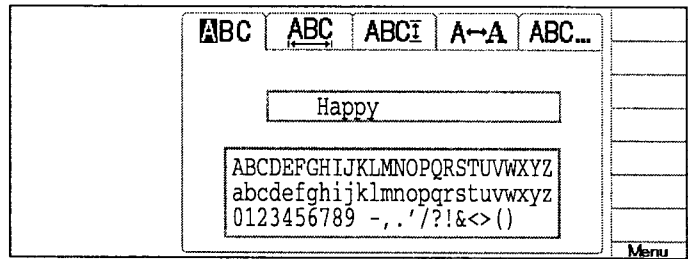

Line Length

Enables you to change the line length.
Area : 0 to 290 mm (the maximum hoop size)

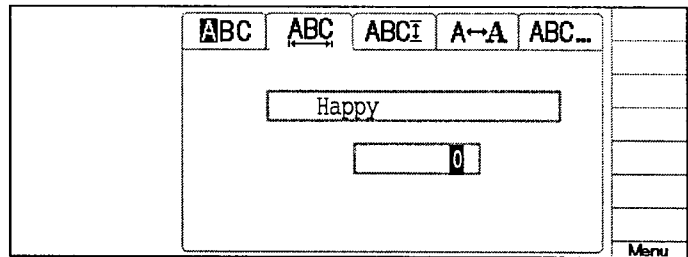

10. Press **(SET)** and press right of  to select **ABC**.



11. Press right /left of  to select the digit and press up/down of  to select the number.

When you select "0", set distance of each character 0.8 mm automatically.

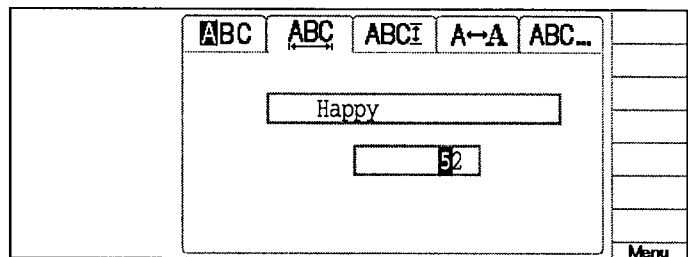



12. Press the **(ESC)**.
Fix your setting and go to next step for "Letter Height selection".

Letter Height selection

To select the letter size from Large , Middle or Small.

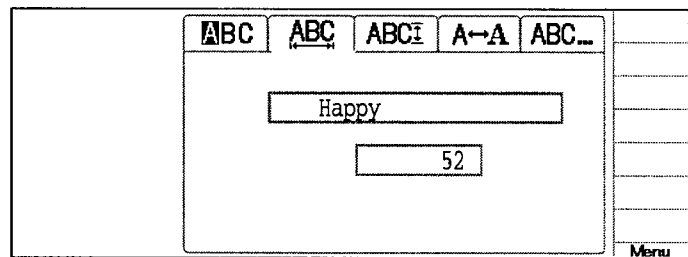
The letters can be set to one of 3 sizes.



13. Press **(SET)** and press right of  to select **ABCI**.

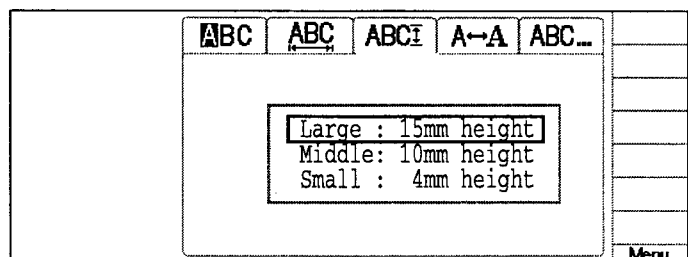

14. Select desired setting item with  and press **(SET)**.
Fix your setting and go to next step for "Font Selection".

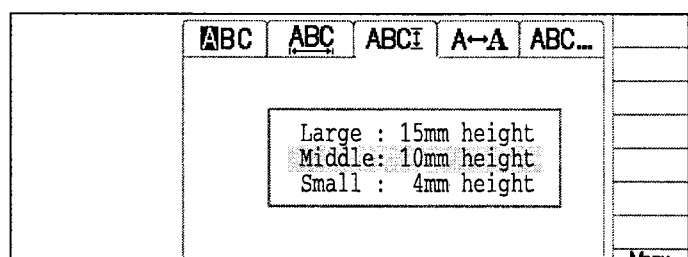



Font Selection

Enables you to select the preferred font.
 Selections are: Style 1, Style 2, or Style 3.

▣ 26-3

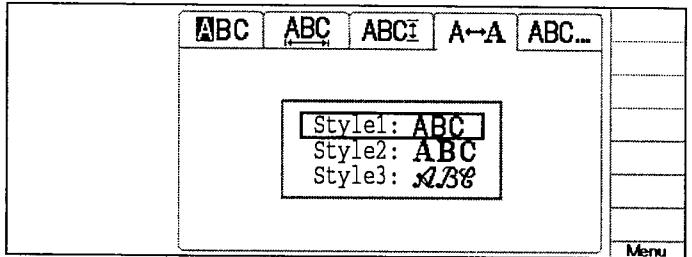
15. Press **SET** and press right of  to select **A↔A**.



16. Select desired setting item with  and press **SET**.

Fix your setting and go to next step for "Review and Create".

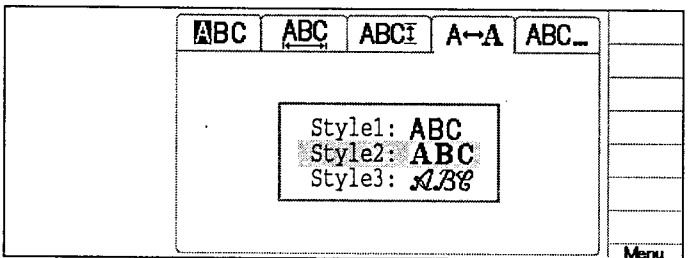

Review and Create

Enables the user to review the details of their letter selections, the line length selection, letter size selection, and font selection.
 Also, you can create embroidery data from the letter settings.

17. Press **SET** and press right of  to select **ABC....**

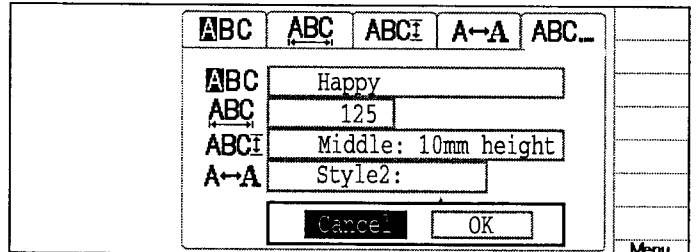

18. Press **SET** for determine of your setting.

then select "OK" by  and press **SET** for calculate embroidery data.

The new pattern data will be created. Then you will return to drive mode.
 The first 8 letters will be shown as the name of the pattern which you have made by letter selection.

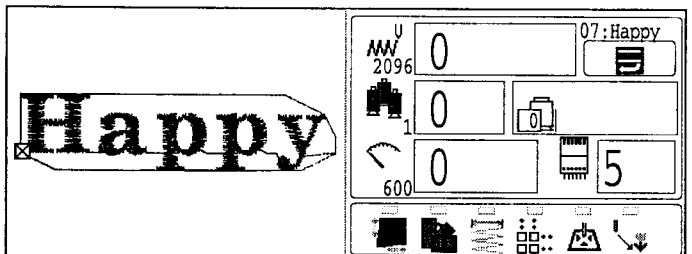
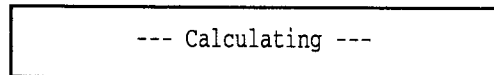

If you cancel, press **ESC**.
 You will return to Menu mode.

If you have "Area over!!" message on step #18.

Line length will be too long.

If resetting is needed

A. Select "Cancel" with  and press **SET**.

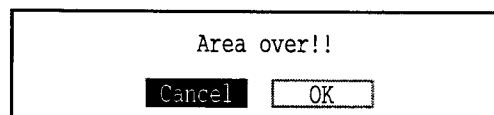

Reset the line length again as on page.

☐ 17-2 or.

Change the letter height selection as shown.

☐ 17-2

If it is acceptable to increase the size as shown

B. Select "OK" with  and press **SET**.

The new pattern data will be created. Then you will return to drive mode.

The first 8 letters will be shown as the name of the pattern which you have made by letter selection.

The distance between the letters will be set to 0.8 mm.

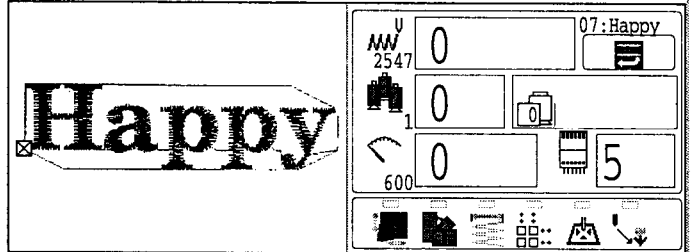

- All the selected settings will be deleted when the power source is turned off. Please be careful when making embroidery letters.

● Stitch selection

Select *stitch (number of stitches) for editing.

There are three ways to select stitches.

Color change number selection : Enter the stitch number you want to edit directly, then go to the particular stitch number.

Manual selection : Search for the stitch number you want to edit by moving back and forth by intervals of 1 to 1000 stitches.

Function selection : Search the only stitch including the function code such as jump, thread cut and etc.

S:1232 F: X: 0.8 Y: 6.4

S:1234 F: X: 0.8 Y: 6.4

S:1236 F: X: 0.8 Y: 6.4

S:1233 F: X: 0.8 Y: -6.4

S:1235 F: X: 0.8 Y: -6.4

S : Number of stitches
F : Function code
X : Sidewise move distance
Y : Lengthwise move distance

✦ shows selected stitch.

Color change number selection

- When the machine is stopped, press **(MENU)** and select "EDIT" with

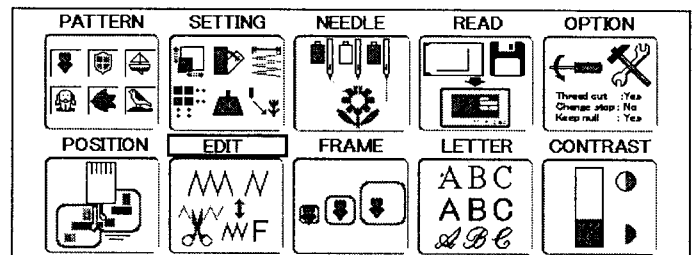

- Press the **(SET)**.
The right side shows the information of the current stitch.

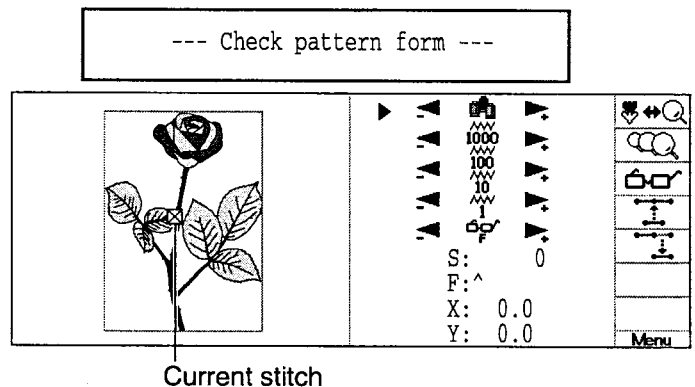

- Press right /left of to select desired color change number.

You can use "Function code", "Insert stitch" and etc. with this status.
Refer to the page for each editing procedure for more instructions.

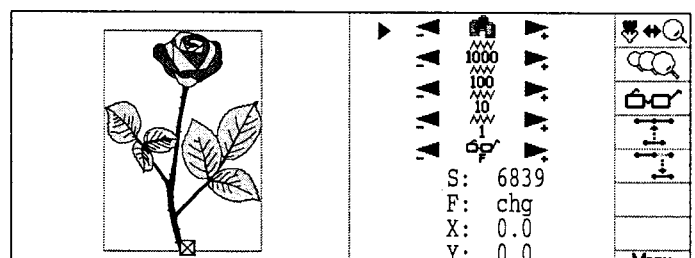

Manual selection

- When the machine is stopped, press **MENU** and Select "EDIT" with .

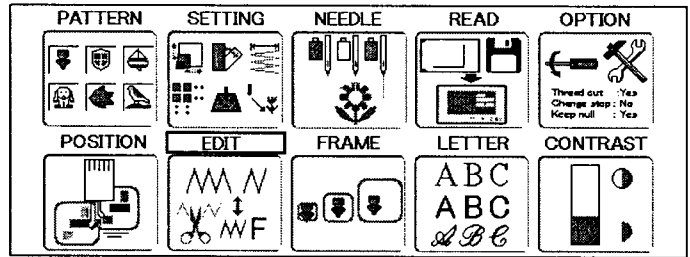

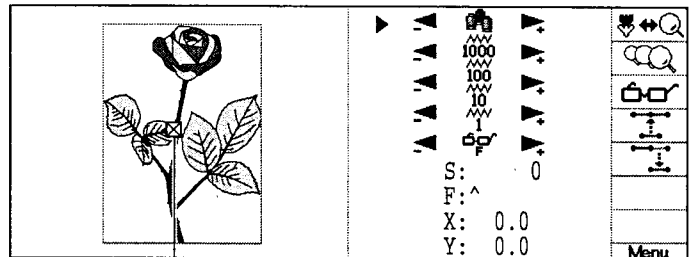

- Press the **SET**.
The information of selected stitch is showed at the right side of display.

--- Check pattern form ---



Current stitch

- Press up/down of  to select  1000 to  1 (interval of stitch).

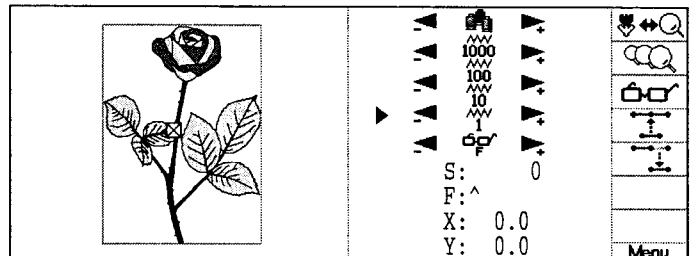

- Press right/left of  to move the stitch to forward or backward to select the desired stitch.

The stitch is searched with the selected interval of stitch.
You can edit "Function code", "Insert stitch" and etc. with this status.

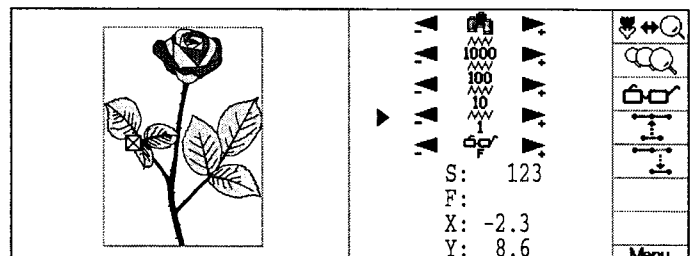

Function selection

1. When the machine is stopped, press **(MENU)** and Select "EDIT" with .

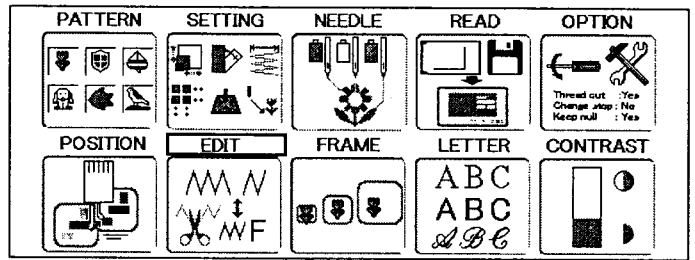

2. Press the **(SET)**.
The right side shows the information on the current stitch.

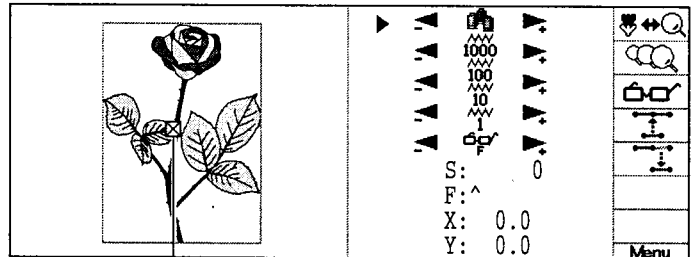

--- Check pattern form ---

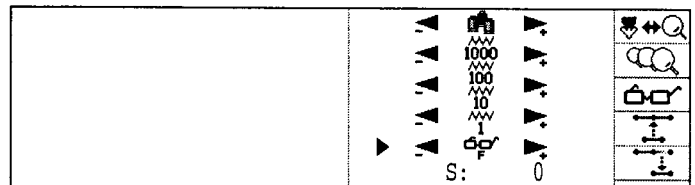

Selected stitch

3. Press up/down of  to select .



4. Press **(MENU)** and select  with .

The selected function is displayed.

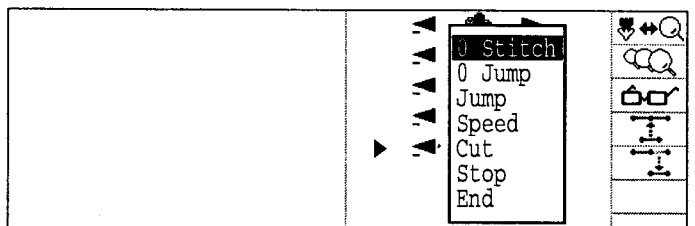

5. Press up/down of  to select the function.

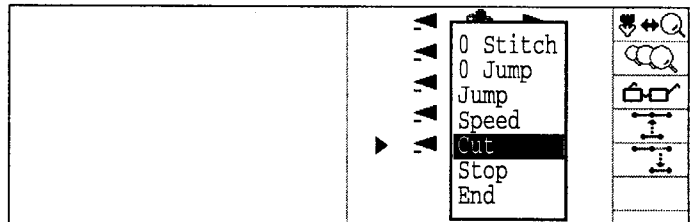

6. Press the **(SET)**.
The function is selected.

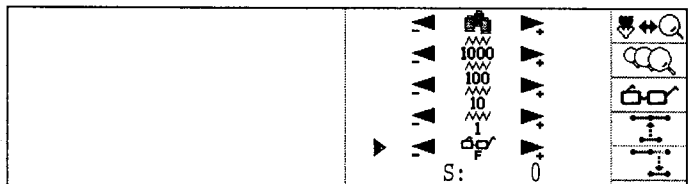

7. Press right/left of , to search the stitch.
You can use "Function code", "Insert stitch" and etc. with this status.
Refer to the page for each editing procedure for more instructions.

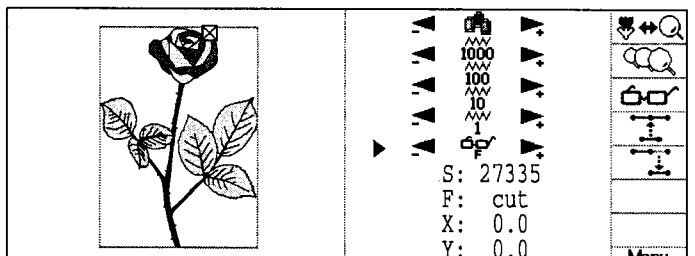



● Zoom in for the display

This enables zooming in the display.

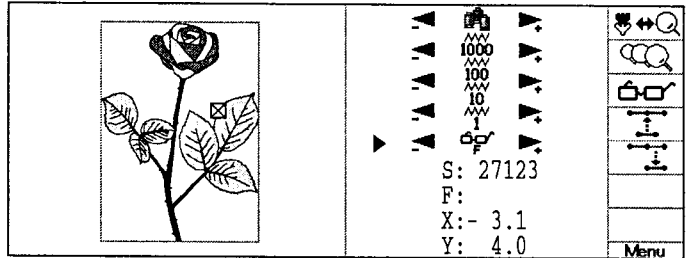
- Using "Stitch selection", the machine will display the intended stitch function code.



- Press **MENU** and select   with .

This indicates the display range while zooming in

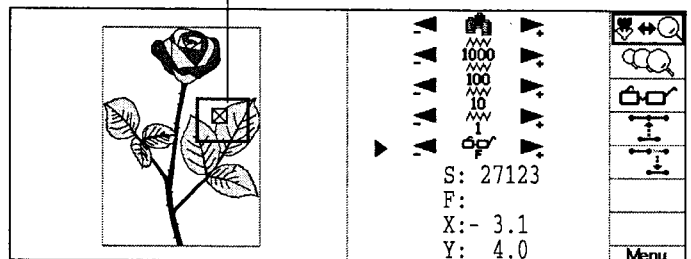

- Press the **SET**.

The pattern is zoomed in. In this mode, you can use "Color number selection", "Manual selection" and "Function selection".

The functions are displayed as function marks.

- Function mark
- : Stitch (Normal)
 - : Jump
 - ▲ : Color change
 - * : Speed limit
 - × : Thread cut
 - # : Stop
 - : Start point
 - : End point

The pointer indicates the stitch currently selected. 500 stitches before and after the pointer are displayed.

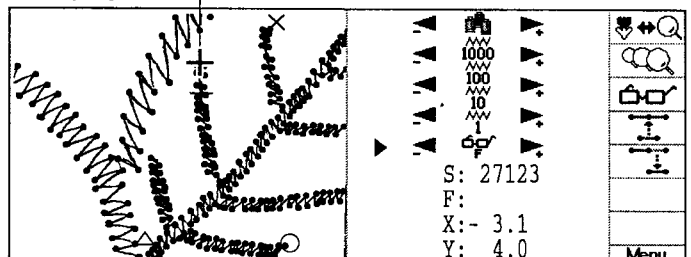

Zooming rate

The zooming rate can be adjusted.

1. Follow the steps for "Zoom in for the display" at the previous page to display the pattern zoomed in.

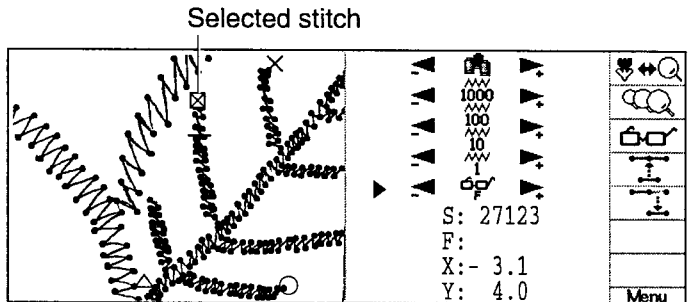

2. Press **(MENU)** and select  with .

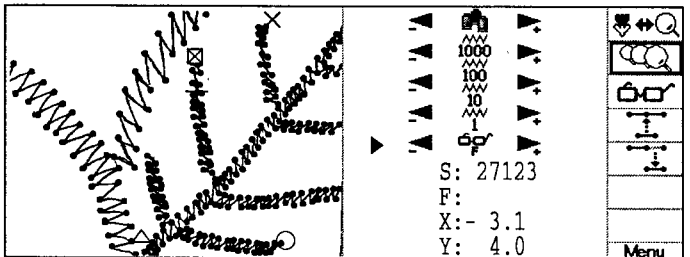

3. Press the **(SET)**.
The display shows the current zooming rate.

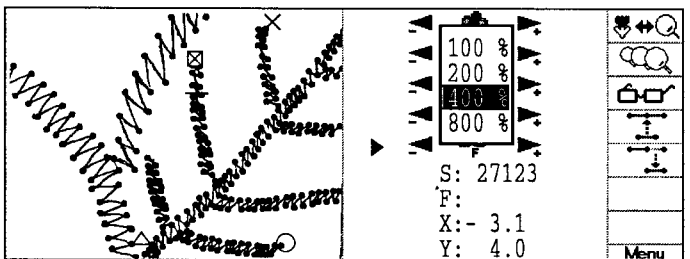

4. Press up/down of  to select zooming rate.

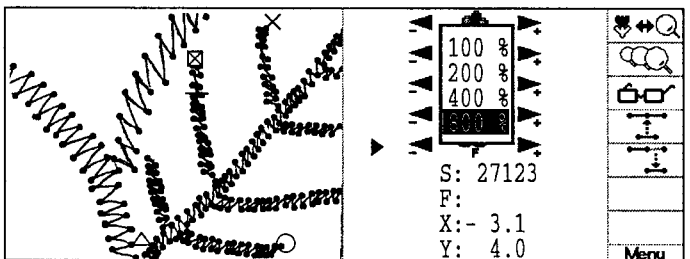

5. Press the **(SET)**.
The zooming rate of display is changed.
In this mode, you can use "Color number selection", Manual selection" and " Function selection".

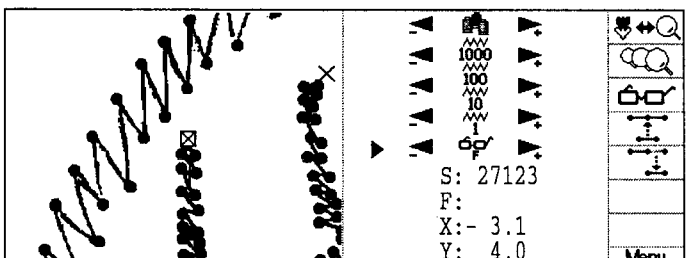

● Function code

This is function code is for additions, changes and erasures on desired stitches.

Before editing

Ex. 1 after editing
The jump and speed limit are added.

Ex. 2 after editing
The color change is added.

S : Number of stitches
F : Function code
X : Move data of sidewise
Y : Move data of lengthwise

⊕ shows selected stitch.

FUNCTION CODE	ACTION OF THE MACHINE
-	Normal
sph	Speed limit H
sp1	Speed limit 1
sp2	Speed limit 2
sph	Speed limit M
cut	Thread cut
stp	Stop
chg	Color change
^	Jump

Speed limit	rpm			
	Model	Low	Middle (Cap)	High (Cap)
HCS	300	800 (600)	1000 (750)	
HCD	300	700 (650)	900 (800)	

* Figures in bracket means cap frame use.

- When you add a color change function (chg), a zero stitch with a color change function (chg) is added after selected stitch. Refer to the figure above. (Ex. 2 after editing)
- Except for color change functions (chg), you can join jump functions (^) with all other function codes. When you enter a jump function (^) in a color change set stitch, the display will appear but you can't execute this setting.
- Stitch editing is not available during stitch no.0 to 1023.
- You can't add a color change (chg) and end (end) at the end of the pattern.
- In the middle of embroidery, when you move the frame with *trace back or *thread brake back etc. where a speed limit is used, and then resume embroidery, the speed limit will not be used for that portion of the embroidery.
If you must use a speed limit for this portion of the embroidery, set a new speed limit behind the stitch where you resumed embroider or reduce speed with the speed adjustment knob.
- When "Stop (stp)" is set, the machine displays following message and stops.

>> Change Stop

- If a thread cut is used in the middle of a pattern as below, there is lack of seams because the needle comes down to the next stitch from the stitch where the thread cut was used as illustrated in Ex. 3. If you must have a seam, add a *zero stitch behind the thread cut as illustrated in Ex. 4. This causes the needle to come down on the thread cut stitch with zero stitches and there will be no seams. For instructions on zero stitches, refer to the page "Insert stitch, Erase stitch" in "DATA EDIT".

Before editing

Ex. 3 after editing
The thread cut function is added.

Ex. 4 after editing
The thread cut function is added.

S : Number of stitches
F : Function code
X : Move data of sidewise
Y : Move data of lengthwise

- Using "stitch selection" from the preceding page the machine will display either of the intended stitch function codes.

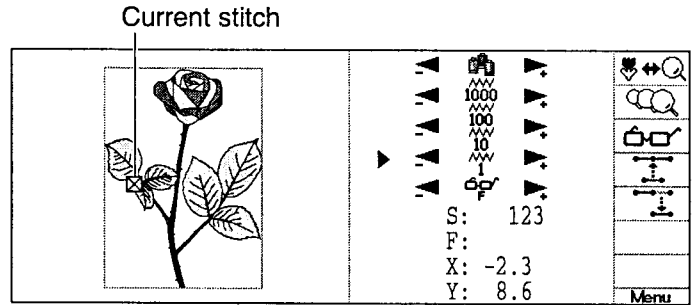

- Press the **SET**.

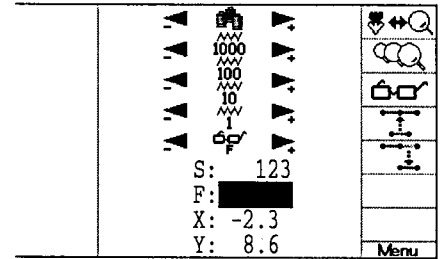

- Press up/down of to select desired

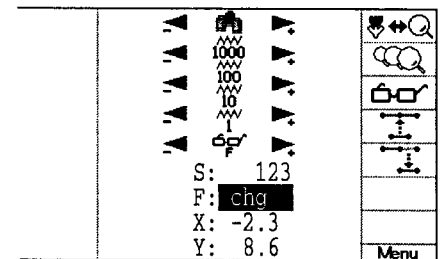

Keypad Number	Function code	description
0	No function	Normal
1	sph	Speed control normal
2	sp1	speed control 1
3	sp2	speed control 2
4	sp3	speed control 3
5	cut	thread trim
6	stp	stop command
8	chg	color change
+/-	.^	jump

- If you add a color change the machine inserts a empty stitch after the command.
- You can combine a Jump command with any other command except a color change. If you combine a color change and a jump command it will show in the menu but.
- You can not edit or insert a command on the last stitch of a design.

- Press the **SET**.
The function is set.

Set O.K.

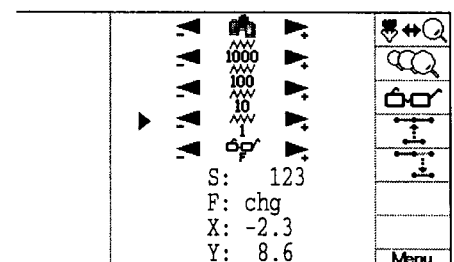

When you finish the editing, go to "Finish editing". 19-A

● Insert stitch ● Erase stitch

Add *zero stitch to selected *stitch or erase the selected stitch.

■ The stitch with move data can not be erased.
You will receive an error if you attempt it.

Before editing

S:1232	S:1234	S:1236
X: 0.8	X: 0.8	X: 0.8
Y: 6.4	Y: 6.4	Y: 6.4

S:1233	S:1235
X: 0.8	X: 0.8
Y: -6.4	Y: -6.4

S: Number of stitches
X: Move data of sidewise
Y: Move data of lengthwise

⊕ shows selected stitch.

Insert
Insert zero stitch at stitch No.1233.

S:1232	S:1235	S:1237
X: 0.8	X: 0.8	X: 0.8
Y: 6.4	Y: 6.4	Y: 6.4

S:1233	S:1236
X: 0.8	X: 0.8
Y: -6.4	Y: -6.4

S:1234
X: 0.0
Y: 0.0

S: Number of stitches
X: Move data of sidewise
Y: Move data of lengthwise

⊕ shows selected stitch.

Before editing

S:1232	S:1235	S:1237
X: 0.8	X: 0.8	X: 0.8
Y: 6.4	Y: 6.4	Y: 6.4

S:1233	S:1236
X: 0.8	X: 0.8
Y: -6.4	Y: -6.4

S:1234
X: 0.0
Y: 0.0

S: Number of stitches
X: Move data of sidewise
Y: Move data of lengthwise

⊕ shows selected stitch.

Erase
Erase stitch No. 1234.

S:1232	S:1234	S:1236
X: 0.8	X: 0.8	X: 0.8
Y: 6.4	Y: 6.4	Y: 6.4

S:1233	S:1235
X: 0.8	X: 0.8
Y: -6.4	Y: -6.4

S: Number of stitches
X: Move data of sidewise
Y: Move data of lengthwise

⊕ shows selected stitch.

Insert stitch

1. Using "stitch selection" from the preceding page, the machine will display either of the intended stitch function codes.

Current stitch

2. Press **(MENU)** and select with .

3. Press the **(SET)**.

A zero stitch is inserted at the selected stitch position.
If needed, add function code according to "Function Code". **P** 19-6



Insert

When you finish the editing, go to "Finish editing". **P** 19-A

Erase stitch

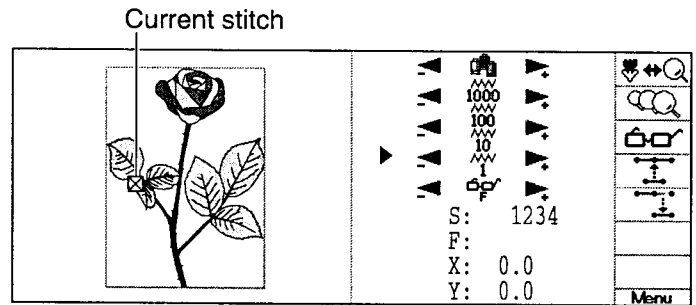
- Using "stitch selection" from the preceding page the machine will display either of the intended stitch function codes.



- Press **(MENU)** and select  with .

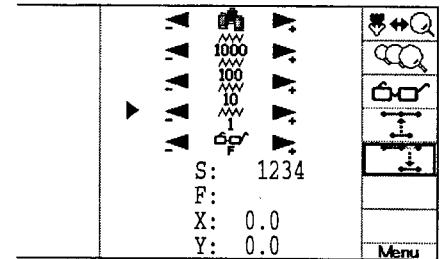

- Press the **(SET)**.
The selected stitch is deleted.
The stitch number deleted is replaced with that of the next stitch.

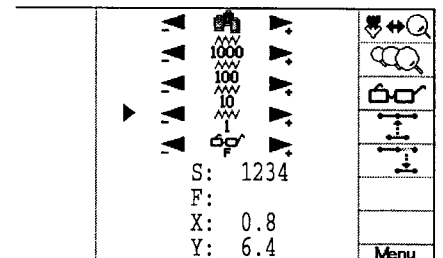
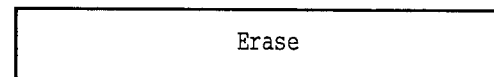



When you finish the editing, go to "Finish editing".  19-A

●Finish editing

When you finish editing, follow these steps.

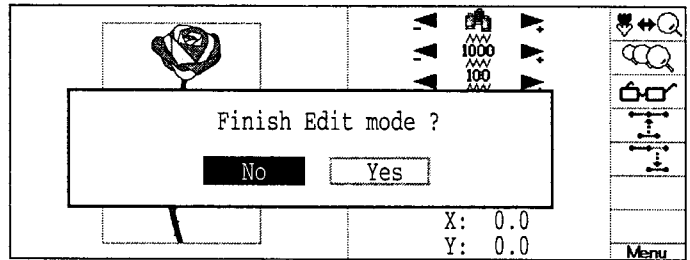
1. Press the **(ESC)**.



2. When you finish, select "Yes" with  and press **(SET)**.

The edit is finished and the display returns to MENU.

If you wish to cancel, press **(SET)**.

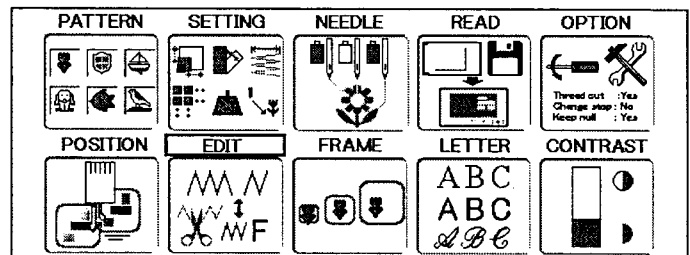

If you Press the **(ESC)** you will return to Drive Mode.

By default the machine adjusts the position of the pattern to the center of the frame and checks if the pattern fits the embroidery area.

This helps you to check whether or not the selected pattern fits in the desired hoop.

The pattern can be centered to each frame (round, square, cap). This helps confirm positioning between the embroidery area and the pattern.

If you change the frame position by the frame move key, the display will be changed and you can check the position onscreen.

- ⚠ The "monitor display" checks whether or not the pattern fits the embroidery area of the frame you are going to use before starting the operation.
This is not a safety device that will prevent crashes if pattern size is too large for the frame; it is intended for your reference only when judging the fit of a pattern to a given size frame. After using "monitor display", do not move the frame. If you do so the machine may be damaged due to the needle or pressure foot hitting the frame.
- ⚠ Make sure to perform "Registration number selection" when changing hoop size. If not done, the machine may be damaged from the needle or pressure foot hitting the frame.

- This function can be used with the function of scale, *convert, mirror, width adjustment, offset, frame out and repeat sewing setting.
- This function can not be used with the function of batch drive setting.

● Tubular round frame, Tubular square frame

Selecting a frame (Tubular Round frame, Tubular Square frame).

The embroidery area for each registered frame is set to the inside of the frame edge to allow for pressure foot clearance. (Fig. 1)

This allows confirmation of positioning between the embroidery area and the pattern.

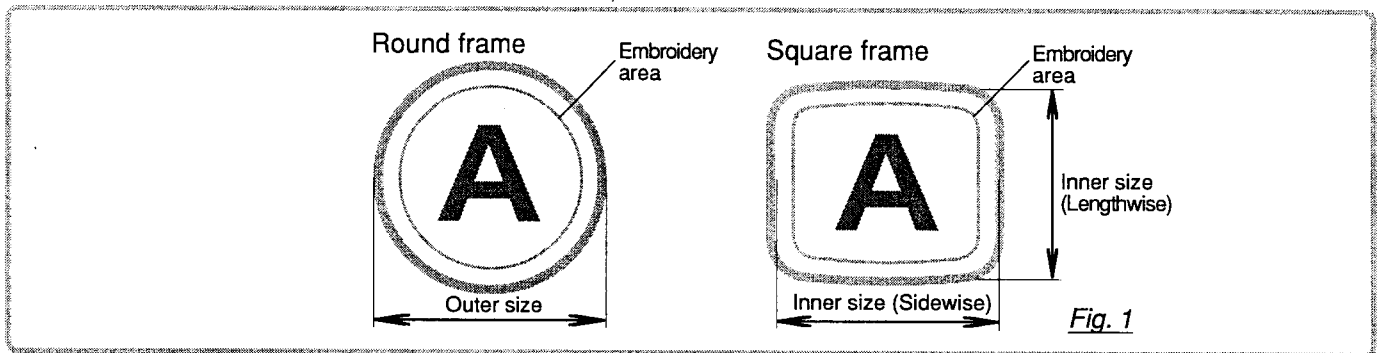

1. Confirm that  (Top) appears in the display and go to step 4.
If this does not appear, go to step 2.

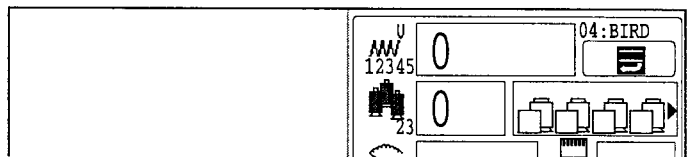

2. Press **(FUNC)** and select "Top" with .

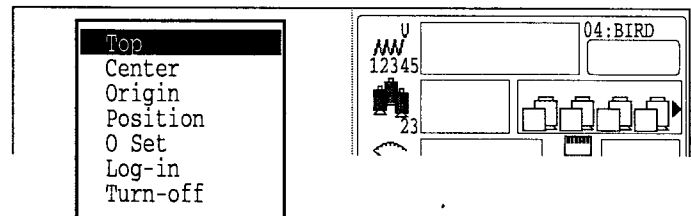

3. Press the **(SET)** button.
Upper right indication of  will be shown.

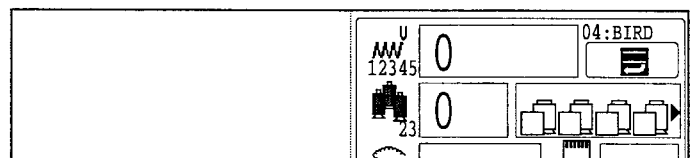

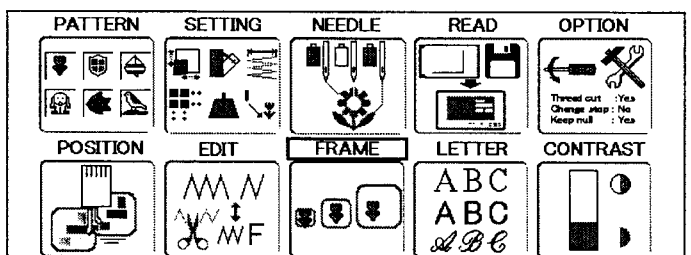

4. Press **(MENU)** and Select "FRAME" with .

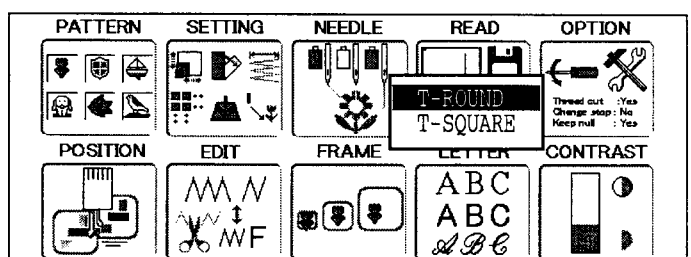

5. Press the **(SET)** button.
Indicates the select frame.

T-ROUND : *Tubular Round frame
T-SQUARE : *Tubular Square frame



6. Select the type of frame with .



7. Press the **SET** button.

The type and shape of the frame (black) and embroidery area (red) is displayed to the left.

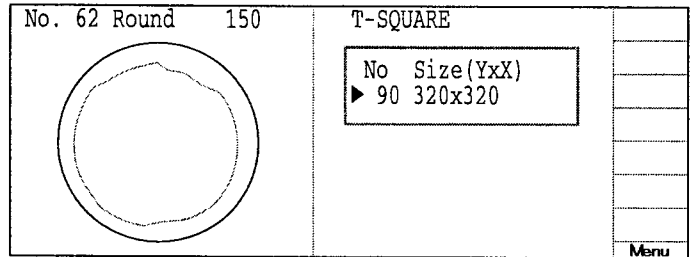

CAUTION: To prevent accidents.
The frame moves quickly.
Keep your hands away from the frame.

8. Press up/down of  to select desired frame and press **SET**.

The frame moves, so that the pattern can fit to the center of the frames.
The type and shape of the frame is in black and embroidery area and outline of the pattern itself appear in red. All are displayed on the left together.
This helps you to check the fit of the pattern in the embroidery area.

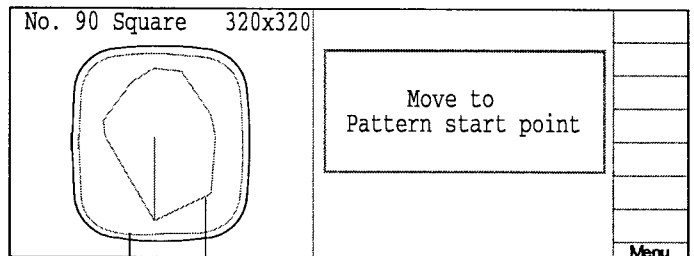

Embroidery area Outline of pattern

9. If the pattern can not fit the embroidery area or the position needs to be moved, change the position of pattern with .

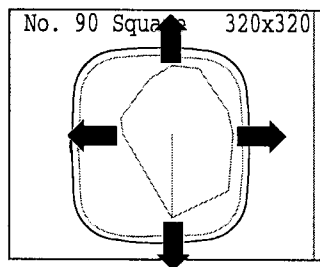

10. Press the **ESC**.

Setting is fixed and the display returns to MENU.

To start embroidery immediately, press **ESC** to return drive mode and press **START**.

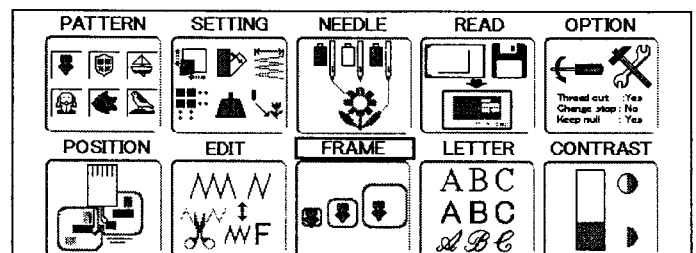

Press **ESC** to return to Drive mode.

●Cap frame

The embroidery area of HAPPY semi-wide and wide cap frames is saved in the machine. The Y axis of the embroidery area can be adjusted for a variety of caps. (Fig. 1)

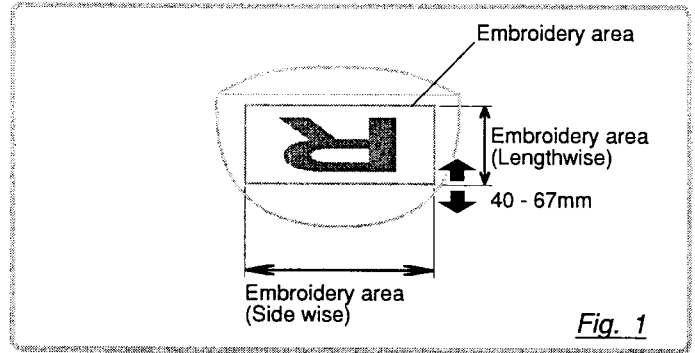

1. Confirm that  appears in the display and go on to step 4.
Go to step 2, if this symbol does not appear.

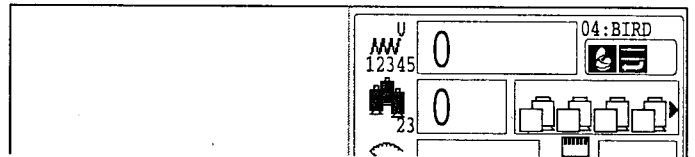

2. Press **(FUNC)** and select "Top" with .

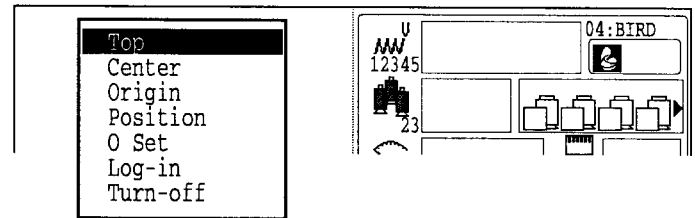

3. Press the **(SET)** button.
 will be shown.

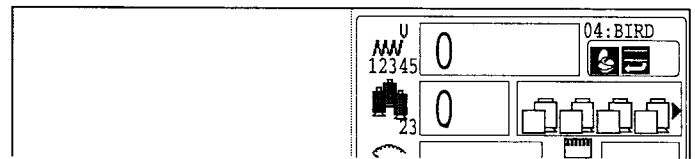

4. Press **(MENU)** and Select "FRAME" with .

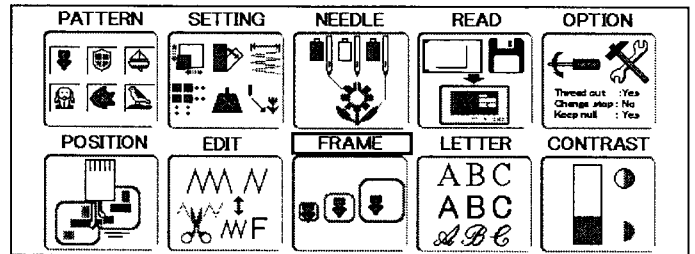

5. Press the **(SET)**.
Indicates the select frame.
CAP : Cap frame

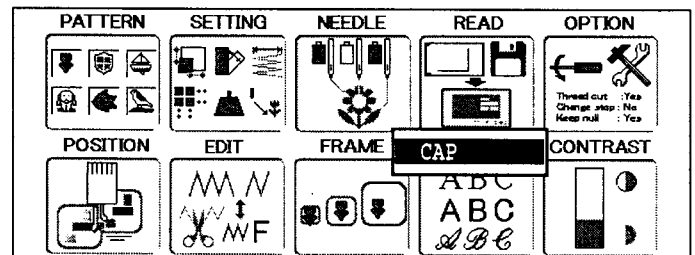

6. Select "CAP" with .



FRAME CONFIRMATION

The frame size and embroidery area (red) are displayed to the left.

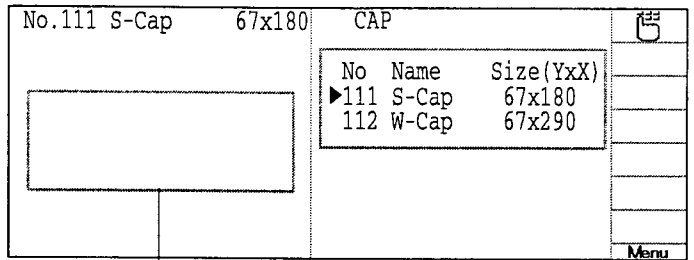

Embroidery area

8. Press up/down of to select desired frame.

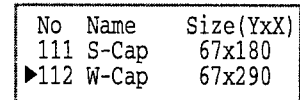

9. Press **(MENU)** and press **(SET)** for change embroidery area.

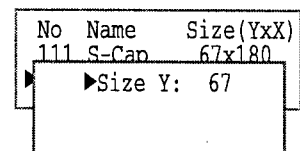

If you do not need to change, go to step 14.

10. Press the **(SET)** button.

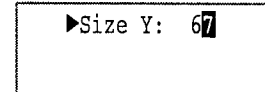

11. Press right /left of to select the digit and press up/down of to select the number.

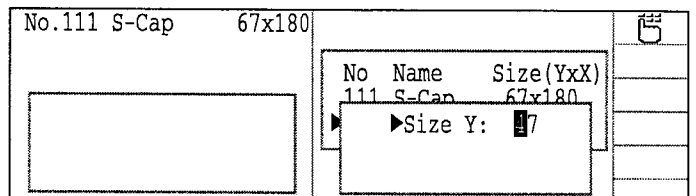

Enter the width of the cap.

Size Y : 40 ~ 67mm

12. Press the **(SET)** button.
The setting is fixed.

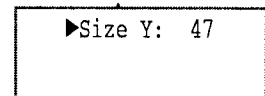

13. Press the **(ESC)**.

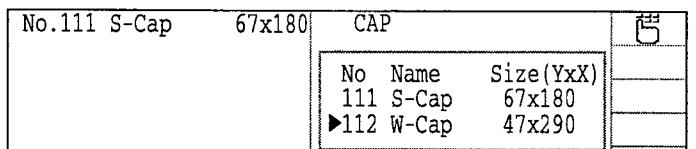

CAUTION: To prevent accidents.
The frame moves quickly.
Keep your hands away from the frame.

14. Press the **(SET)** button.

The head moves left to needle 1.
The frame moves so that the pattern can fit in the center of the frame.
The type and shape of the frame (black) and embroidery area (red) and outline of pattern (red) are shown to the left.
This helps you check if the pattern fits the embroidery area of the frame or not.

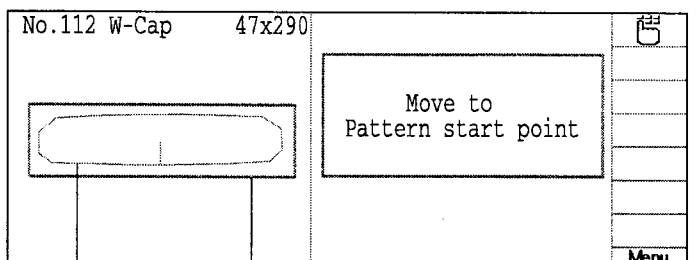

Outline of pattern Embroidery area

FRAME CONFIRMATION

15. If the pattern can not fit the embroidery area or the position needs to be moved change the position of the pattern with .

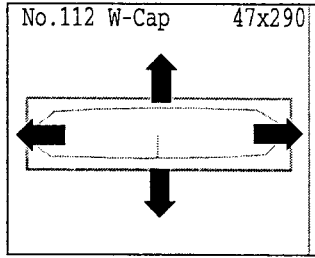

16. Press the **ESC**.

Setting is fixed and the display returns to MENU.

To start embroidery immediately, press **ESC** to return drive mode and press **START**.

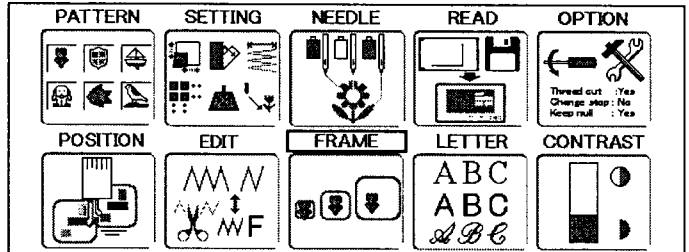

Press **ESC** to return to Drive mode.

● Create network

Set this menu when you use Network cable to connect PC and machine(s).
Also use separate network software instruction together with this setup.

1. When the machine is stopped, press **MENU** and Select "OTHER" with .

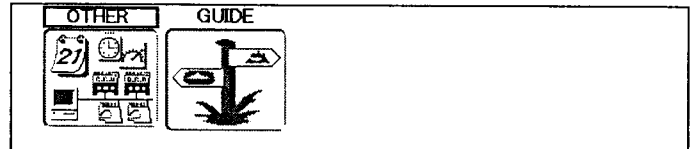

2. Press the **SET** button.

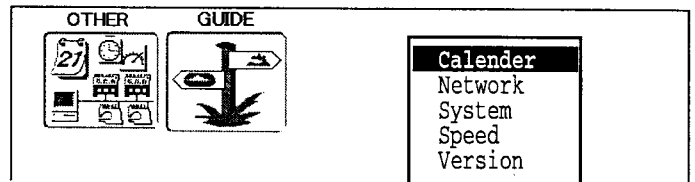

3. Select "Network" with  and press **SET**.

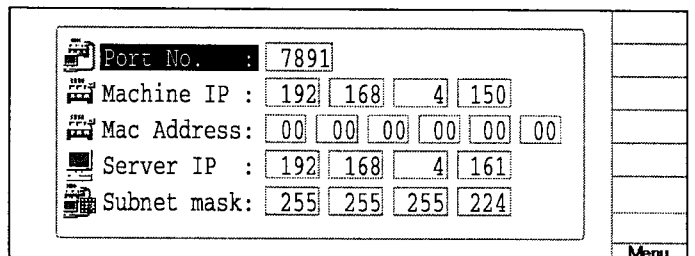

4. Press up/down of  to select the desired item.

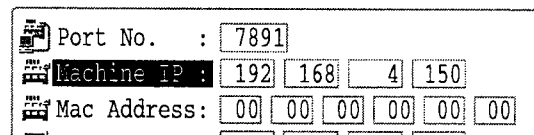

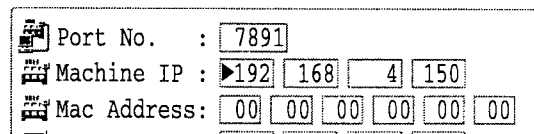

5. Press the **SET** button.

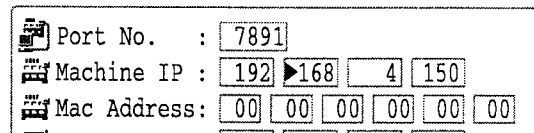

6. Press right /left of  to select the desired setting to change.



7. Press right /left of  to set the value and press up/down of  to select the number.

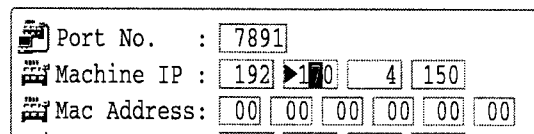

8. Press the **SET** button.

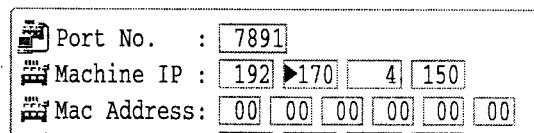

9. Press the **ESC** button.

The setting is fixed.
Other settings can be done by repeating steps 4 through 9.

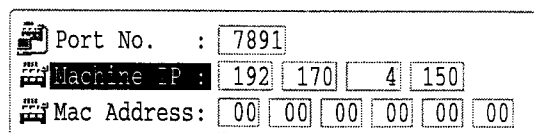

OTHER SETTINGS

10. Press the **(ESC)** button.

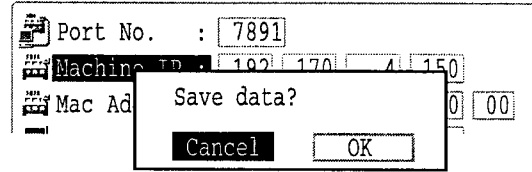

11. To save your settings, please select "OK"

with  and press **(SET)**.

The setting is fixed and the display returns to MENU.

To cancel your setting, please select "Cancel"

with  and press **(SET)**.

The setting is canceled and the display returns to MENU.

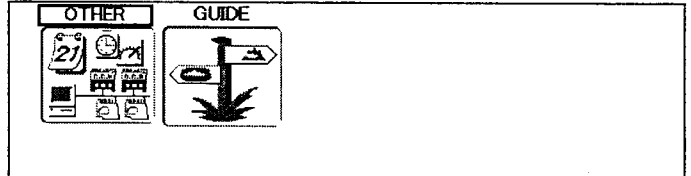

Press **(ESC)** to return to Drive mode.

● Version information

Displaying machine operation software version number.

1. When the machine is stopped, press **(MENU)** and Select "OTHER" with .

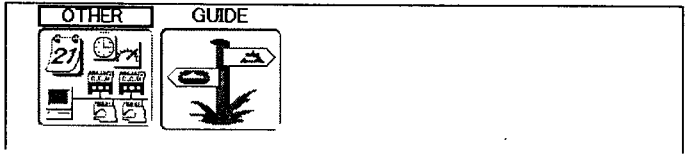

2. Press the **(SET)** button.

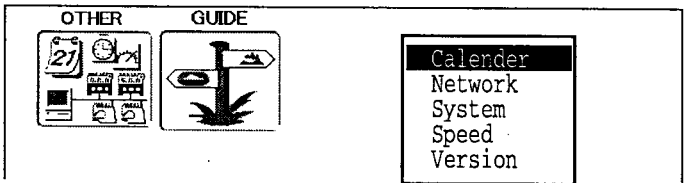

3. Select "Version" with  and press **(SET)**.

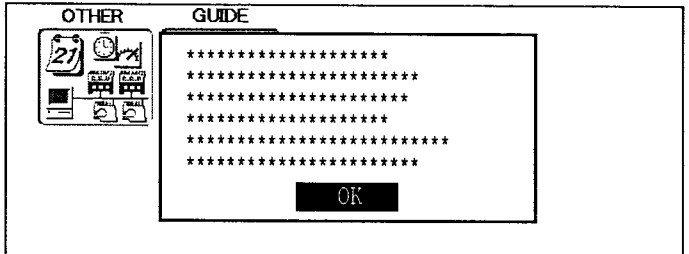

4. Press **(SET)** after confirm version number.
The display returns to MENU.

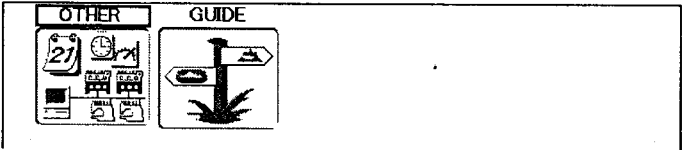

If you press the **(ESC)** you will return to drive mode.

● Specifications

Voltage	1 phase 100V ~ 115V -10% ~ +5%	1 phase 200V ~ 230V -10% ~ +10%
Electricity consumption	220 Wh	220 Wh
Frequency	50 / 60Hz	
Environmental condition	Temperature 0 ~ 40° C Moisture 45 ~ 85 %	
Dimension (Width x Height x Depth)	687 mm x 734 mm x 745 mm, 27.1" x 29" x 29.3"	
Weight	42 Kg	
Embroidery area (Y x X)	Tubular frame (Sew field of PTA-32320) 285 mm x 290 mm, 11.2" x 11.4" Max.*1 Normal cap frame (Option) 67 mm x 180 mm, 2.6" x 7" Max.*2 Wide cap frame (Option) 67 mm x 290 mm, 2.6" x 11.4" Max.*2	
Memory capacity	250,000 stitches	
Registered pattern	99 pat.	

*1 Actual embroidery area will be restricted in accordance with inner frame size.

*2 Actual embroidery area will be restricted in accordance with shape of a cap.

■ Specifications are subject to change without notice.

● Oiling



CAUTION: To prevent accidents.

When performing maintenance, be sure to disconnect the power cord.

The machine will periodically prompt periodically for lubrication based on the number of stitches sewn.

When powered on, the machine will display an icon and letter to indicate that lubrication is necessary. 3-4

- | | |
|--|--------------|
| | Place to oil |
| | Place to oil |

Please lubricate the specified oil locations according to the instructions below.

Running the machine without proper oiling will damage the machine. Lint will gather in and around the rotary hook. Rotary hooks then wear which will cause the threads to break. Please clean lint with a brush and run the machine idly for 2 ~ 3 minutes.

Mark	No.	Place to oil	Specified oil
A	1	Rotary hook (Lubricate with oil slightly with a small brush and sewing machine oil between the outer and inner rotary hook parts.)	Sewing machine oil
B	2	Pressure foot guide bar	
	3	Head shaft	
	4	Needle bar	

■ When oiling the pressure foot guide bar, please move the head to the left and set it to needle No. 1.

■ Too much oil may stain fabrics and threads.

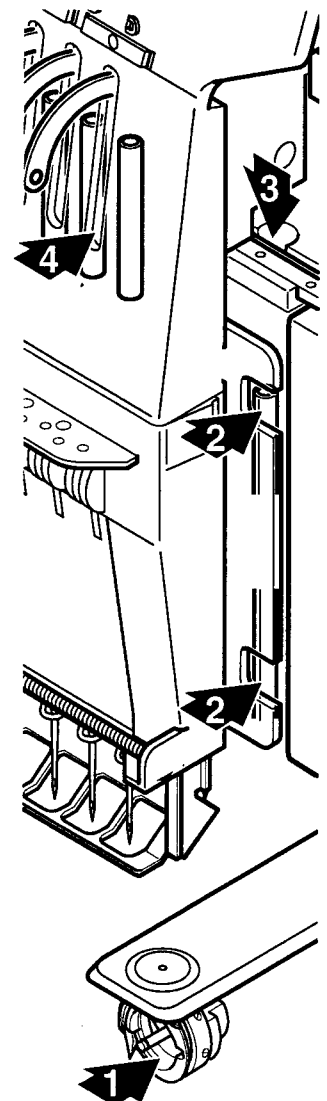

⚠ CAUTION: To prevent accidents.
When taking care of the machine, be sure to remove the plug.

● Cleaning of the rotary hook

If the rotary hook is clogged with waste thread or dust, it will degrade the stitch quality of the embroidery or may cause other problems. For a long sewing life, please keep the rotary hook clean.

Use the included brush for cleaning the hook.

● Cleaning the thread cutting knife

If the thread cutting knife is clogged with waste thread or dust, the knife will not work correctly. Please keep the thread cutting knife and device clean.

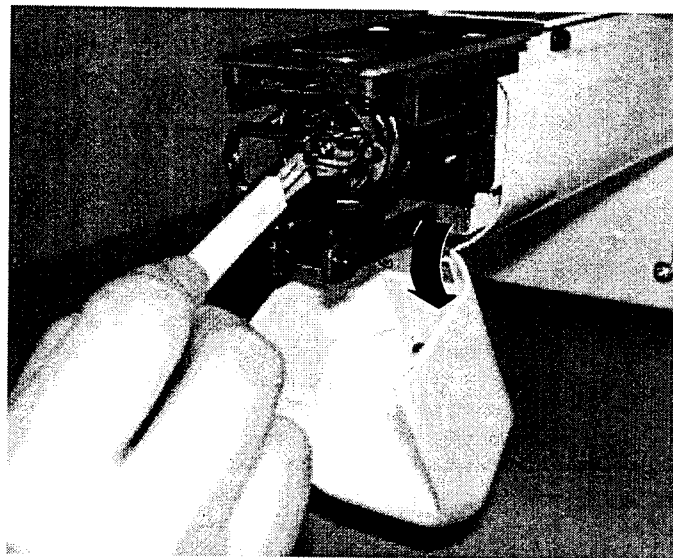

1. Remove set screw (2 pieces) by offset driver and remove the needle plate.
2. Turn the main shaft toward the arrow mark until the gauge points to the "C" point by using the 3 mm hexagonal driver.
3. Insert manual lever and pull down the manual lever that is in the left hand side of the machine as you face it.
4. Keep pressing the manual lever and turn the main shaft toward the arrow mark until it points to the "L" point.
5. Remove any waste thread and dust from the thread cutting knife and surrounding area.
6. Adjust the main shaft until the gauge points to the "C" point.
Thread cutting knife returns to the original position.
7. Remove manual lever and put the needle plate back on the bed and attach it with the screws (2 pieces).

Please do not keep manual lever to knob.
Please take care of manual lever.

⚠ CAUTION: To avoid problems.
Never press the manual lever while the machine is running.

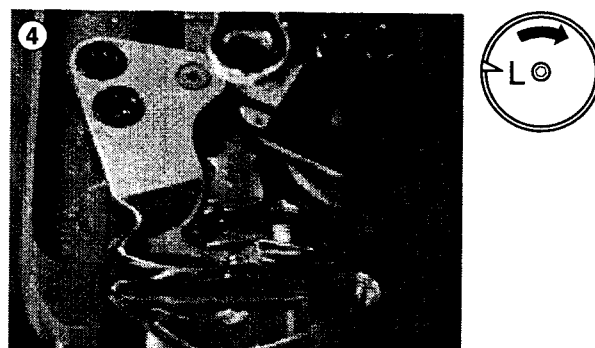
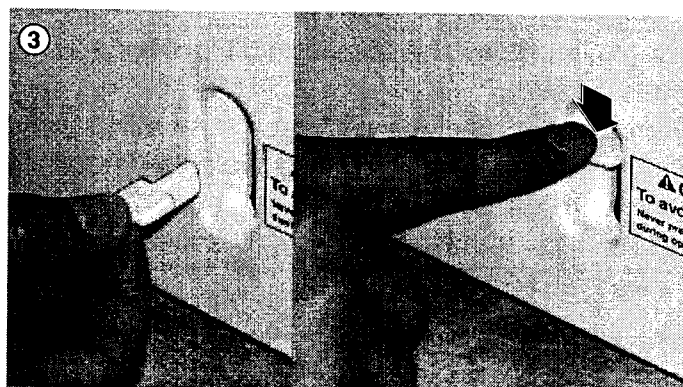
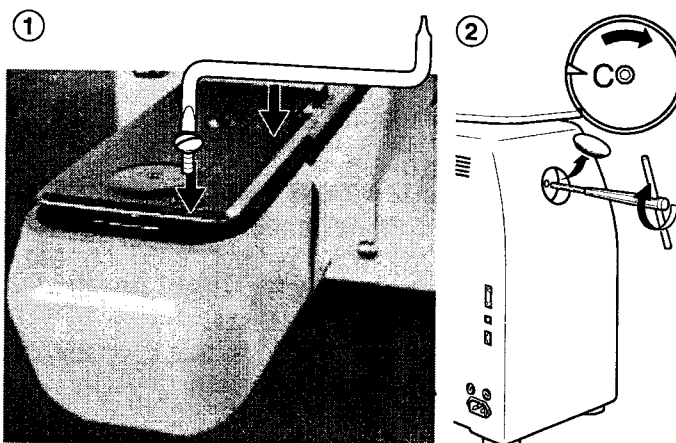

ERRORS AND WHAT TO DO

24-1

The machine has an extensive error code list to aid in troubleshooting when problems occur, as listed below. Upon error,

press the **SET** button on the controller to release the error and correct it according to the list below.

When errors occur frequently, please contact your dealer.

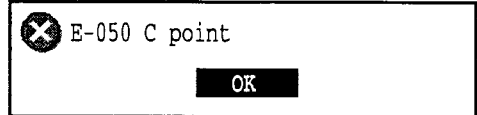

Automatic errors backup

The machine recovers from some errors (E-050, E-190, E-193) automatically after detecting the error(s) by it self. In cases where the machine does not recover from the error automatically, follow the "Solutions" below according to the indicated error number.

CAUTION: To prevent accidents.
In case of "Automatic errors backup", the machine's sudden movement might be caused without showing errors or messages after its stoppage.

No.	Display	Error	Solutions	Page
001	Circuit board	Abnormality detected in control circuit board	Power down machine and, after 10 seconds, power on again.	
004	System memory	System memory fault		
015	Inverter trip	Sewing motor-related trouble. Overload, short circuit, trouble with motor drive unit	Cut power and turn main shaft by hand. If turns normally, power on again. Fig. 2	
018	Main shaft	Main shaft will not turn.	Turn main shaft manually at least 1 full turn & ensure that it turns freely, clearing any jam. Then, re-initialize machine system and speed.	11-1 11-2
020	Needle detect	Machine not detecting current needle # correctly, or needle bar selection unit is off its stop position. Trouble with position-detecting circuit board.	Turn needle bar selector to the fixed position (marked area shown in Fig.1).	
021 022	Needle move	Motor for needle bar selection unit has stopped partway through its path. No movement due to malfunction of thread take-up lever or trouble of position-detecting circuit board	After fixing malfunction of needle and thread take-up lever, turn needle bar selector shaft with wrench to have it set at center of fixed position (range within which needle bar selector doesn't move) Fig. 1	
024	Needle center	Needle bar stop position is off-center; needle bar stop position is out of place.	Turn needle bar selector with 3mm hex wrench to have it set at center of fixed position (scope within which needle bar selector doesn't move).	
025	Needle over	Needle # out of range of actual needles on given machine.	Fig. 1	
026	Needle differ	Needle # differs between		
030	Slow mismatch	Improper speed adjustment at low speed. Speed does not decrease below 100rpm at low speed.	Re-initialize machine system and speed.	11-1 11-2
050	C point	Main shaft is stopped in a position other than "C" point	See Fig. 2 below.	10-6

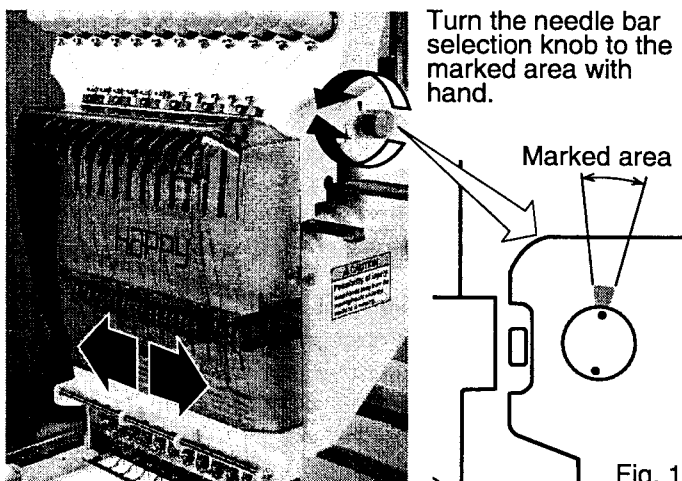

Fig. 1

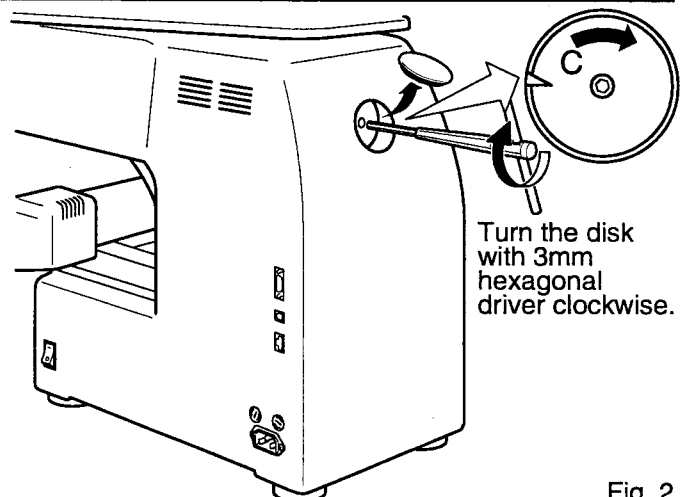

Fig. 2

ERRORS AND WHAT TO DO

24-2

No.	Display	Error	Solutions	Page
051	L sensor	Timing detection board fault, or marred photo-sensor. Malfunction of "Lowest needle position" sensor [PH2] on detection circuit board. Improper adjustment of slit plate.	Check to see if photo sensor is clean or if the slit plate contacts sensor. Re-initialize machine system and speed.	11-1 11-2
052	C sensor	Timing board detection fault, or marred photo-sensor. Malfunction of "Color change position" sensor [PH1] on timing detection circuit board. Improper adjustment of slit plate.		
055	Take-up cover	Take up lever cover is open.	Close the take up lever cover.	
060	X limit	Frame/pantograph has moved beyond sewing area along X-axis.	Return frame within sewing area using the frame movement keys on the control boxl.	
061	Y limit	Frame/pantograph has moved beyond sewing area along Y-axis.	Check pattern size and center mark to ensure that it is within size range of selected hoop and also properly centered.	
090	Miss reception	Error has occurred during data transfer (via cable) between machine and PC.	Try reading pattern data again. Verify that transmission speed setting is correct at (1) transfer software; (2) device manager of PC and (3) RS-232C speed of machine.	5-4
091	No send	Machine has not received data for > 10 seconds during data transfer.		
103	Data format	Machine unable to determine format of pattern data.	Verify format of pattern data and fix if necessary.	5-2
104	Miss function	Timing to read pattern data does not conform.	Read pattern data again from the start.	5-4
105	Dual function	Data has been detected in the pattern that has ambiguous/dual function.	Read pattern data again from the start.	5-4
108	Improper read	While reading pattern data, error has occurred in internal processing.	Read pattern data again from the start.	5-4
110	Memory full	Memory has filled while reading in a design.	Delete unnecessary patterns from machine memory and try again.	10-1
111	Change over	While reading pattern data, # of color changes (color No.) has exceeded 250.	Divide pattern data such that number of color changes of each segment is less than 250.	
112	Data error	Pattern data of current design is damaged.	Delete pattern and re-load.	5-8
114	Id over	# of patterns in control panel memory has exceeded the maximum of 99.	Delete unnecessary patterns from machine memory and try again.	5-8
118	Trace data over	Over 1024 stitches trace data were created during reading of pattern data.	Set maximum stitch length to embroidery area of pattern data within 2m (lengthwise) x 2m (sideways).	5-2
120	Memory error	Fault in retaining contents of pattern memory.	If this occurs frequently, it is likely that CPU is faulty. Contact your Dealer.	
130	Card error	Unable to communicate continuously with memory card or data disk.	Power down machine and after a 10 seconds, power on again. If error remains, contact your Dealer.	
131	Card no ready	Memory card or data disk is not set.	Check if memory card or data disk is properly set.	5-5
133	Bad card	Improper or faulty data disk or data disk.	Data disk that disk drive unit can't read or faulty memory card or un-initialized card. Data disk that disk drive unit can't read or faulty data disk or un-initialized disk.	5-5
141	Not found name	Designated pattern is not found.	Memory card is not correct.	5-5

ERRORS AND WHAT TO DO

24-3

No.	Display	Error	Solutions	Page
190	Cut blade	Thread cut knife is not at stop position.	Follow the instructions below.	10-7
193	Catcher	Thread catch hook is off its position. Limit switch to detect position is not "OFF".	Please follow the example below: 1. Check whether thread was actually cut by thread cutting knife. If not, cut thread and return catch hook to its normal position. 2. If thread is actually cut, check if thread catch hook on head has returned to its position completely.	10-8

What to do when Stop position of main shaft is out of place (error E-050)

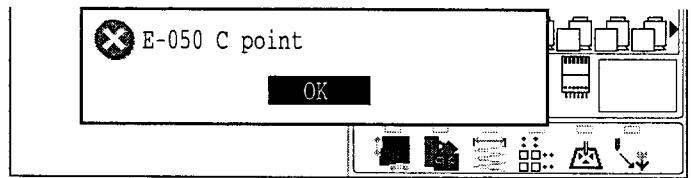

1. Press the **SET** button.

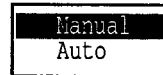

2. Select "Auto" with .



3. Press the **SET** button.

The main shaft turns 2 to 3 times and returns to a stop position ("C" point) automatically. The display returns to drive mode.

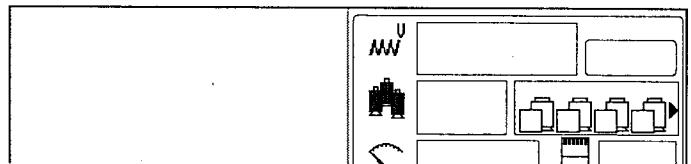
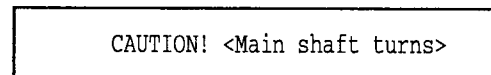

When you cannot clear by the method above (Auto)

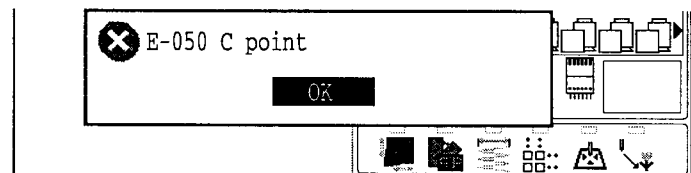

1. Press the **SET** button.



2. Press the **SET** button.

The error status is released and the display shows "drive mode".

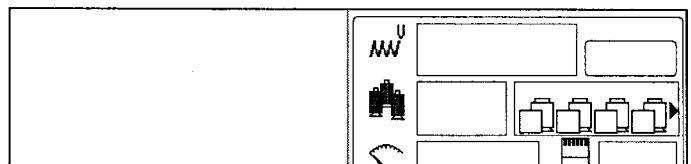

3. Remove the cap over the small hole in the rear of the machine. Using a 3 mm hexagonal wrench, Please turn the main shaft and adjust it to the "C" point.

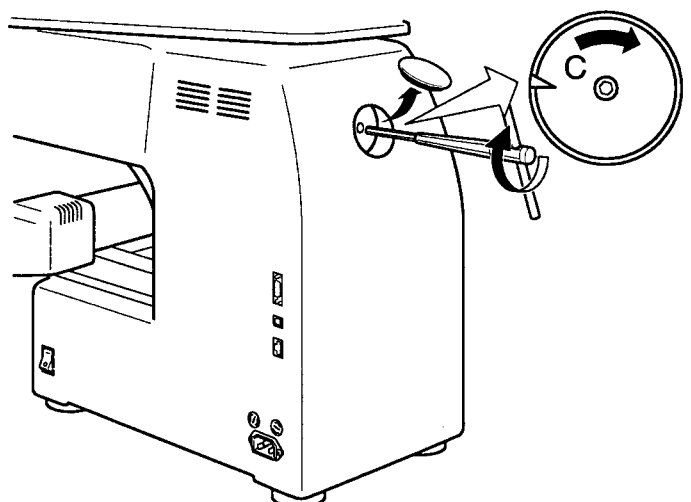

What to do for "Thread cut knife is not at the stop position (error E-190)"

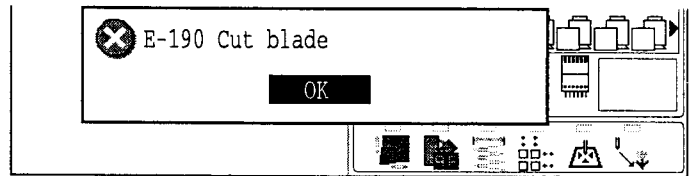

1. Press the **SET** button.



2. Select "Auto" with .



3. Press the **SET** button.

The display returns to the drive mode.

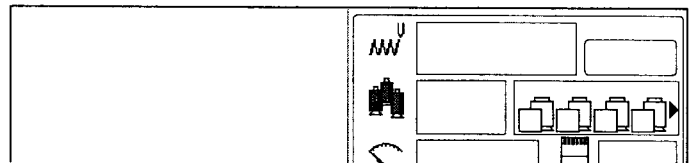

When you cannot clear by the method above (Auto)

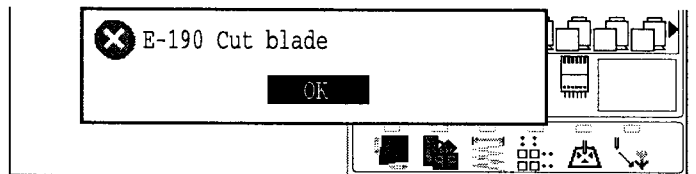

1. Press the **SET** button.



2. Press the **SET** button.

The error status is released and the display shows "drive mode".

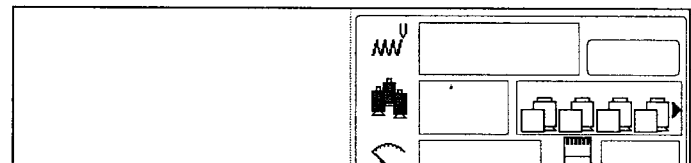

3. Using the 3 mm hexagonal wrench, Please turn the main shaft and adjust it to the "C" point.

4. Insert manual lever that is in the left hand side of the machine as you face it.

5. While pressing the manual lever, turn the main shaft a complete revolution and set it to the "C" point.

The knife will return to it's proper position.

6. Remove the manual lever.

Please do not keep manual lever to knob.
Please take care of manual lever.

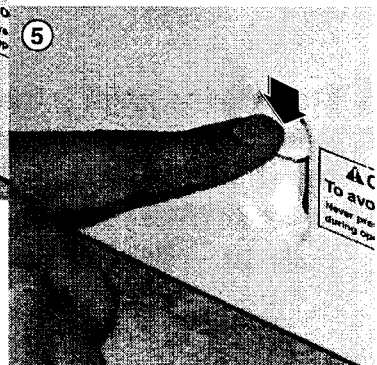
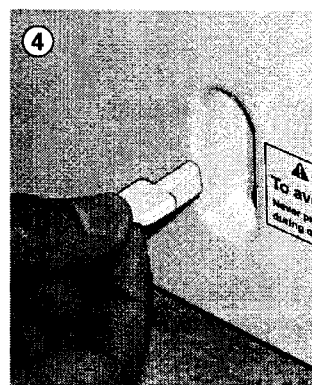
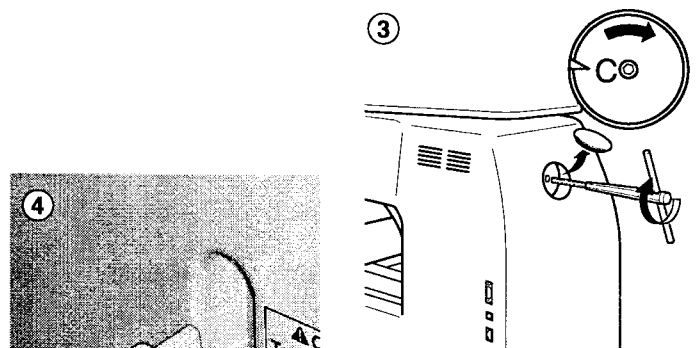

CAUTION: To avoid problems.
Never press the manual lever while the machine is running.

What to do for "Thread catch hook is off its position (error E-193)"

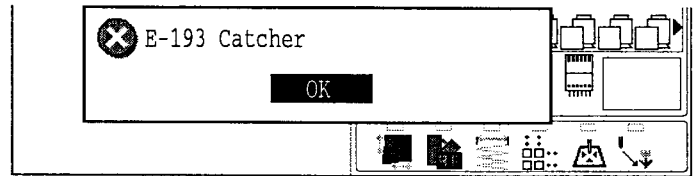

1. Press the **SET** button.



2. Select "Auto" with .



3. Press the **SET** button.

The thread catch hook returns to the original position.
The display returns to drive mode.

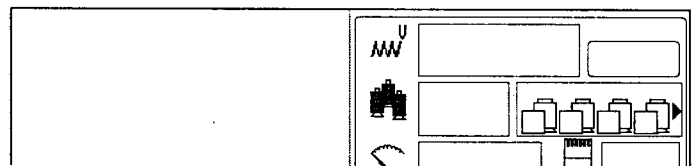

When you cannot clear by the method above (Auto)

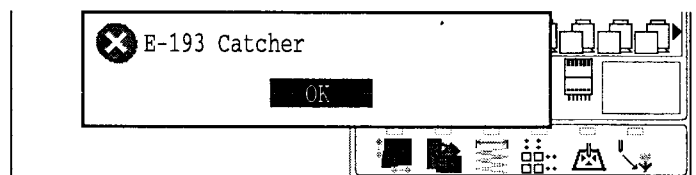



1. Press the **SET** button.

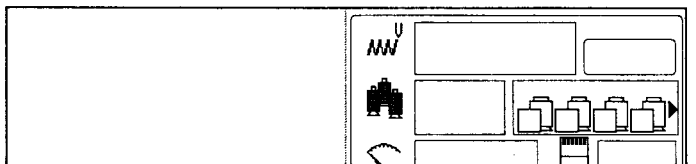

2. Press the **SET** button.

The Error status is cleared and the display shows "drive mode".



3. Refer to the page in the section (ERRORS AND WHAT TO DO), and determine what may be preventing the hook from returning to the original position, and follow the steps outlined.  24-4

● Re-Initialization of machine system

Perform this function only to fix problems with the machine.
 When performed, all settings in the "OPTION" menu are lost.
 Be sure to reset the "OPTION" menu after performing this function.

1. When the machine is stopped, press **(MENU)** and Select "OTHER" with .

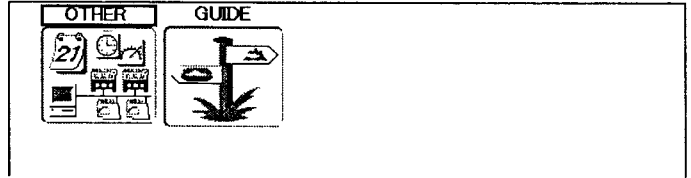

2. Press the **(SET)**.

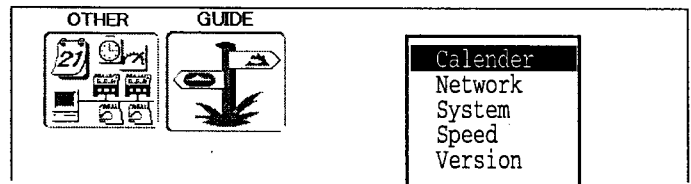

3. Select "System" with  and press **(SET)**.

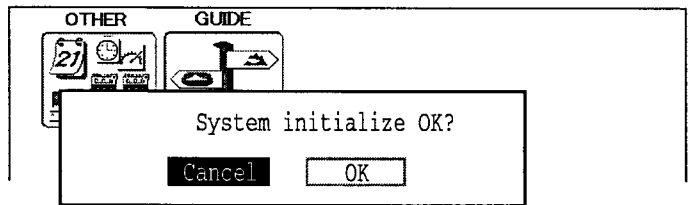

4. Select "OK" with  to carry out.

If you cancel, press **(SET)**.
 The display returns to MENU.

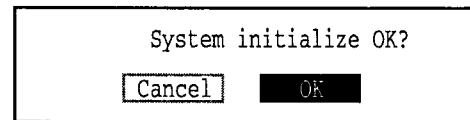

5. Press the **(SET)**.
 Formatting of the machines systems are carried out.

Indicate HAPPY logo in screen.

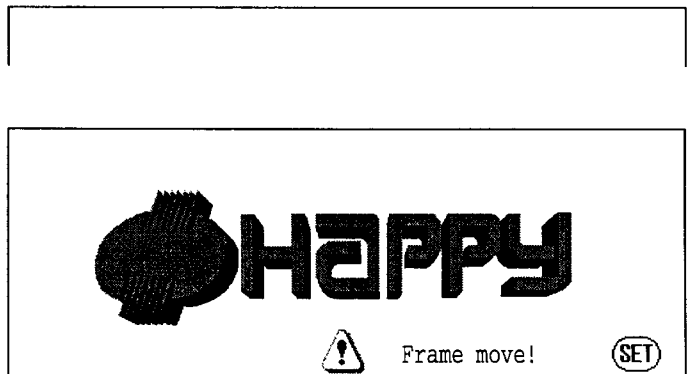

● Initializing of machine speed

If you have E-18, E-30, E-51 or E-52 while sewing, Please try initializing the machine settings.

1. When the machine is stopped, press **(MENU)** and Select "OTHER" with .

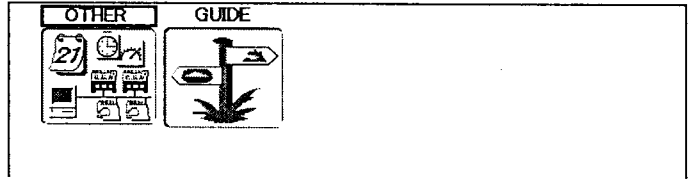

2. Press the **(SET)** button.

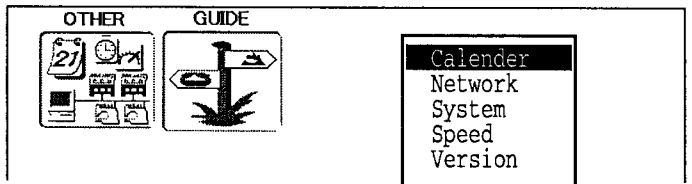

3. Select "Speed" with  and press **(SET)**.

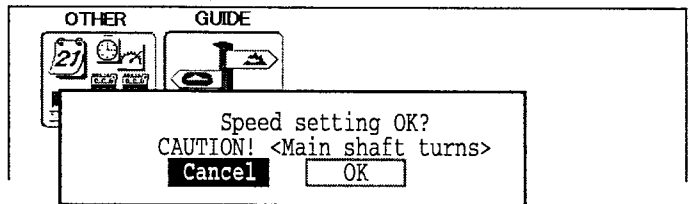

4. Select "OK" with  to execute.

Press the **(SET)** to cancel.

The display returns to menu.

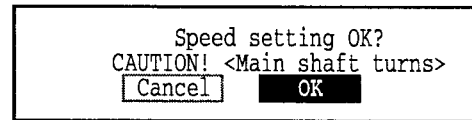

5. Press the **(SET)**.

The machine will display a warning, then start turning the main shaft automatically. The speed will slowly increase from slowest speed to maximum and then stop automatically and indicate "Complete".

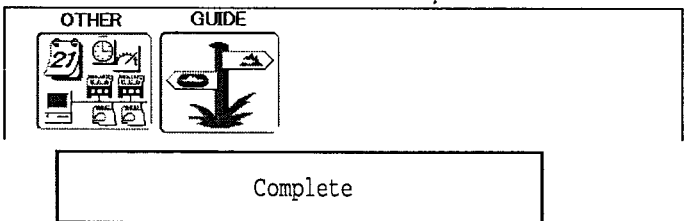

6. Turn off the power switch and turn on the power switch again.

The HAPPY logo shows onscreen.

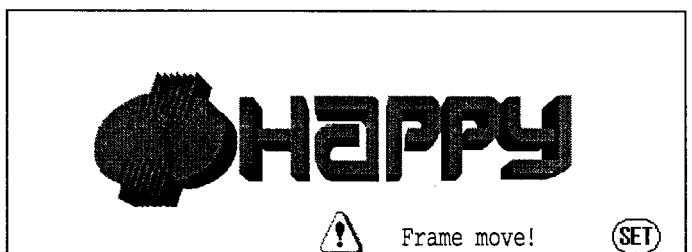
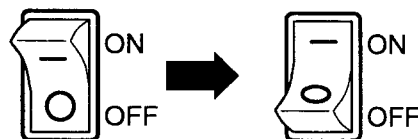
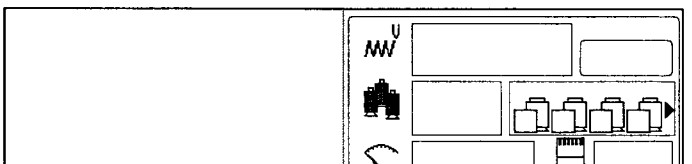

HELPFUL HINTS

26-1

PROBLEM	CAUSE	CORRECTION	PAGE
Upper thread breaks	Machine not properly threaded.	Re-thread machine.	4-6
	Needle inserted incorrectly.	Re-insert needle. (remember, needles have a front and back!)	4-1
	Thread tension too tight.	Readjust thread tension.	8-1
	Poor thread quality.	Replace with good quality thread.	
	Dry hook	Oil the hook.	23-1
	Empty stitches or continuous tiny stitches in design data.	Turn on stitch sweep function, then read design data in again.	14-4
	Thread is tangled in an upper thread cone.	Un-tangle thread.	
Lower (bobbin) thread breaks	Bobbin threaded incorrectly.	Re-thread the bobbin.	4-5
	Bobbin wound unevenly or too full.	Re-wind the bobbin.	4-4
	Thread tension too tight.	Readjust thread tension.	4-4
	Dirt on the hook.	Clean the hook.	23-2
	Dry hook	Oil the hook.	23-1
Thread break lamp lights up despite thread not being broken (False thread breaks)	Upper thread is not passing around the detecting roller.	Thread upper thread correctly.	4-7
Machine skips stitches	Needle inserted incorrectly.	Re-insert needle.	4-1
	Bent or blunt needle.	Insert new needle.	4-1
	Incorrect size of needle.	Choose correct size needle for fabric.	4-2
Fabric puckers	Machine not properly threaded.	Re-thread machine.	4-6
	Bobbin threaded incorrectly.	Re-thread the bobbin.	4-5
	Blunt needle.	Insert new needle.	4-1
	Thread tension too tight.	Readjust thread tension.	8-1
Machine makes loose stitches or loops	Bobbin threaded incorrectly.	Re-thread the bobbin.	4-5
	Machine not properly threaded.	Re-thread machine.	4-6
	Tension not adjusted properly.	Readjust thread tension.	4-5,8-1
Poor tension balance	Bobbin threaded incorrectly.	Re-thread the bobbin.	4-5
	Machine not properly threaded.	Re-thread machine.	4-6
	Dry hook	Oil rotary hook.	23-1
Poor design registration	Fabric not hooped correctly.	Set hooping correctly.	6-2,7-9
	Garment is made of elastic material.	Use correct backing and ensure that design has proper underlay.	6-2,7-9
	Hoop not installed into machine properly.	Set hoop correctly.	6-3,7-5
Needle breaks	Bent or blunt needle.	Insert new needle.	4-1
	Needle setting incorrect.	Re-insert needle.	4-1
	Thin needle against material.	Change to thicker needle.	4-2
	Poor hooping.	Re-hoop fabric.	
Machine runs with difficulty	Dirt on the hook race.	Clean rotary hook.	23-2
		Oil rotary hook.	23-1
Machine will not run	Cord not plugged into electrical outlet.	Insert plug fully into outlet.	
	Power switch is not turned on.	Turn on the switch.	3-5
	Power source fuse has blown.	Replace power source fuse (6A).	3-1
will not turn on	Emergency stop button in locked position.	Release emergency stop button lock.	3-8
Cannot see menu	Contrast setting incorrect.	Adjust LCD screen contrast	3-6

Thread break back

With this setting, drive frame backs up several stitches after a thread break before stopping.

Color change number

The Needle number (thread color) to be sewn can be set to each Color change number. For example, if a pattern is divided by a color change function in 2 places, 3 color change numbers exist in the pattern. When the needle number is set to its respective color change number, the pattern is sewn in 3 colors.

Memory pattern

Patterns stored in memory.

Start point of the frame

This is the point where the frame begins to move before the machine starts sewing.

Trace back

This is to move the frame and memory pattern in the reverse direction of sewing.

Trace forward

This is to move the frame and memory pattern towards the sewing direction.

Various function settings

A general term for Needle bar selection, Convert, Pattern adjustment, Repeat sewing, Offset and frame out which are set in the pattern data. The machine saves these function settings in a file ending with an .hp1 extension when saving a design back out to floppy disk or memory card.

Zero stitch

This is a stitch whose net movement in both the X- and Y- direction is zero, and the needle lands in the same position.

Original Point

The frame position where the machine embroiders the pattern from the beginning is automatically registered as the original point.

Stitches

This is the minimum unit within the pattern data. There are different types of such "stitches": "stitches" that command determine the sewing sequence; "functions" that dictate functions such as jumps, thread cut, etc; "sideways movement distance" and "lengthwise movement distance" that command the movement distance of the frame.

Speed limit

This is a function code that limits the highest speed. In cases where there is a need to limit the sewing speed at a specific point in a design, you can limit the speed to not exceed the speed specified by setting the appropriate function code to the desired stitch.

Auto origin

This returns the frame automatically to the original point upon finishing the embroidery.

Communication speed

This refers to the data transmission speed between the machine and a PC when connected by serial port. Higher speed settings allow faster transmission of data but also increase probability of communication error. If communication errors happen frequently, lower the communication speed.

Tubular round frame, Tubular square frame

The frames made by HAPPY and used for cylinder sewing, such as on T-shirts, bags, etc. These frames have brackets at both sides.

Data format

This is the format that the pattern data is converted into/

Color change stop

When a color change stop is assigned to a color change number, the machine embroiders the set color change and stops.

Conversion

This is a user-adjustable design setting of a given pattern that allows rotation in increments of 90 degrees.

Style 1

A B C D E	a b c d e	0 1 2 3 4
F G H I J	f g h i j	5 6 7 8 9
K L M N O	k l m n o	- , . ' /
P Q R S T	p q r s t	? ! &
U V W X Y	u v w x y	< > () _
Z	z	

Style 2

A B C D E	a b c d e	0 1 2 3 4
F G H I J	f g h i j	5 6 7 8 9
K L M N O	k l m n o	- , . ' /
P Q R S T	p q r s t	? ! &
U V W X Y	u v w x y	< > () _
Z	z	

Style 3

<i>A B C D E</i>	<i>a b c d e</i>	<i>0 1 2 3 4</i>
<i>F G H I J</i>	<i>f g h i j</i>	<i>5 6 7 8 9</i>
<i>K L M N O</i>	<i>k l m n o</i>	<i>- , . ' /</i>
<i>P Q R S T</i>	<i>p q r s t</i>	<i>? ! &</i>
<i>U V W X Y</i>	<i>u v w x y</i>	<i>< > () _</i>
<i>Z</i>	<i>z</i>	