

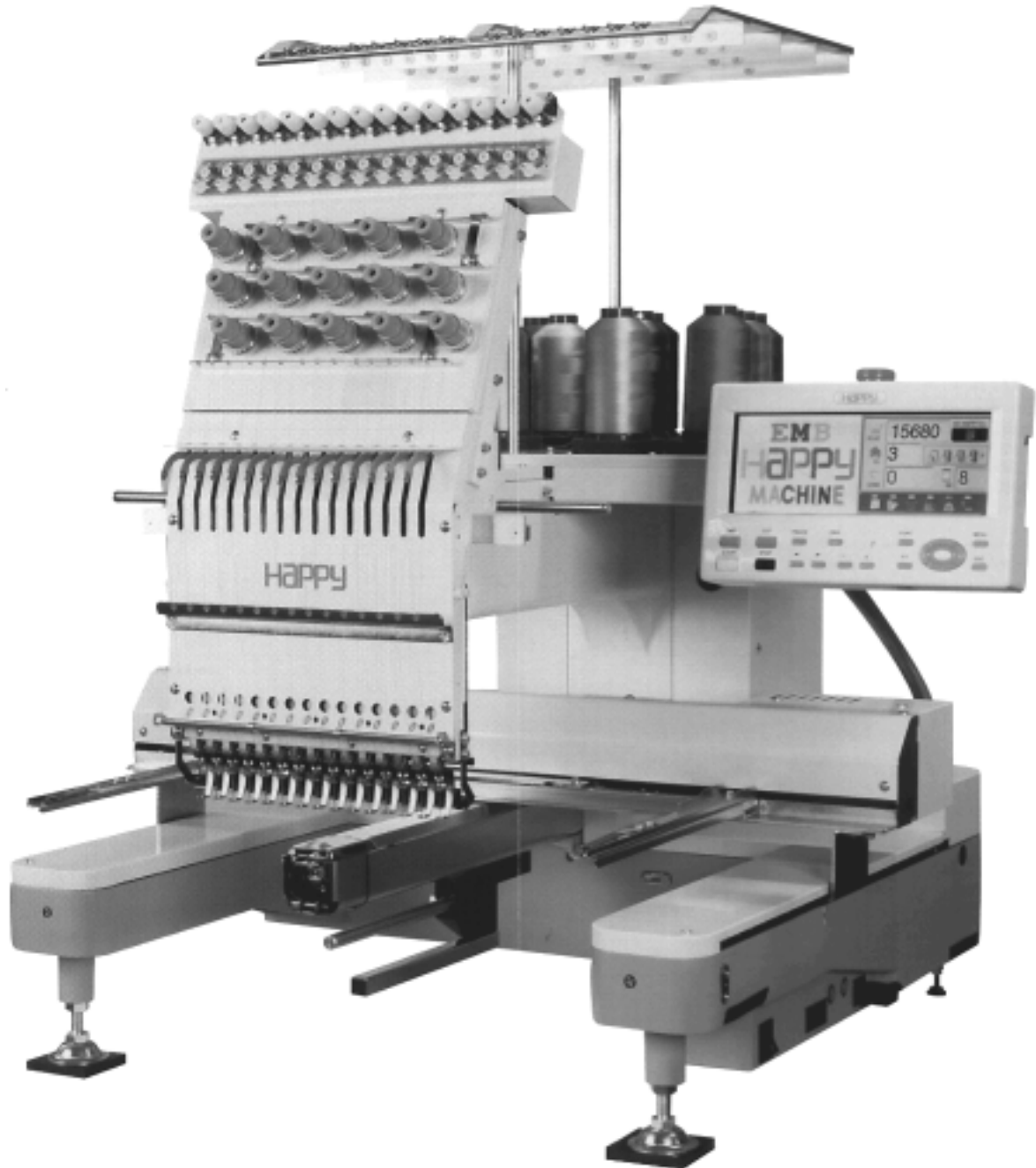

# Maintenance Manual for Embroidery Machine

## HCD-1501-40

Version 1.1



## # For safe adjustment and repair #

In order to conduct adjustment and repair safely and surely,  
please be sure to abide by what is mentioned in this manual to prevent trouble.



1. When you conduct adjustment and repair of this embroidery machine or handle electric related parts, you are required to take technical lesson in advance.
2. When you conduct adjustment and repair using this manual, please be sure to use together with instruction with it in hand.

# Please conduct in accordance with work process in this manual.

# In case there are no specific instructions or explanations in work process.  
please be sure to unplug cord from receptacle.

# When you exchange parts, please be sure to use genuine parts designated by us.

# Please never remodel the embroidery machine.

When you handle circuit boards:

# In order to prevent troubles from static electricity, please remove earth from human body.

# Please don't touch metal part of circuit board with bare hand as it will short-circuit  
and threaten to break circuit boards.

# When you removed circuits boards from the machine or you store or transport them,  
please wrap them in static electricity preventive bag and avoid to give shock.

# Index

---

	page
cover .....	1
For safe adjustment and repair .....	2
Index. ....	3~8
1 Outline of mechanism .....	9
1-1 Outline of mechanical mechanism.....	10,11
1-2 Placement of key electronic parts .....	12
2 Outer covers .....	13
2-1 Removal of thread guide ass'y, thread guide pillar and thread stand.....	14
2-2 Removal of outer covers. ....	15,16
3 Mechanical mechanism. ....	17
3-1 Basic maintenance. ....	18
3-1-1 Maintenance of thread path. ....	19,20
3-1-2 Fixing of needle. ....	21
3-1-3 Selection of thread. ....	22
3-1-4 Relation between needle and upper thread. ....	23
3-2 Fixed head.....	24
3-2-1 Exchange of crank ass'y.....	25~33
3-2-2 Exchange of rod. ....	34,35
3-2-3 Exchange of pressure foot arm ass'y .....	36
3-2-4 Exchange of pressure foot cam. ....	37,38
3-2-5 Adjustment of the lowest needle point. ....	39
3-2-6 Exchange of needle bar driver. ....	40
3-2-7 Adjustment of fixing of jump solenoid. ....	41
3-2-8 Exchange of roller shaft ass'y. ....	42
3-2-9 Adjustment of take-up lever timing.....	43
3-2-10 Check of height of pressure foot.....	44
3-2-11 Exchange / Adjustment of pressure foot .....	45,46
3-2-12 Fixing of thread catcher. ....	47

# Index

---

	page
3-2-13 Exchange of thread catcher guide.....	48
3-2-14 Disassembling and Cleaning of jump solenoid.....	49
3-3 Moving head.....	50
3-3-1 Assemble and remove moving head.....	51~53
3-3-2 Fixing of upper rail.....	54
3-3-3 Adjustment of backlash (back and forth) of moving head.....	55
3-3-4 Adjustment of needle position (back and forth).....	56
3-3-5 Check of needle position.....	57
3-3-6 Adjustment of needle height.....	58,59
3-3-7 Exchange of needle bar, needle bar spring, cushion and pressure foot block.....	60,61
3-3-8 Fixing of needle bar boss check plate.....	62
3-3-9 Exchange of take-up lever.....	63,64
3-3-10 Adjustment of thread holder.....	65
3-3-11 Exchange of majic-tape on thread holder.....	66
3-3-12 TC Thread detecting board position.....	67
3-4 Needle bar change unit.....	68
3-4-1 Fixing of needle bar change unit.....	69
3-4-2 How to take out needle bar change stop position sensor..... and needle position sensor (potentiometer)	70
3-4-3 Adjustment of needle bar change stop position sensor..... and needle position sensor (potentiometer)	71,72
3-5 Rotary hook.....	73
3-5-1 Adjustment of rotary hook timing.....	74,75
3-5-2 Adjustment of retainer on rotary hook.....	76

# Index

	page
3-6 Thread cut unit .....	77
3-6-1 Adjust for thread trim sensor and stopper .....	78,79
3-6-2 Exchange of moving knife .....	80
3-6-3 Exchange of fixed knife .....	81
3-6-4 Adjustment of moving knife and fixed knife .....	82
3-6-5 Adjustment of position of moving knife .....	83
3-6-6 Adjustment of bobbin thread holder .....	84
3-6-7 Exchange of keeper solenoid .....	85,86
3-6-8 Adjustment of position of keeper .....	87
3-7 Carriage unit .....	88
3-7-1 Adjustment of X carriage belt tension .....	89,90
3-7-2 Exchange of X carriage belt .....	91,92
3-7-3 Adjustment of Y carriage belt tension .....	93~95
3-7-4 Exchange of Y carriage belt .....	96~98
3-7-5 X carriage limit sensor replacement and adjustment .....	99
3-7-6 Y carriage limit sensor replacement and adjustment .....	100
3-8 Transmission unit .....	101
3-8-1 Adjustment of timing belt tension .....	102
3-8-2 Exchange of timing belt .....	103,104
3-8-3 Exchange of main shaft timing board .....	105
3-8-4 Adjustment of detecting slit and timing slit .....	106,107
4 Exchange and Setting of electric related component .....	108
4-1 Setting of dipswitch for CPU board. ....	109
4-2 Exchange of fuse. ....	110
4-3 How to remove Drive A Circuit Board Unit .....	111
4-4 Exchange of switching power supply and adjustment of power voltage output and of power failure detection	
4-4-1 Exchange of switching power supply .....	112,113
4-4-2 Adjustment voltage output of 24V switching power supply. ....	114
4-4-3 Adjustment voltage output of 36V switching power supply. ....	115
4-4-4 Adjustment of power failure detection .....	116
4-5 Exchange of cooling fan (2 places) .....	117

# Index

	Page
5 Parts Replacement in control box and setting. ....	118
5-1 Open and remove front panel from control box	
5-1-1 Open the front panel on the control box .....	119
5-1-2 Remove ATA LCD board .....	120
5-2 Dip switch setting for ATA LCD board .....	121
6 Inverter setting .....	122
6-1 Inverter setting	
6-1-1 Replace and wiring inverter .....	123
6-1-2 Remove Inverter. ....	123,124
6-1-3 Replace Inverter for 100-120V / FR-S510W .....	125~127
6-1-4 Replace Inverter for 200-230V / VFNC1 .....	128~130
6-2 Setting of inverter	
6-2-1 About Inverter .....	131
6-2-2 FR-S510W Parameters release the keep off setting .....	132
6-2-3 FR-S510W Setting parameters .....	133
6-2-4 FR-S510W Initialize parameters .....	134
6-2-5 VFNC1(S) Parameters release the keep off setting .....	135
6-2-6 VFNC1(S) Setting parameters .....	136
6-2-7 VFNC1(S) Setting extension parameter .....	137
6-2-8 VFNC1(S) Initialize parameters .....	138
7 Installment and setting of option unit .....	139
7-1 Installment of floppy disk drive unit. ....	140,141
7-2 Installment of extended memory board .....	142
7-3 Installment, setting and adjustment of needle sensor .....	143
7-3-1 Installment of needle sensor .....	143~147
7-3-2 Setting procedure. ....	148
7-3-3 Adjustment of optical axis. ....	149
7-4 Installment of Bobbin winder .....	150~153
8 Initialization of system. ....	154
8-1 Notice for update and Initialize machine systems .....	155
8-2 Operation order for update and Initialize machine systems. ....	156
8-3 Detail operation order for update machine systems	
8-3-1 How to Update Program for Control of ATA LCD Board .....	157
8-3-2 How to Change Language Setting .....	158
8-3-3 How to Update CPU Board Program .....	159
8-3-4 How to Update Data for Frame Driving .....	160

# Index

	Page
8-4 Initialization of memory	
8-4-1 Initialization ATA LCD board memory.	161
8-4-2 Initialization CPU board memory.	161
9 Maintenance mode	162
9-1 How to enter Maintenance mode	163
9-2 Machine—Machine movement	164,165
9-3 Memory—Initialization of design memory	166
9-4 Record—Operation data display	167
9-4-1 Total number of stitch	168
9-4-2 Record of Error occurrence	169
9-4-3 Number of occurrence in each error display	170
9-5 Setup—Machine setting	170,171
9-6 Position—Registration of coordinates for positioning sensor.	172,173
10 Revolution.	174
10-1 Setting of Revolution.	175
11 Electric system diagram	176
11-1 Electrical connection diagram	177
11-2 List of electrical connection diagrams	178
11-3 Reference diagram for wiring (AC line)	179
11-4 FR-S510W type Inverter wiring and parameter setting. (For 110V)	180
11-5 VFNC1(S) type Inverter wiring and parameter setting. (For 220 V)	181
12 Others	182
12-1 How to respond for some question ( As example step)	183
12-2 Trouble shooting	184
12-2-1 Electricity doesn't turn on	185
12-2-2 Thread break	186~190
12-2-3 Erraneous thread cut	191,192
12-2-4 Off-registration of pattern	193,194
12-2-5 Upper thread comes off from needle hole	195,196
12-2-6 Upper thread remains	197
12-2-7 Malfunction of thread break detection	198,199
12-2-8 Suspension of upper shaft	200
12-2-9 Malfunction of needle bar change	201
12-2-10 Defect on thread catcher	202

# Index

---

	Page
12-2-11 Others (Mechanical) .....	203
12-2-12 Others (Electronically) .....	204
12-3 Error .....	205
12-3-1 Error and measure .....	206~210
12-4 Reference date .....	211
12-4-1 Tables for timing / adjustment value .....	212
Back of cover .....	213

## 1. Outline of mechanism

- 1-1 Outline of mechanical mechanism
- 1-2 Placement of key electronic parts

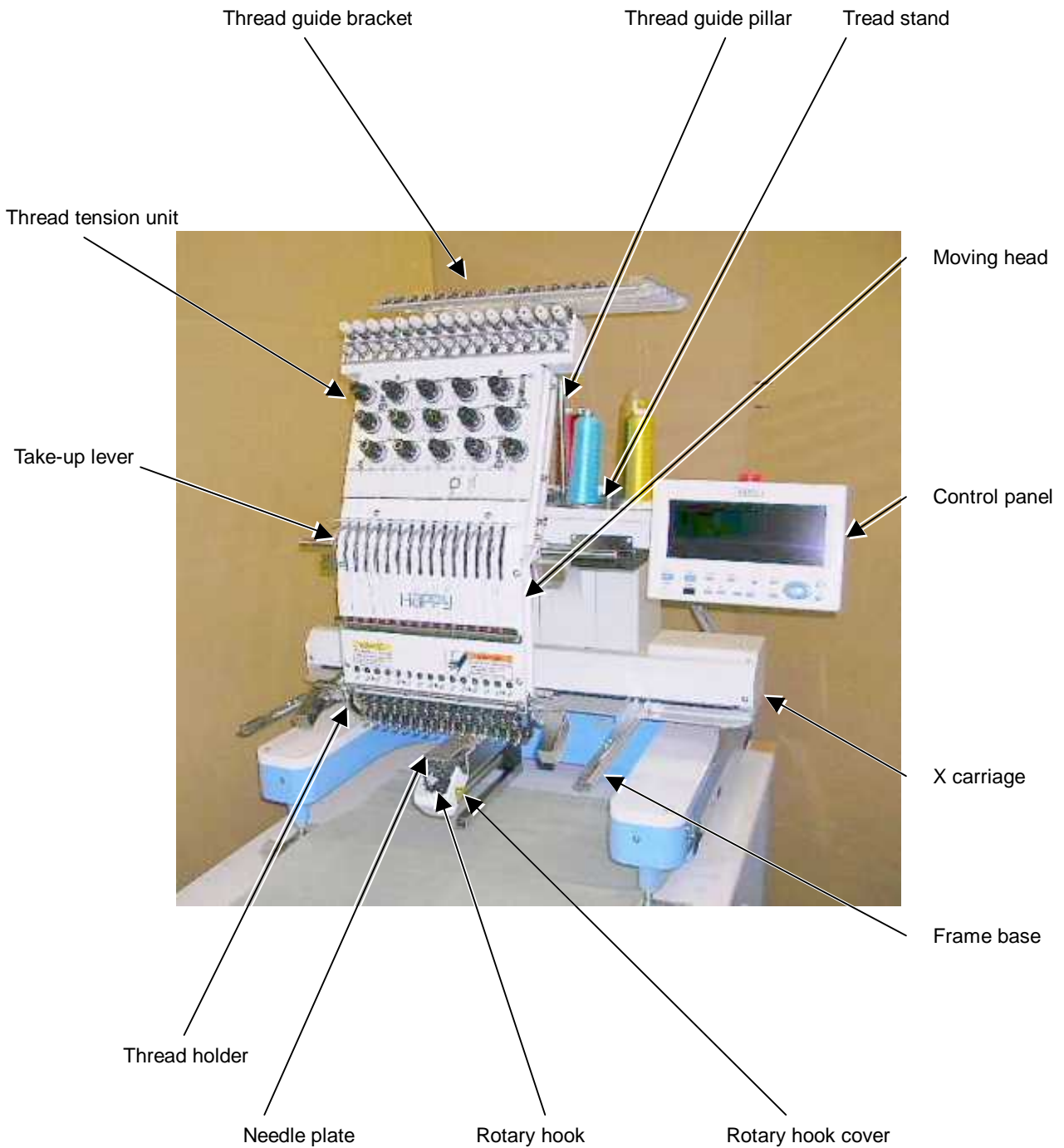

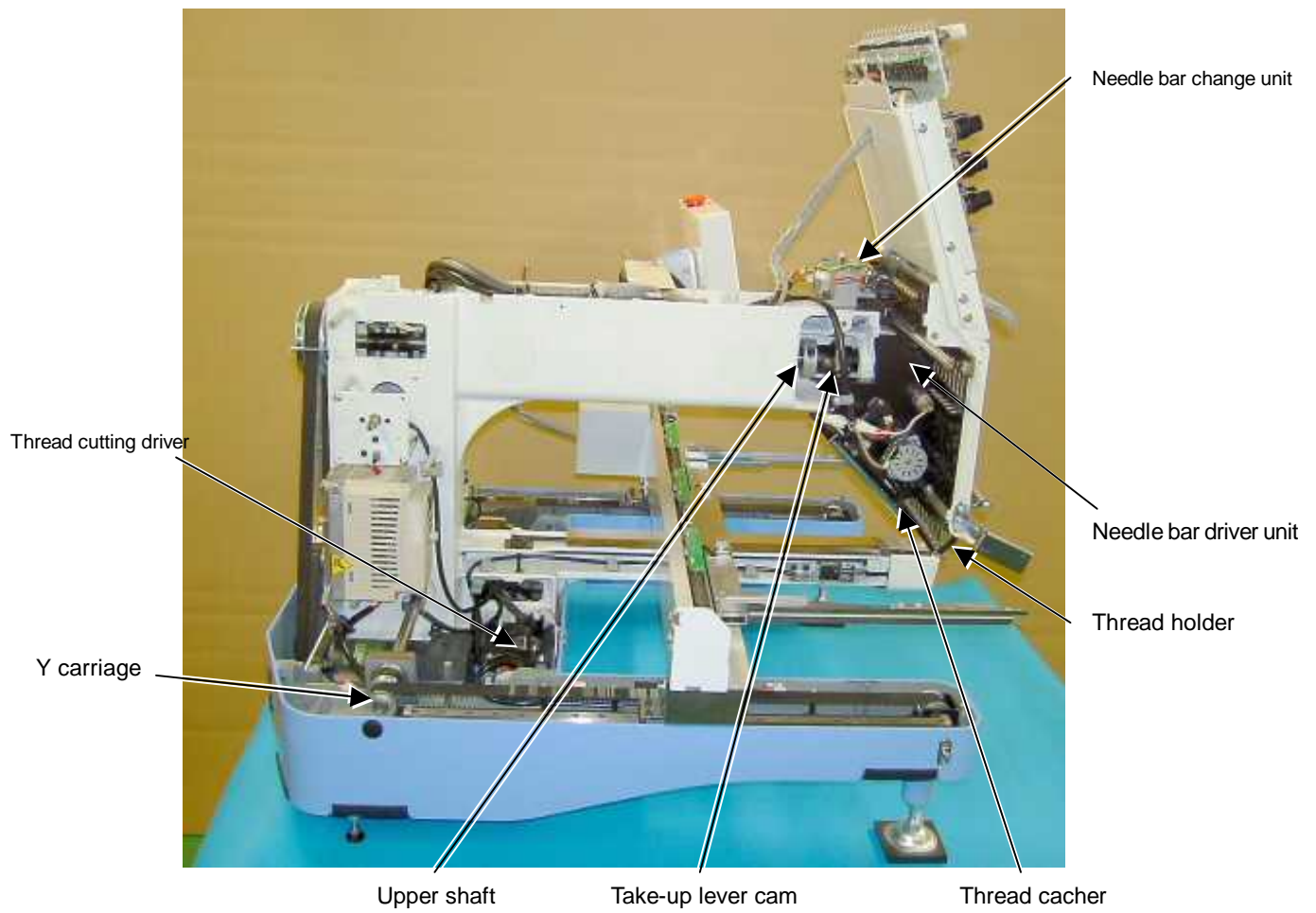

# Placement of key electronic parts

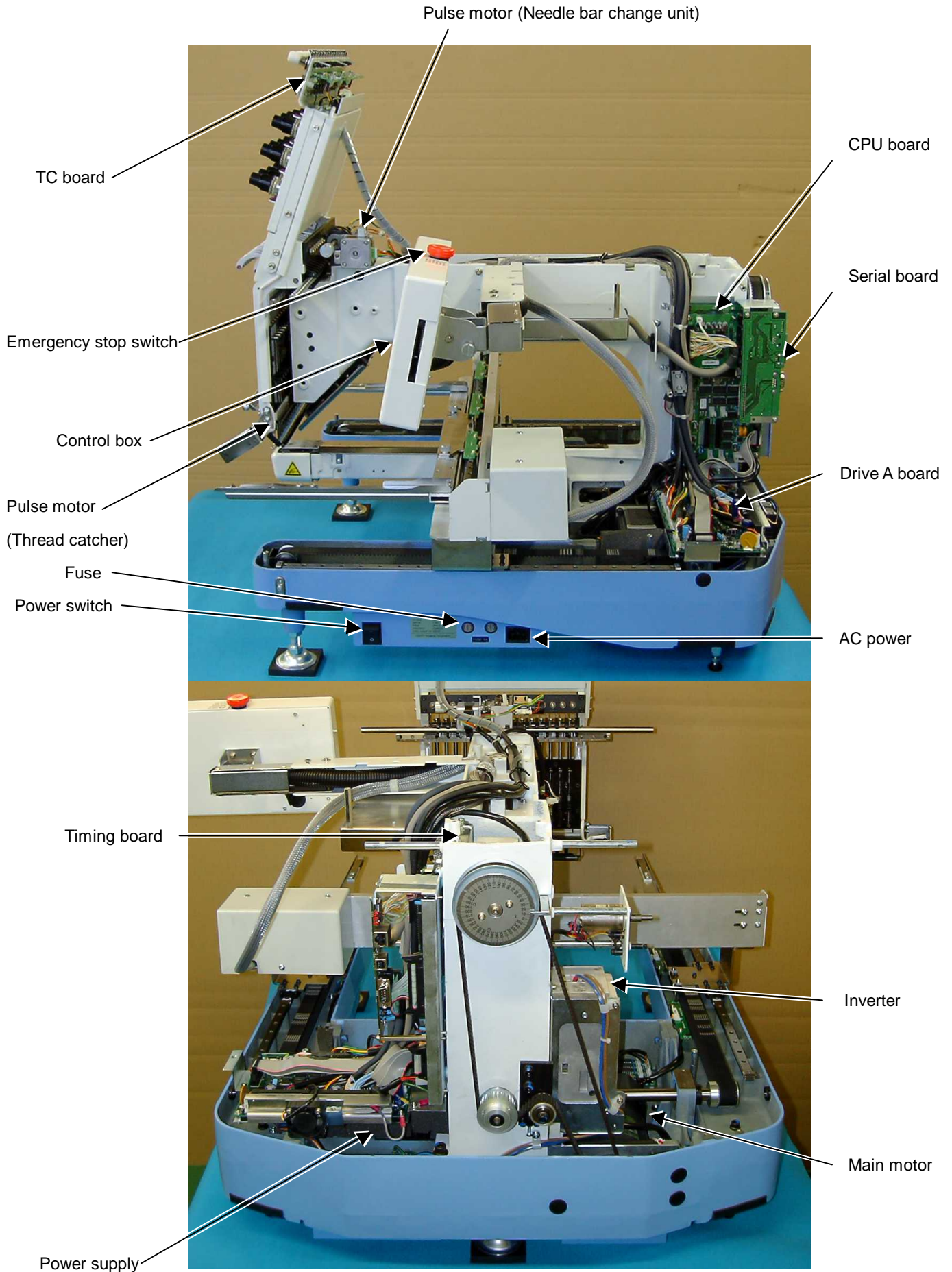

## 2. Outer covers

2-1 Removal of thread guide ass'y, thread guide pillar, and thread stand

2-2 Removal of outer covers

1. Remove thread guide bracket.



2. Remove thread guide pillar and thread stand.



3. Remove thread stand.

(Fixing screw 8pcs : Without Floppy disk drive)

(Fixing screw 9pcs : With Floppy disk drive (Option))



# Removal of outer covers

1. Remove the cover G ass'y. (Fixing screw 4 pcs)

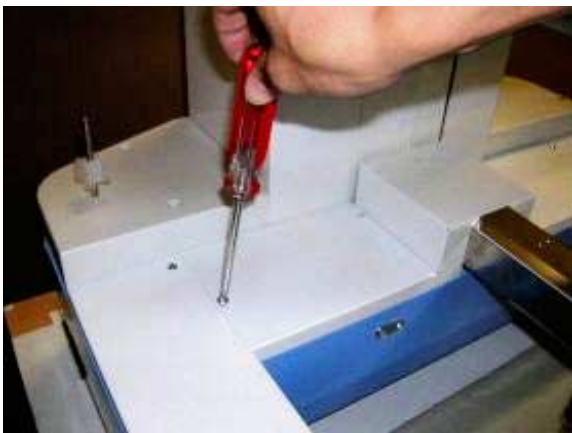

2. Remove the cover E. (Fixing screw 2 pcs)



3. Remove the cover F. (Fixing screw 2 pcs)

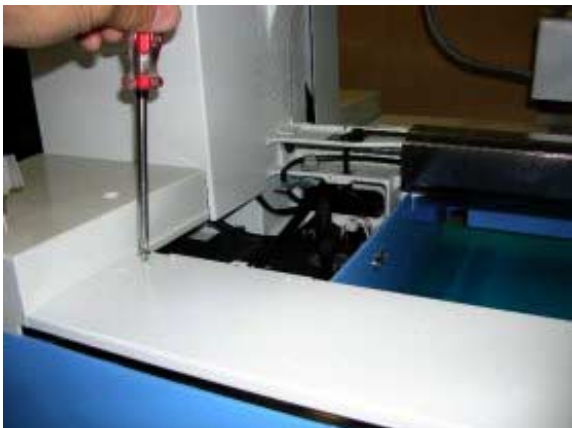

4. Remove the cover C. (Fixing screw 2 pcs)



5. Remove the cover H. (Fixing screw 6 pcs)

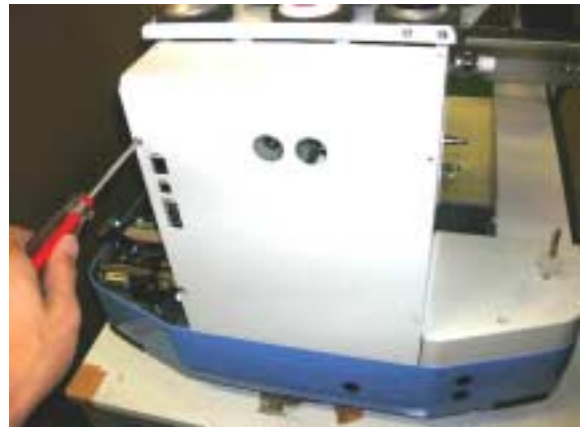

6. Remove the cover A. (Fixing screw 2 pcs)



# Removal of outer covers

7. Remove the cover D. (Fixing screw 2 pcs)

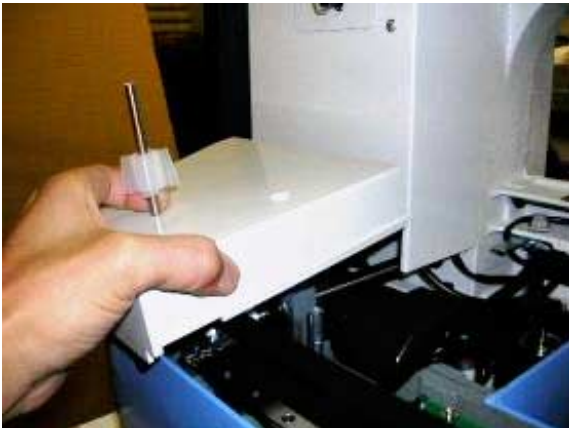

9. Remove the cover B. (Fixing screw 2 pcs)



8. Guide should be removed if there is a bobbin winder.  
(Fixing screw 1 pcs)



10. Remove the cover for needle bar change unit.  
(Fixing screw 2 pcs)



Remove the bobbin thread guide. (Fixing screw 2 pcs)



11. Remove the head left side cover. (Fixing screw 2 pcs)



12. By above process, removal of [cover] has finished.

### 3. Mechanical mechanism

3-1 Basic maintenance

3-2 Fixed head

3-3 Moving head

3-4 Needle bar change unit

3-5 Rotary hook

3-6 Thread cut unit

3-7 Carriage unit

3-8 Transmission unit

## 3-1 Basic maintenance

3-1-1 Maintenance of thread path

3-1-2 Fixing of needle

3-1-3 Selection of thread

3-1-4 Relation between needle and upper thread

# Maintenance of thread path

3-1-1

In a bid to prevent poor sewing finish or thread break, please keep places where thread contacts in the best condition.

1. Thread tension, detecting roller, thread adjusting spring
  - a) Revolution must be smooth
  - b) No sticking of lint or dust
  - c) Confirm "Thread adjusting spring" working correctly.



- 
2. Holes on thread guide plate
    - a) No burr and crack



- 
3. Ceramic and rim of take-up lever
    - a) No burr and crack



4. Thread path in lower side and needle holder.
  - a) No burr and crack



- 
5. Needle
    - a) Needle tip shouldn't be warped or bent.

When you slide needle tip on surface of nail and if the nail gets scratched.

needle tip is warped. Please exchange it with new one.



Please place needle on flat surface and check clearance (A) from side.

If clearance is not equal, needle is bent.

Please replace it with new one.

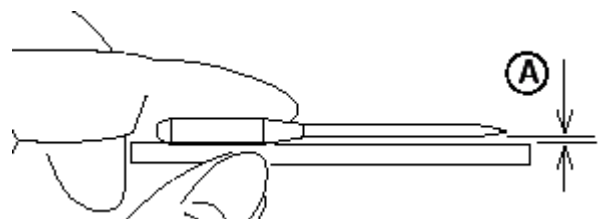

## 6. Needle plate

- a) No burr and crack in needle hole and around it.

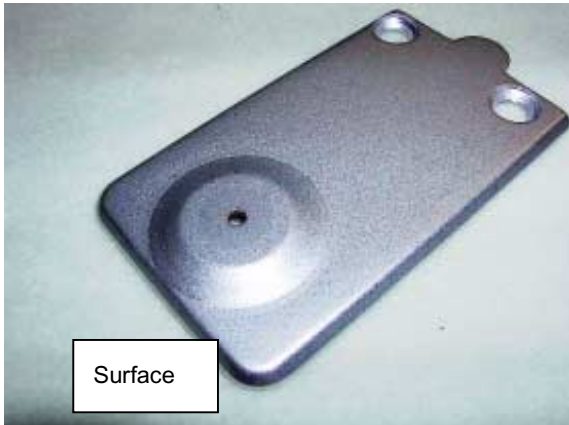

## 7. Pressure foot

- a) No burr and crack inside hole
- b) Not bent



## 8. Rotary hook

- a) No burr and crack.
- b) Hook point not warped.
- c) Backlash between bobbin case holder and outer hook should be less.



## 9. Keeper

- a) No burr and crack on tip.



# Fixing of needle

3-1-2

1. In order of (1)-(4), please remove and fix needle.

- (1) Loosen screw holding needle.
- (2) Remove needle.
- (3) Insert needle till it goes to the end.
- (4) Tighten screw holding needle.

Fix needle so that needle groove faces front.

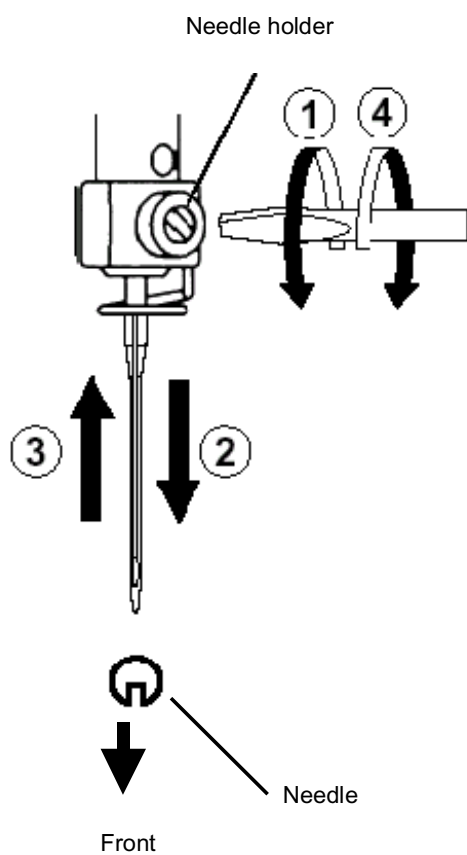

## 1. Selection of upper thread.

### <Description>

Please select considering cloth, design of pattern and flavour etc.

### <Thickness>

Please refer to [Relation between needle and upper thread 3-1-4].

### <Twist>

Z twisted thread is to be used.

(As rotary hook turns left- wise, Z twisted thread can prevent loosening of twist)



Z-twisted  
(Left - twisted)



S-twisted  
(Right - twisted)

---

## 2. Selection of lower thread.

Basically please use cotton thread (#80-120), #120 is recommendable.

Pay attention to the following in selection.

# Thickness should be equal.

# When it is lightly stretched. it doesn't break easily.

# In process of time, it doesn't get inferior.

Commercially available paper bobbin can be used, but please select thread with thickness corresponding to cotton thread (#80-120).

# Relation between needle and upper thread

## 1. Description of needle

Basically please use [DB X K5] in standard accessory.

If description or thickness of cloth doesn't suit needle size, poor sewing finish / thread break / skipping will occur.

Therefore careful attention is required in selecting needle.

## 2. Relation between needle and upper thread will be found below. (Representative example is shown.)

Needle - Size is [#11] in standard accessory.

If necessary, please select in accordance with description of thread and cloth.

Thread - In case needle size is [#11], if thread is rayon, [#120] is recommendable.

Relation between needle and upper thread

Needle Size		Description of upper thread and thickness			
Organ	German	Cotton	Silk	Polyster	Rayon
8	60	100-130	140-160	150-200	50-70
9	65	70-80	100-120	130-150	70-100
10	70				
11	75	50-60	80-100	100-130	100-130
12	80				
13	85				
14	90	36-40	60-70	80-100	130-150
16	100	30-36	50-60	60-80	150-160
18	110	24-30	40-50	50-60	180-230

Scope to be used for general embroidery

Denier(d)

If needle size and thickness of thread don't match, following problem will be likely to occur.

- Thread break
- Skipping
- Poor sewing finish

## 3-2 Fixed head

- 3-2-1 Exchange of crank ass'y
- 3-2-2 Exchange of rod
- 3-2-3 Exchange of pressure foot arm ass'y
- 3-2-4 Exchange of pressure foot cam
- 3-2-5 Adjustment of the lowest needle point
- 3-2-6 Exchange of needle bar driver
- 3-2-7 Adjustment of fixing of jump solenoid
- 3-2-8 Exchange of roller shaft ass'y
- 3-2-9 Adjustment of take-up lever timing
- 3-2-10 Check of height of pressure foot
- 3-2-11 Exchange and Adjustment of pressure foot
- 3-2-12 Fixing of thread catcher
- 3-2-13 Exchange of thread catcher guide
- 3-2-14 Disassembling and Cleaning of jump solenoid

# Exchange of crank ass y

3-2-1

1. Referring to [3-3-1 Assemble and remove moving head], remove moving head.

2. Remove it by holding moving head up.

<Caution> Confirm that hook is apart from thread holder.



3. Remove jump solenoid cable, thread catcher cable.

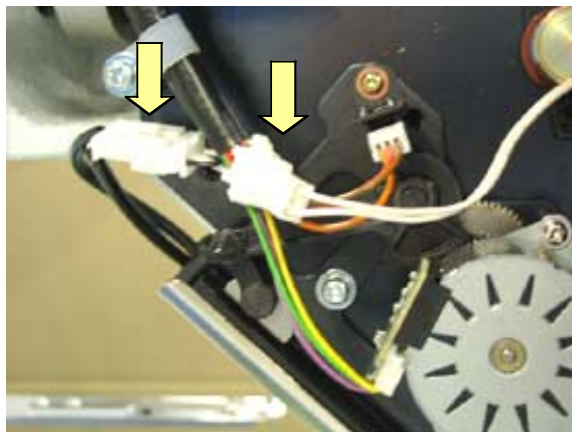

4. Remove thread catcher sensor cable, motor cable.

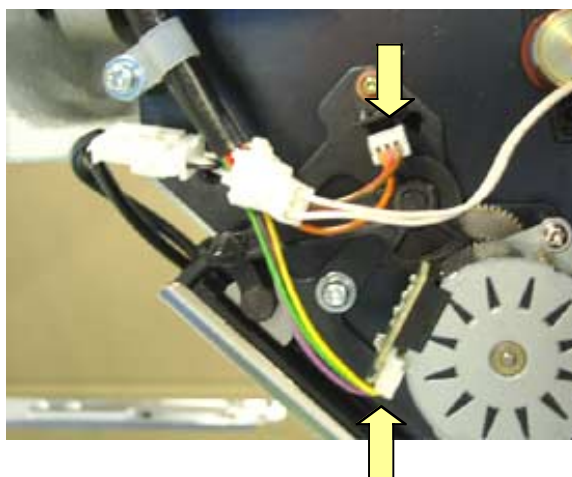

5. Remove clamp of Jump solenoid cable and thread catcher cable.



# Exchange of crank ass y

6. Remove face plate (left). (Fixing screw 3 pcs)

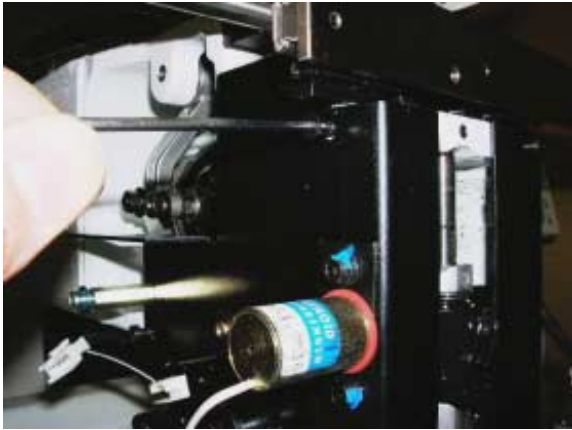

7. Remove head shaft. (Fixing screw 2 pcs)



7. Remove face plate (right). (Fixing screw 2 pcs)



<Caution>Head shaft should be taken off upward.



8. Remove upper rail. (Fixing screw 2 pcs)



# Exchange of crank ass y

10. Remove needle bar driver ass'y.



12. Take off setscrew for bearing. (setscrew 2 pcs)



11. Remove rod ass'y. (Fixing screw 2 pcs)



13. Remove take-up lever crank. (Fixing screw 1 pcs)



<Caution>Remove crank ass y from guide rail.



14. Pull out Take-up lever shaft and take off the crank ass'y.



# Exchange of crank ass y

15. Loosen the screw on fasten collar with barrel cam.



18. Remove detecting board bracket. (Fixing screw 2 pcs)



16. Loosen the screw on upper shaft collar.  
(Fixing screw 2 pcs)



19. Loosen the screw on slit disc. (Fixing screw 1 pcs)



17. Remove timing detecting board. (Fixing screw 2 pcs)



20. Loosen the screw on timing collar. (Fixing screw 1 pcs)



# Exchange of crank ass y

21. Loosen the screw on upper shaft collar.  
(Fixing screw 2 pcs)



22. Loosen the screw on drive pulley (upper).  
(Fixing screw 2 pcs)

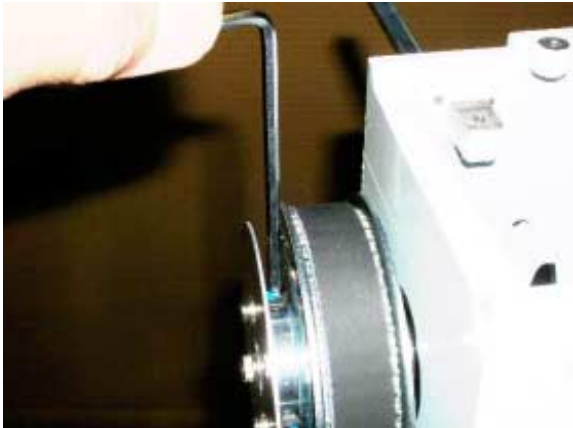

23. Remove pointer. (Fixing screw 1 pcs)



24. Check clearances between tension ass y and tension block for 6.5mm to 7.0mm.

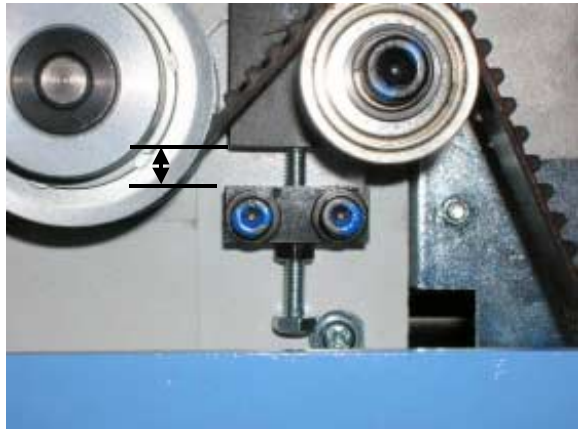

25. Loosen the screw on tension shaft ass'y.  
(Fixing screw 2 pcs)

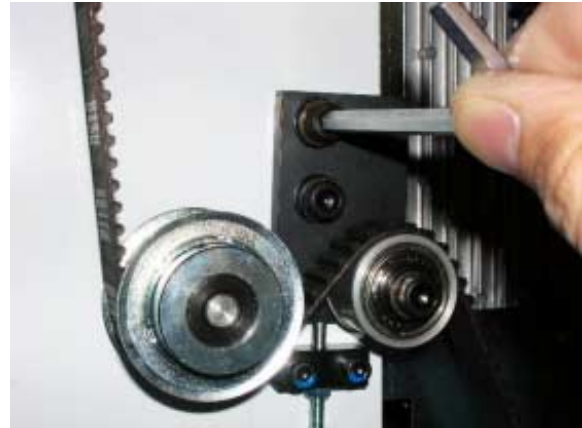

26. Loose fixing nut of tension block about 60 degrees.

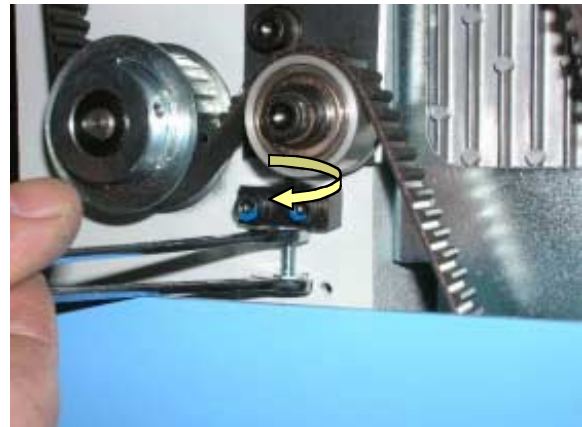

# Exchange of crank ass'y

27. Loosed the adjusting bolt.

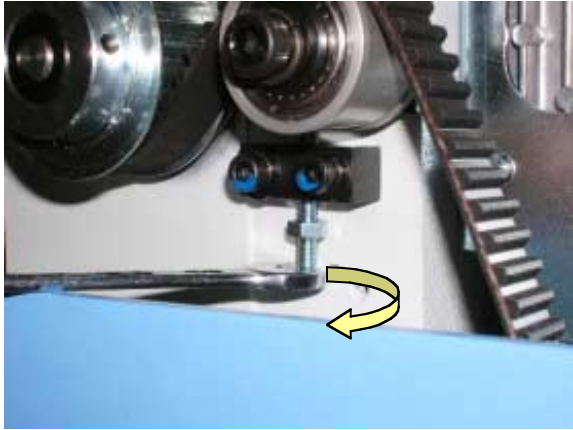

30. Slide crank ass'y in upper shaft to front side of machine.

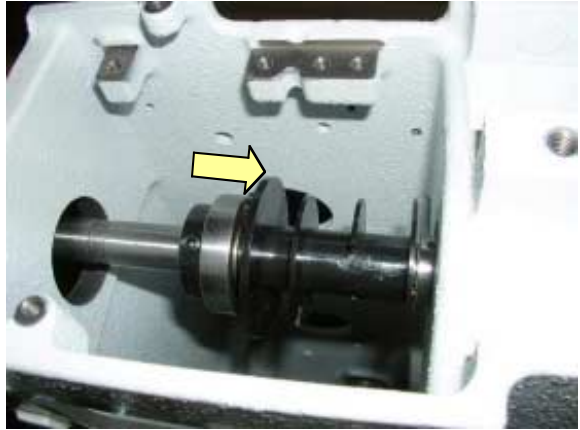

<Caution> Slide crank ass'y till touch to the machine body.

28. Take off the belt.

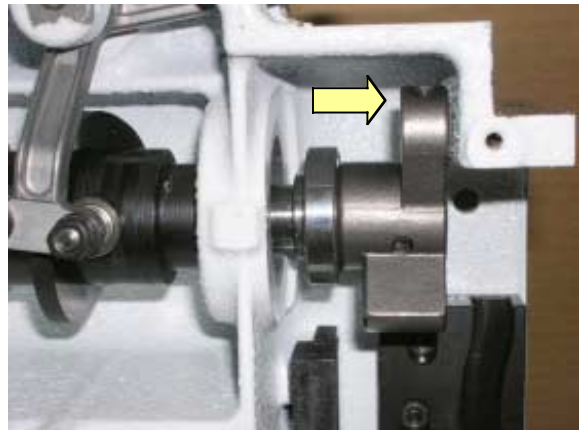

29. Remove drive pulley (upper).



31. Turn crank ass'y to following picture position.  
( Dose not touch crank ass'y to machine body at this position)



## Exchange of crank ass'y

32. Please pull out cxlank Ass'y on upper shaft slowly.



33. Please slide and off upper shaft collar, slit, Timing slit and take up lever cam from Clank ass'y



<Caution> Please care for some damage. because Timing slit is very thin and weak.



34. Remove crank ass'y.



<Caution> Dose not touch clank ass'y to machine body at this position)

35. Put parts once removed back in reverse order.

For adjusting fixing of each unit, please refer to process to adjust fixing of each unit.

# Exchange of crank assy

<Important> Pay attention to following (1) - (4)

(1) Position of Upper shaft collar to same face bearing and bearing boss.

Center bearing



Rear bearing



(2) Position of upper belt pulley.

Touch belt pulley to upper collar and fix screw to flat face on upper.

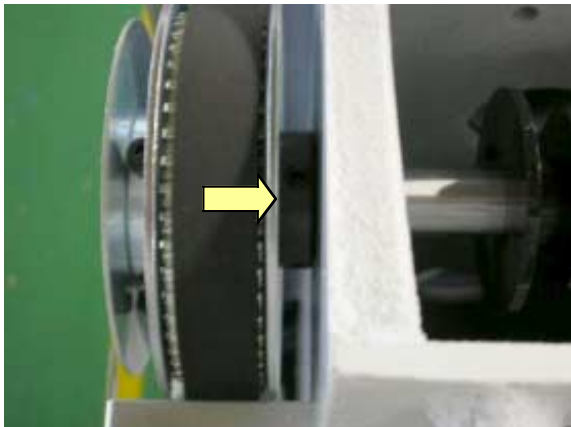

<Caution> Fix and tight setscrew to flat face on upper shaft.

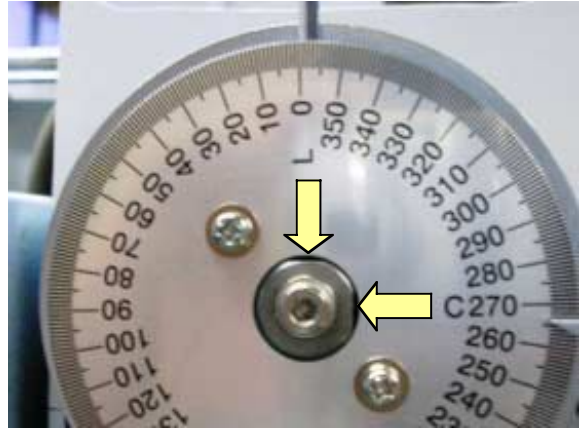

(3) Position of Face plate (left) close to rear and under side then fix screw.

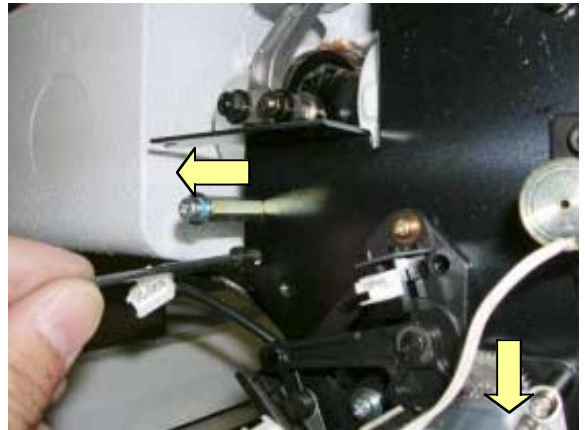

(4) Position of Face plate (right) close to left side then fix screw.

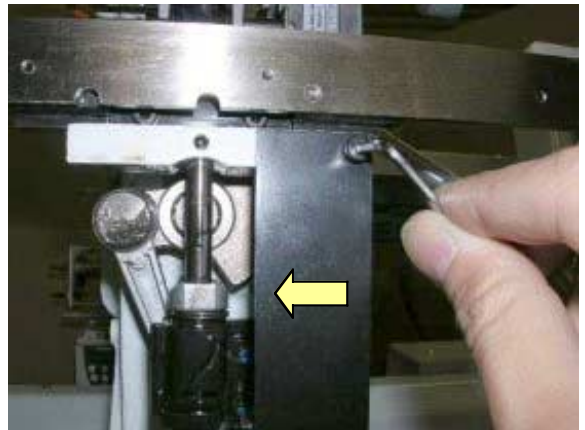

41. Please check and adjust the following timing to finish.

(1) lowest needle point (Adjusting of pointer)

(2) upper shaft timing (L point, C point)

(3) Take-up lever timing

(4) Shuttle hook timing

(5) Thread cut timing

(6) Fixing of jump solenoid

# Exchange of rod

1. Referring to [3-2-1 Exchange of crank ass'y], remove moving head.

Moving head



Face plate (left)

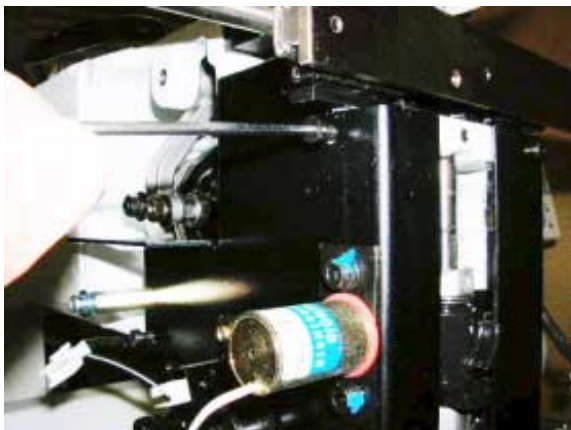

Needle bar driver ass'y



2. Remove Screw on crank pin and take off "Rod ass'y" .



3. Take off rod from guide rail.



4. Loosen screw on rod. (Fixing screw 2 pcs)



## Exchange of rod

5. Remove rod.

<Caution> Two plastic thrust washers in crank ass'y.

Please care dose not lose.

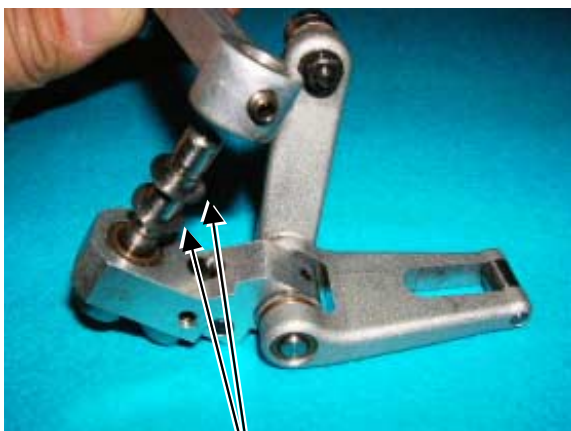

Plastic thrust washer

6. Install good parts.

At this time, put grease to bering of rod.

<Grease> [Shell alvania EP Grease2](#) [CODE 613132](#)

Equivalent brand.



7. Put each unit back to where it was according to manual.

# Exchange of pressure foot arm ass'y

1. Referring to [3-2-1 Exchange of crank ass'y], remove moving head, face plate (left), needle bar driver ass'y and Rod.

Moving head



Face plate (left)



Needle bar driver ass'y



Rod



2. Remove pressure foot arm ass'y. (Fixing screw 2 pcs)



3. Install good parts.

<Caution> Please fix Arm shaft to even stick out from bush.



4. Put each unit back to where it was according to manual.

# Exchange of pressure foot cam

1. Referring to [3-2-1 Exchange of crank ass y], remove moving head, face plate (left), needle bar driver ass'y and Rod.

Moving head



Face plate (left)



Needle bar driver ass'y



Rod



2. Remove pressure foot cam. (Fixing screw 3 pcs)



3. fix good parts as temporally tight screw.

Please check bump 2mm between front of presser foot cam and front face of fixed head.

Put on grease to presser foot cam.

<Grease>[Shell alvania EP Grease2](#) [CODE 613132](#)

Equivalent brand.



# Exchange of pressure foot cam

4. Install rod ass'y.

Should not have gap between a rod ass'y and washer.  
Also rod should work smoothly.



# In case has gap between a rod and washer, machine makes noise.

5. Set dial disc to [ L + 0 degrees ].



In this time, please check distance between upper face of presser foot and bottom face of fixed head to [25.5+/-0.2mm].

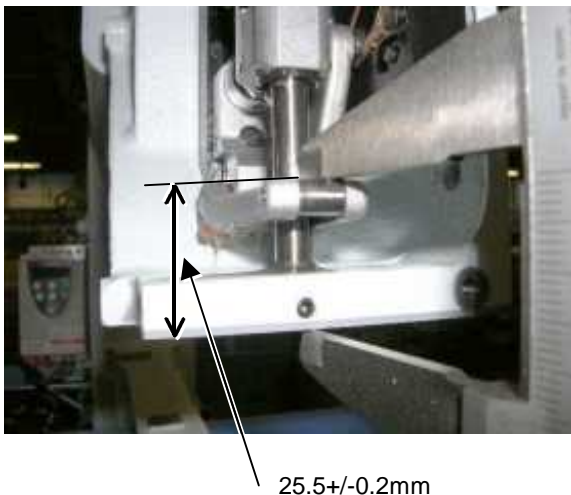

6. Set dial disc to [ L + 60 degrees ].



In this time, please check distance between upper face of presser foot and bottom face of fixed head to [26.5+/-0.2mm].



7. After check item 5 and 6 then tight screw completely for fix take-up lever cam.



8. Put each unit back to where it was according to manual.

# Adjustment of the lowest needle point

3-2-5

1. Turn upper shaft so that needle bar driver ass'y comes in the bottom.



In case there is moving head, bring needle bar to lowest point.



2. Please use dial gauge for strict checking.  
Please see that timing on dial disc comes to [0 degree] when dial swings in highest value.

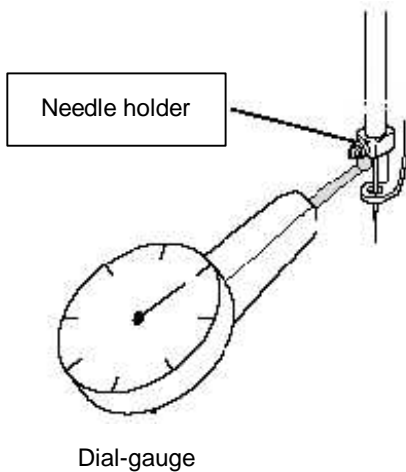

3. Please check indicator to [0 degree] completely.  
In case of dose not match pointer and [0 degree line], please adjust pointer position to just on line.



4. Referring to [3-8-4 Adjustment of detecting slit and timing slit], check timing and adjust, then finish this process.

5. Please check and adjust the following timing to finish.
  - (1) Take-up lever timing
  - (2) Shuttle hook timing
  - (3) Thread cut timing
  - (4) Fixing of jump solenoid

# Exchange of needle bar driver

3-2-6

1. Referring to [3-2-1 Exchange of crank ass'y], remove moving head, face plate (left) and needle bar driver ass'y.

Moving head



Face plate (left)



Needle bar driver ass'y



2. Install good parts.

At this time, put grease to groove of rod shaft.

<Grease> [Shell alvania EP Grease2 CODE 613132](#)

Equivalent brand.

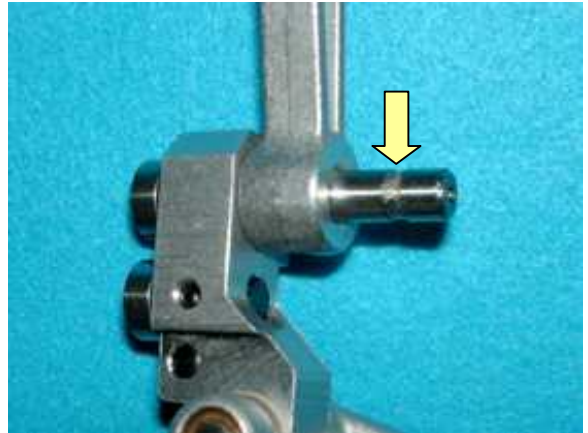

3. Put each unit back to where it was according to manual.

<Caution> Please fix top of head shaft position lower than ditch of oiling.

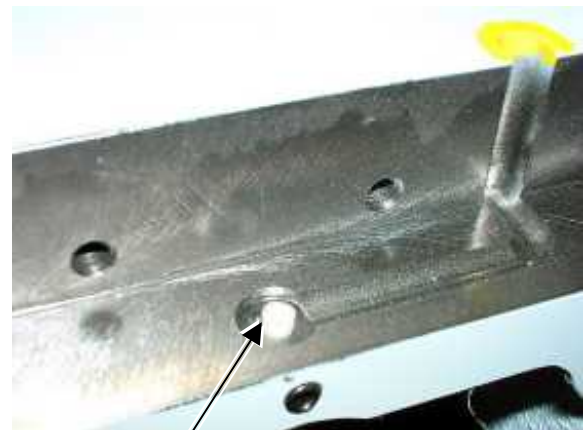

Top of head shaft

# Adjustment of fixing of jump solenoid

3-2-7

1. Referring to [3-3-1 Assemble and remove moving head], remove moving head.

Moving head



- 
2. Remove jump solenoid ass'y. (Fixing screw 2 pcs)



3. Install good parts.

Please check Jump solenoid position.

Turn main shaft till touch plunger of jump solenoid and needle bar driver and check main shaft indicator.

Should be between 75 to 77 degrees.

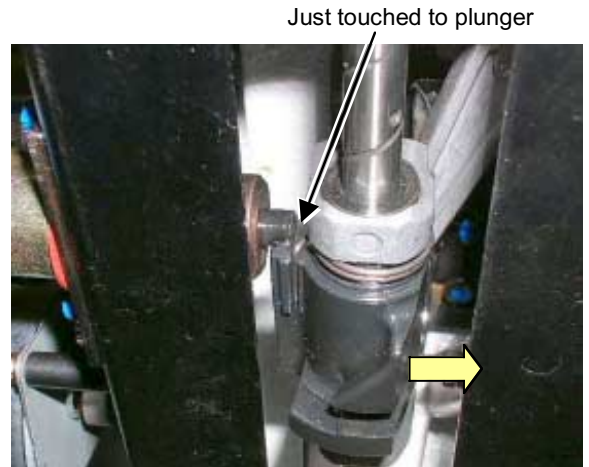

<Dubble check> Please double check Jump solenoid position by following test.

Continually fillip needle bar driver to arrow direction while main shaft turning and hearing plunger touch ing noise.

Should change noise between 75 to 77 degrees shaft position.

- 
4. Please put parts back in reverse order to finish.

For adjustment of fixing of each unit, please refer to process to adjust fixing of each unit.

# Exchange of roller shaft ass'y

3-2-8

1. Remove take-up lever crank ass'y.

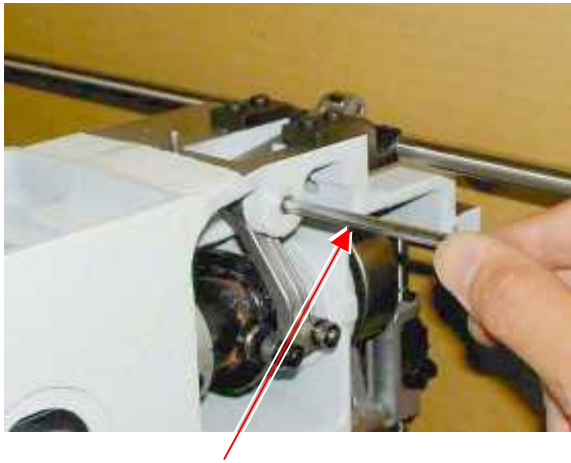

Push take-up lever shaft by slender shaft  
(Hexagon wrench etc.)

2. Exchange roller shaft ass'y



3. Insert bering positioning gauge [4.85mm] between bering and bering, and then tighten roller shaft ass'y.

Please adjust roller shaft for machine rear side ways.

This roller shaft ass'y is eccentricity.

Turn lean screw and just touch roller to gauge.

Bering positioning gauge [4.85mm]

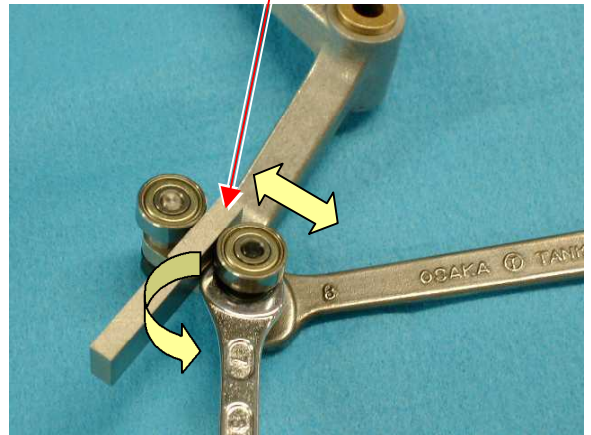

4. Return take-up lever crank ass'y to previous place to finish.

Should gap between chassis and take-up lever crank to 0.03mm.

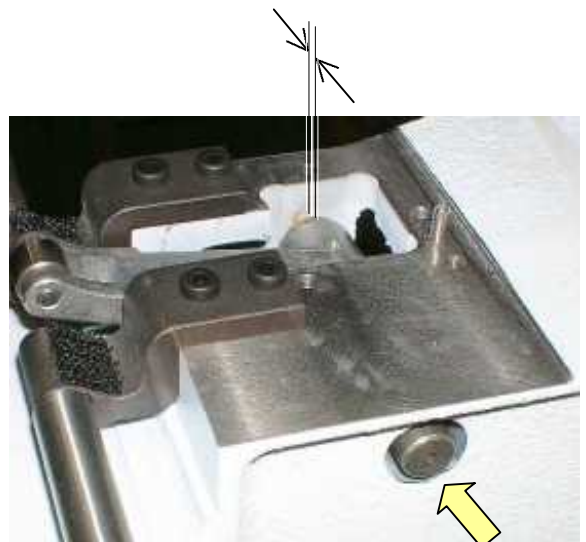

Please push to arrow ways.

< Check >

Please check non gap between roller and take-up lever cam on whole revolute main shaft.

# Adjustment of take-up lever timing

1. Loosen screw on take up lever barrel cam.



2. Set dial disc to [ 0 degrees ].



3. Insert positioning pin from right side.



4. Turn take up lever barrel cam slowly and insert positioning pin into pin groove.

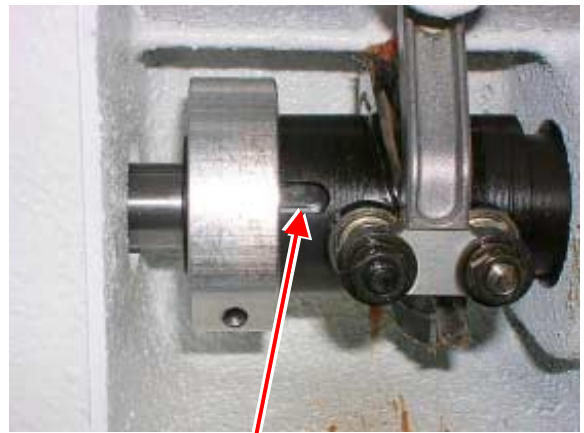

Pin groove

5. Tighten screw.

Please set position of slit on Fasten collar and Lever barrel cam.

<Important>

Rotate the Take up lever barrel cam clockwise until pin ditch touches to positioning pin then tighten the screw. (No gap between take-up lever barrel cam and crank)

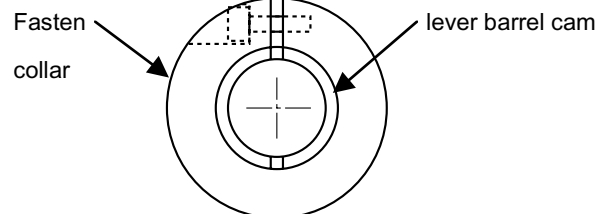
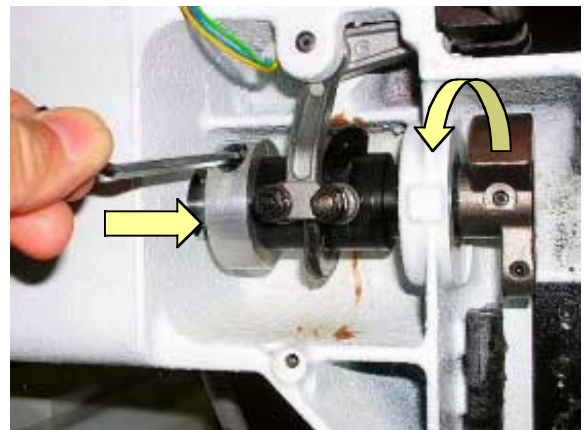

6. Pull out positioning pin.

7. Turn upper shaft and set dial disc to [C] to finish.

## Check of height of pressure foot

### 1. Bring needle bar down.

Pick needle holder and down hardy.



### 2. Turn upper shaft and set dial disc to [ 0 degree ].



### 3. Insert [Gauge 1.2mm] between needle plate and pressure foot.

No gap between gauge and pressure foot or needle plate, will be OK.



### 4. If wrong space (not 1.2mm), please adjust height of pressure foot guide bar.

Please refer to [3-2-11 Exchange and Adjustment of pressure foot].

# Exchange and Adjustment of pressure foot

3-2-11

1. Remove thread guide plate B ass'y. (Fixing screw 2 pcs)



2. Remove front panel. (Fixing screw 2 pcs)



3. Remove lower front panel. (Fixing screw 2 pcs)



4. Remove needle, needle holder and cushion.

<Caution> Please care when remove Needle holder, pop down Pressure foot.



5. Remove pressure foot. (Fixing screw 1 pcs)



6. Install good parts.



# Exchange and Adjustment of pressure foot

3-2-11

7. Please set needle and needle clamp.

For set needle, please reference [3-1-2 Fixing of needle].

8. Adjust needle height.

Please refer to [3-3-6 Adjustment of needle height].

9. Bring needle bar down.



10. Turn upper shaft and set dial disc to [ 0 degree ].



11. Insert [Gauge 1.2mm] between needle plate and pressure foot.

1.2 mm is standard, But please adjust depends by thick of material.



12. Tighten fixing screw for pressure foot.

(Fixing screw 1 pcs)

At this moment, no gap between gauge and pressure foot or needle plate.



13. Return lower front panel, front panel and thread guide plate B to previous places to finish.

# Fixing of thread catcher

1. Just loose screw of sensor for thread catch unit.

Move Rod to arrow direction for withdraw thread catch hook.

Then adjust sensor position to enter the detecting plate to sensor 1/3pile upped position.

Rod Set screws Detecting plate

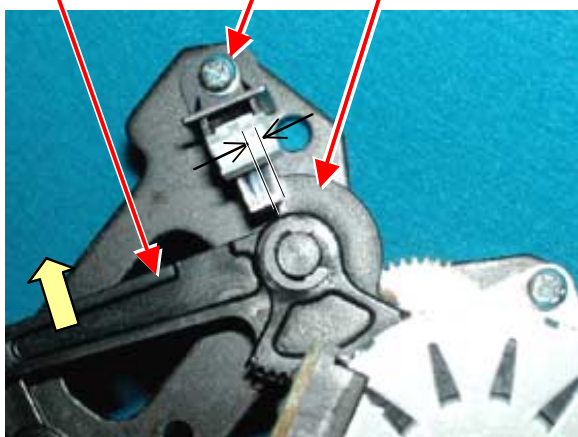

2. Install thread catcher tentatively.

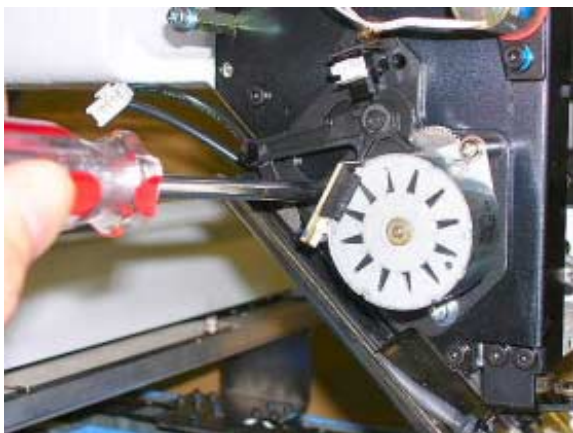

3. Tighten thread catcher pushing it upward and forward.  
(As shown an arrow.)

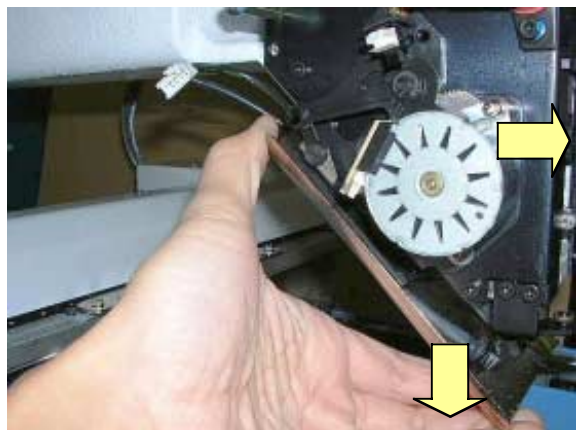

4. Turn on the power. After the program start up, press **MENU** button.

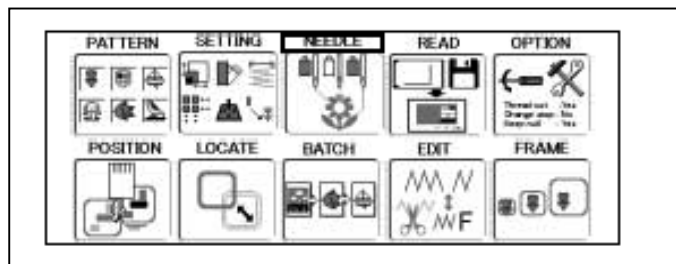

5. Press **OTHER** to select OTHER window and press **SET** button.  
Displayed as bellow.

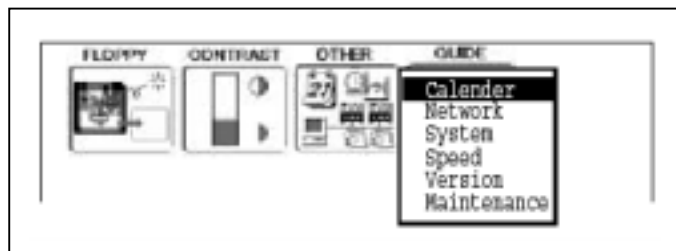

6. Press **MAINTENANCE** to select Maintenance window and press **SET** button.

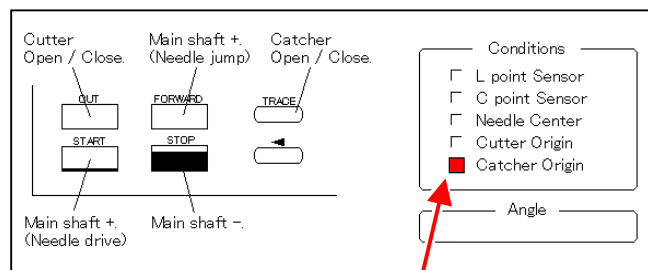

Catcher origin lamp

7. Move thread catch hook and stop on fitting position "rear line of thread holder" and "catching follow of hook".  
At this time, should change "Catcher origin lamp" to off (white) from on (Red).

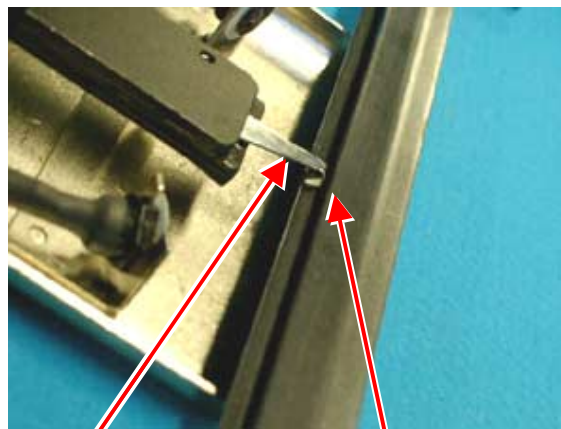

Hook Rear line of thread holder

8. Continue to conduct [Adjustment of thread holder].

When you adjustment of thread holder, in case of adjust again thread catcher. (Follow in [3-3-10 Adjustment of thread holder])

# Exchange of thread catcher guide

3-2-13

1. Remove guard plate.

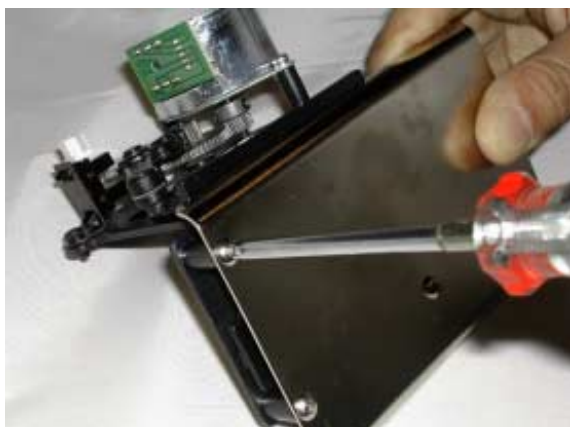

2. Exchange guide.

Fix the guide after moving it to the right.

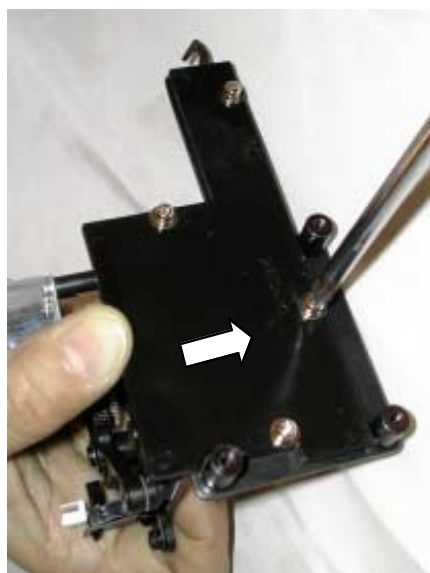

3. Install the guard plate.

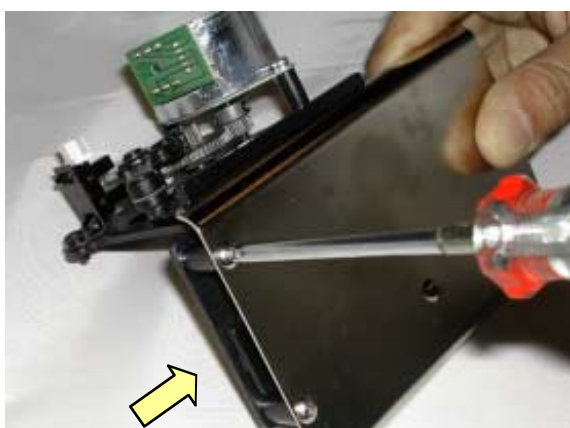

4. Please refer to [3-2-12 Fixing of thread catcher],  
install thread catcher to finish.

# Disassembling and Cleaning of jump solenoid

3-2-14

1. Disassemble the solenoid nut.

Use rubber sheet as safeguard.



2. Clean up the each part of the solenoid.



3. Put the designated grease on plunger part.

<Grease> [Shell Grease7 MIL-G-23827B CODE 70149](#)

Equivalent brand.



4. Assemble the solenoid to the original position.

The flat surface of the solenoid nut should come to the front.

Solenoid cable should come to the back side.

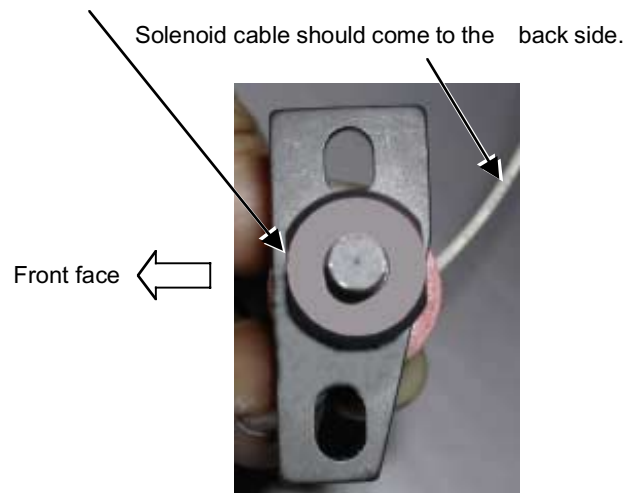

5. Confirm the movement of the plunger is smooth enough.

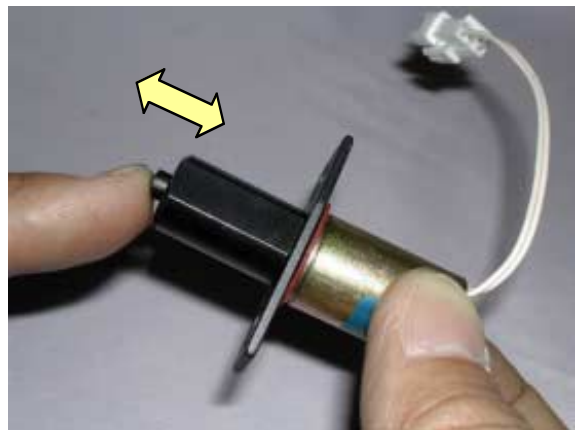

6. Procedure is done after assembling the Jump solenoid.

Referring to [3-2-7 Adjustment of fixing of jump solenoid].

## 3-3 Moving head

- 3-3-1 Assemble the moving head
- 3-3-2 Fixing of upper rail
- 3-3-3 Adjustment of backlash (back and forth) of moving head
- 3-3-4 Adjustment of needle position (back and forth)
- 3-3-5 Check of needle position
- 3-3-6 Adjustment of needle height
- 3-3-7 Exchange of needle bar, needle bar spring, cushion and pressure foot block
- 3-3-8 Fixing of needle bar boss guide plate
- 3-3-9 Exchange of take-up lever
- 3-3-10 Adjustment of thread holder
- 3-3-11 Exchange of magic-tape on thread holder
- 3-3-12 TC Thread detecting board position

# Assemble and remove moving head

3-3-1

1. Remove TC cover. (Fixing screw 6 pcs)



4. Remove thread guide plate B ass'y. (Fixing screw 2 pcs)



2. Remove TC cable and needle safety cable. (Option)



5. Remove front panel. (Fixing screw 2 pcs)



3. Plug off every cable from thread tension box.



# Assemble and remove moving head

3-3-1

6. Remove moving head. (Fixing screw 4 pcs)

<Caution> For back on moving head latter, please note needle number when you take off moving head.



7. Remove it by holding moving head up.

<Caution> Confirm that hook is apart from thread holder.



# Assemble and remove moving head

3-3-1

## 8. Install moving head tentatively.

<Caution> Please back on moving head to same needle position when you take off moving head.



<Caution> Two type of setscrews.

Please check length of screw

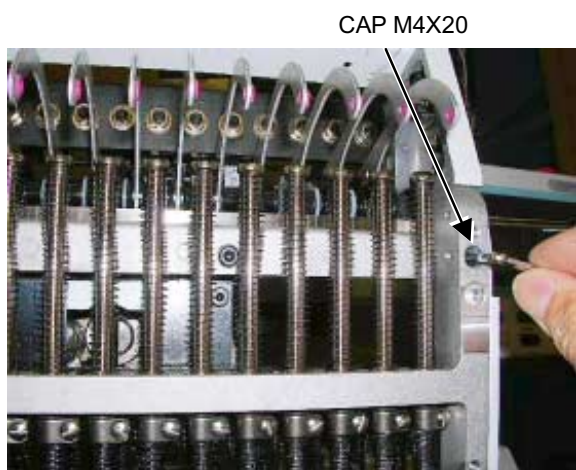

## 9. Please check NO gap between Moving head and Rail support .

You can check from side of moving head.

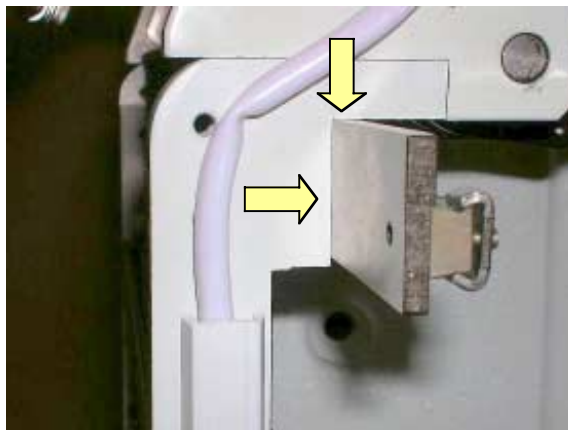

## 10. Check center (right and left)(back and forth) of needle and needle hole of needle plate.(Needle No.1 ,8 and 15.)

<Caution>

Should be check needle No.1 ,8 and 15.

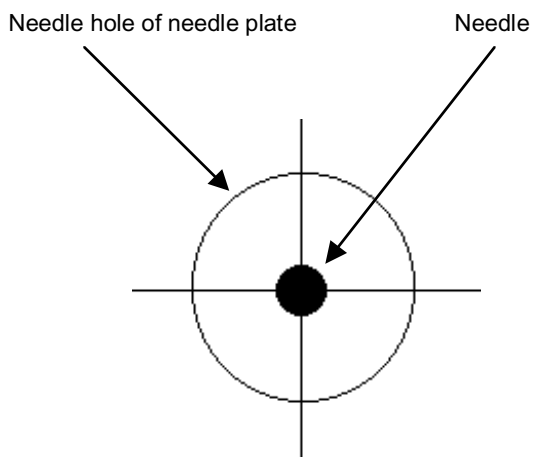

## 11. If not center (back and forth),please adjust needle position (back and forth).

Refer to [3-3-4 Adjustment of needle position (back and forth)].

## 12. If OK . Please check [needle position].

Refer to [3-3-5 Check of needle position].

## Fixing of upper rail

3-3-2

1. Slide Rail support on Upper rail ass y to center of fixed head and tight back screws.



<Caution>

Please push and close rail to following narrow direction then tight screws.

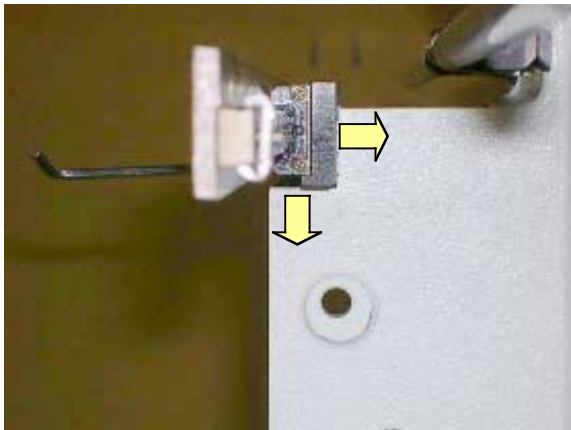

- 
2. Fixing has finished.

1. Adjust positioning roller shaft so as to put moving rail (lower) between bearings.

Move moving head back and forth so as not to cause backlash.



- 
2. After adjustment, check and adjust needle drop to finish  
Please refer to [3-3-4 Adjustment of needle position (back and forth)].

# Adjustment of needle position (back and forth)

3-3-4

1. Bring needle bar down.



Viewing from side, set to center of needle hole.

#Check and adjust with 1st, 8th and 15th needle.



2. Turn upper shaft and set needle near to the lowest needle position [L] to adjust positioning plate ass y.

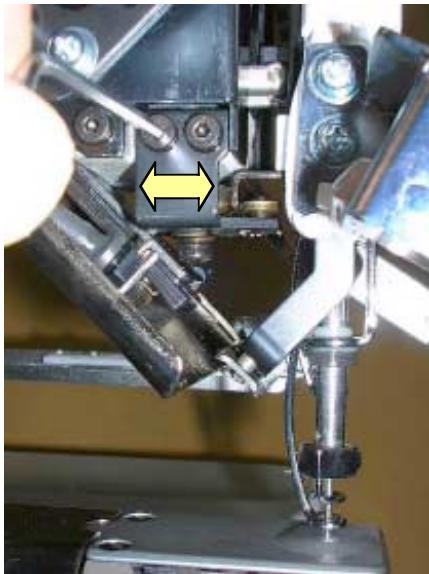

3. After adjustment, please be sure to check and adjust clearance between needle and shuttle hook.

Please refer to [3-5-1 Adjustment of rotary hook timing].

\* Insert Lower rail to between the two bearing deeply.  
(This is for setting of Moving head completely.)

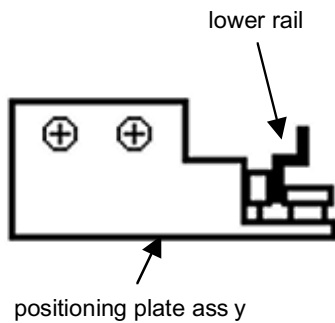

## Check of needle position

1. Slide moving head to 8<sup>th</sup> needle.

2. Stick a seal on needle hole of a needle plate.



3. Bring needle bar down.



4. Turn an upper axis up to [ 298 degrees —300 °], and it is the needle mark to a seal. A hole is made.

<Note>

Needle point will become large if the angle of a dial disc is made into 301 degrees or more.

An exact needle position check becomes impossible.



5. Reverse-rotate an upper axis, raise a needle bar, and unite with C [270 degrees].

(It returns to 300 degrees-> 230°, and unites with 270 degrees after that.)

<Note>

If a top axis is right-rotated, a needle will enter deeply, and needle hole is greatly.

It becomes. Therefore, an exact needle position check becomes impossible.

6. 1st needle and the 15th needles are to 298 degrees - 300 degrees about an upper axis by the above-mentioned procedure. It turns, a needle is lowered and a needle position is checked.

It will be O.K. if the needle point goes into the seal hole made by the 8th needles at this time.

7. Un-stick a seal on needle plate to finish.

# Adjustment of needle height

1. At this time, lower front panel. (Fixing screw 2 pcs)



2. Remove bobbin case.



3. Bring needle bar down.



5. Turn upper shaft to set dial disc to [ L + 5 degrees].



6. Loosen screw on needle bar boss.

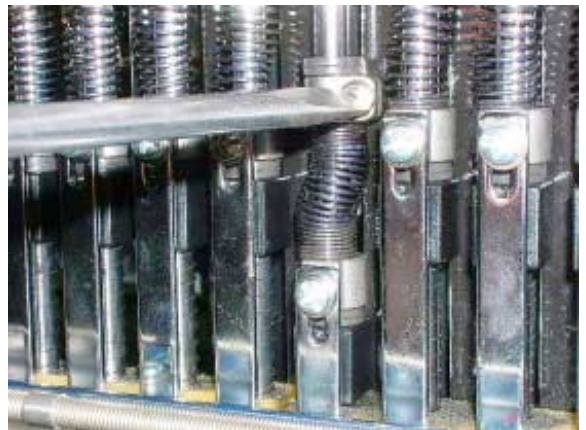

6. Put needle height gauge in rotary hook.



# Adjustment of needle height

7. Adjust the needle bar height up and down till the needle tip touches to the gauge slightly.



9. Tighten the screw of needle bar boss.



9. Set direction of needle stop as illustrated below.



10. Produce Needle height gauge from hook.

11. Back main shaft to [270 degree] position.

12. Set Lower front panel and bobbin case then end of process.

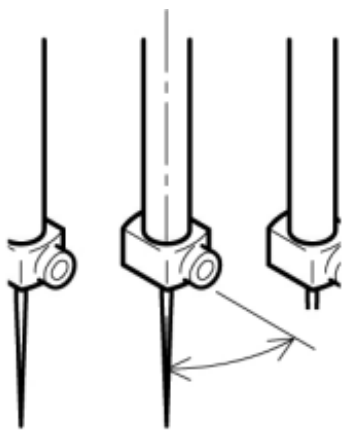

About 30 degrees

1. Referring to [3-2-11 Exchange of pressure foot], remove pressure foot.



2. Loosen screw on needle bar boss.

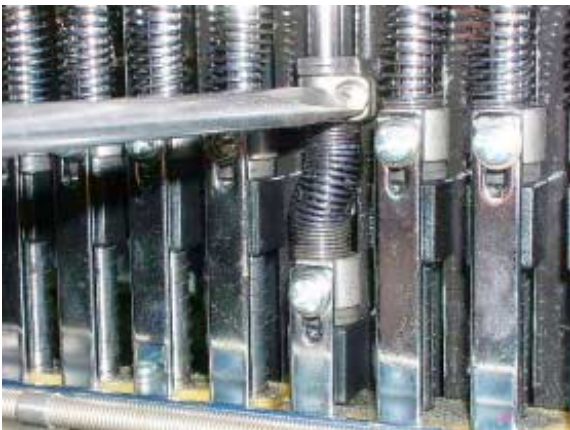

3. Take off Needle bar boss .



At this time, remove pressure foot spring (lower), pressure foot block, cushion, pressure foot boss and needle bar boss.

4. Set good parts to needle bar.

At this time, if insert extra needle bar from under, you can work more easily.

<Caution> Care to insert direction for Pressure foot and Pressure foot boss .

Pressure foot block

Check shape of direction.

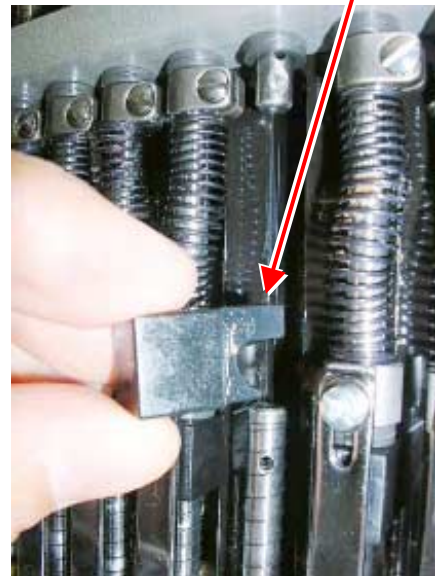

Pressure foot boss

Should hole to under side



5. Fix needle bar spring.

Finally, push upper needle bar and string all parts then pull out lower extra needle bar.



Slide needle bar to lower.



6. Fix pressure foot.



7. Fix needle, needle holder and cushion.



8. Adjust needle height.

Please refer to [3-3-6 Adjustment of needle height].

9. Adjust pressure foot height.

Please refer to [3-2-11 Exchange / Adjustment of pressure Foot].

10. Put removed parts back to finish.

# Fixing of needle bar boss check plate

3-3-8

1. Remove moving head.

Please refer to [3-2-1 Exchange of crank ass y].



2. Exchange of needle bar boss check plate.

3. Temporarily, use the pan head screw to center the needle bar boss check plate then fix the screw



4. Fix positioning needle bar boss check plate.



5. Put moving head and other removed parts back to finish.

# Exchange of take-up lever

3-3-9

1. Remove moving head.

Please refer to [3-3-1 Assemble and remove moving head].



2. Loosen screw on take-up lever shaft. (Fixing screw 2 pcs)

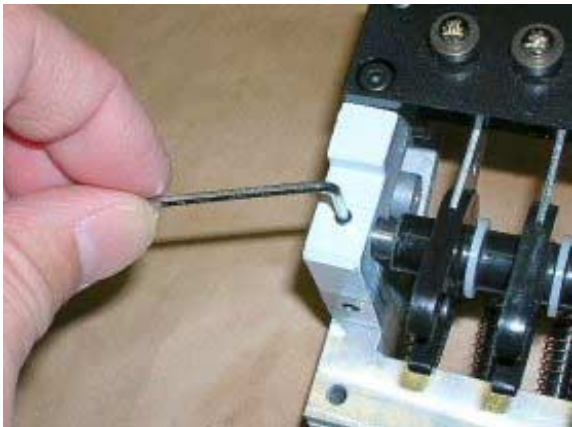

3. Remove the E-ring.



4. Please do not miss Plastic thrust washer between E-ring and Take up lever.

Remove plastic thrust washer. (1 pcs)

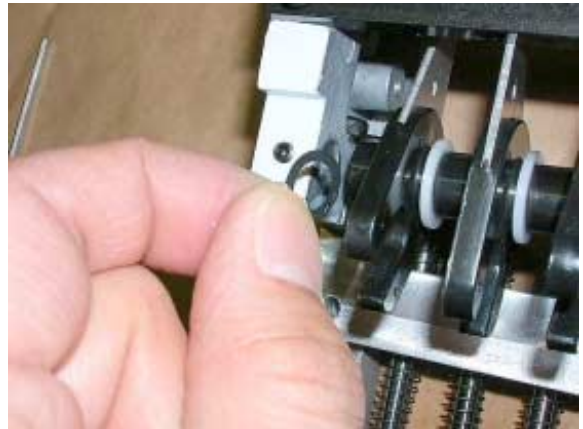

5. Remove the take up lever shaft first then remove the take-up lever.

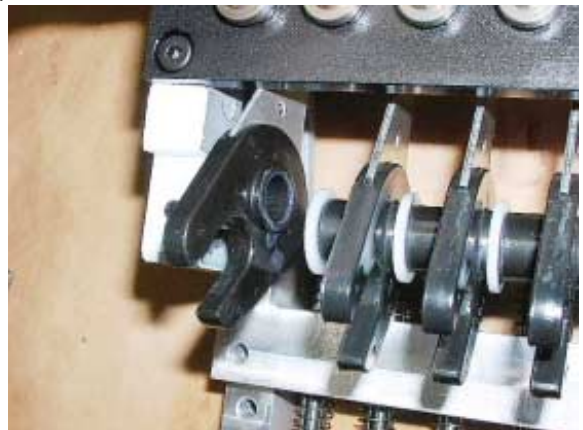

6. Remove plastic washer.



# Exchange of take-up lever

3-3-9

7. Install good take-up lever assembly.

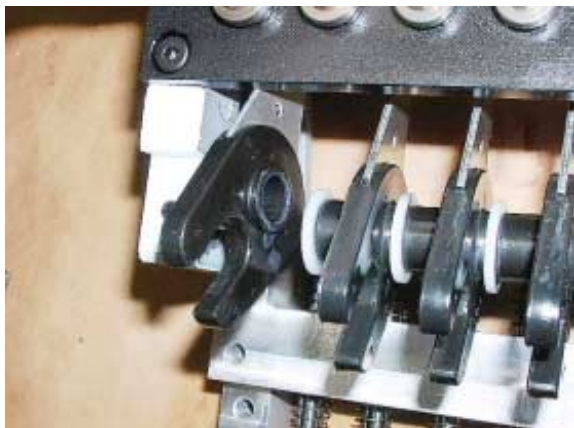

8. Leave space of [0.2mm] between take-up lever and moving head .

Tight screw for Take up lever shaft



9. Put moving head in previous position to finish.

# Adjustment of thread holder

1. Loosen screw to the extent that thread holder moves.

(Fixing screw 4 pcs)



2. Please put out and withdraw thread catcher by your finger and fix holder position at smoothly moving position.

<Caution> Please check smoothly moving at 1<sup>st</sup> and 12<sup>th</sup> needle.



Positional relationship between hook and holder (lower)  
When downing the needle, should have gap more than 1 mm between catch hook and presser foot.

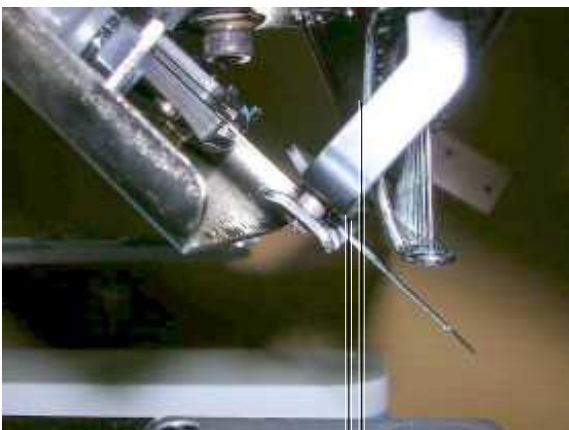

→ ← More than 1 mm

4. Thread catcher device should be adjusted if above clearance is not keepable.

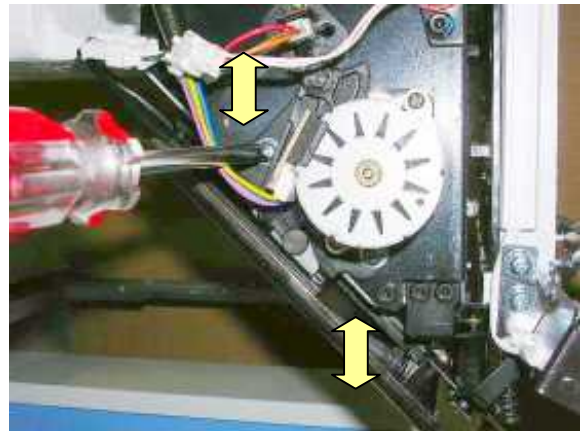

5. Press thread trim key and confirm whole thread trim revolution.

# Exchange of majic-tape on thread holder

3-3-11

1. Remove thread holder ass'y. (Fixing screw 4 pcs)



4. Assemble holder (lower).



2. Remove holder (lower). (Fixing screw, nut 2 pcs)



5. Install holder ass'y to moving head in reverse order to finish.

Please refer to [3-3-10 Adjustment of thread holder].

3. Exchange the majic-tape.

<Caution> Please check screw hole right and left side.

Also set point line magic-tape and holder bracket.



**<Note>**

(Please disconnect machine inlet from the wall)

1. Remove cover by following 6 set screws.

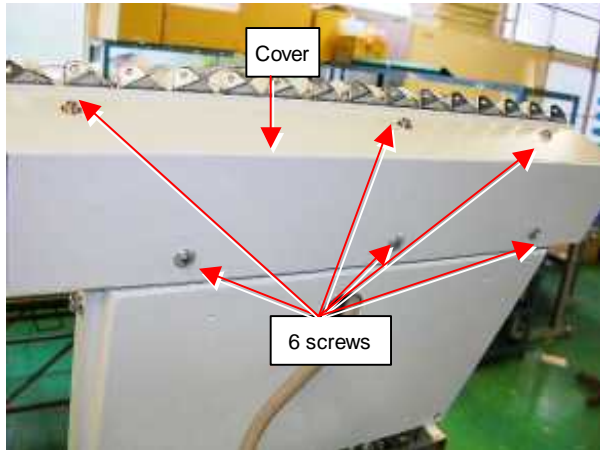

2. TC15 board consists of 2pcs.

Remove 2 screws as showed bellow and take out TC cord, TC connecting cord and one TC15 Board (Follow the same steps to take out Another TC Board)

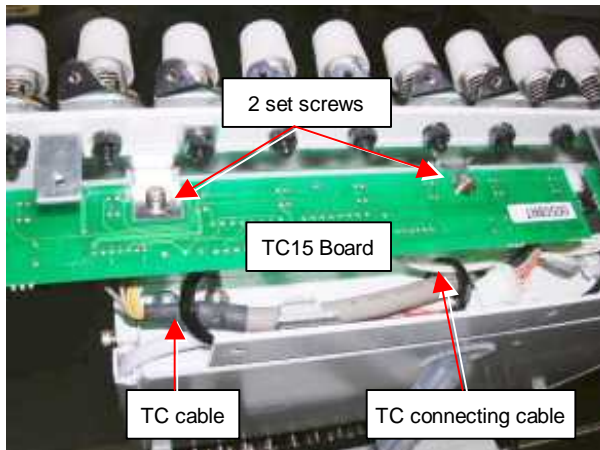

3. Put back TC15 Board. Set the cords of Step 2 and temporarily tighten 2 screws as showed bellow.

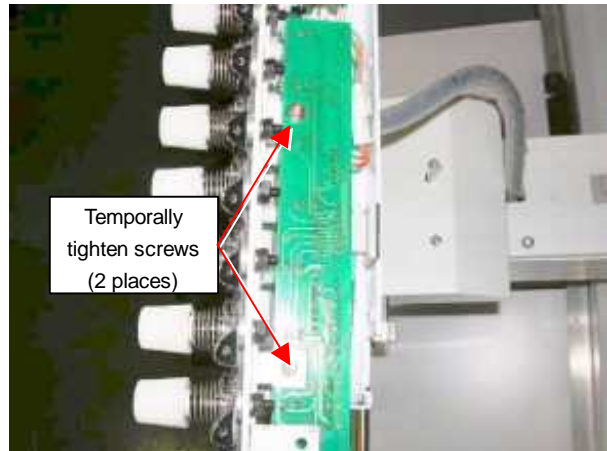

4. Slide TC15 circuit board for slit position to center of the sensor

**<NOTE>**

Check the position of the board according to the sensor position.

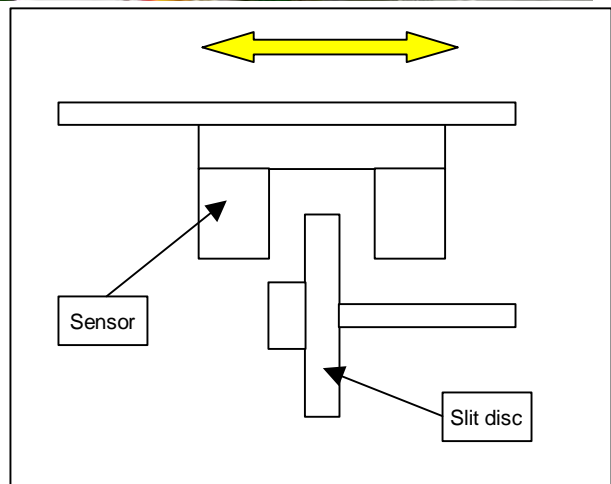
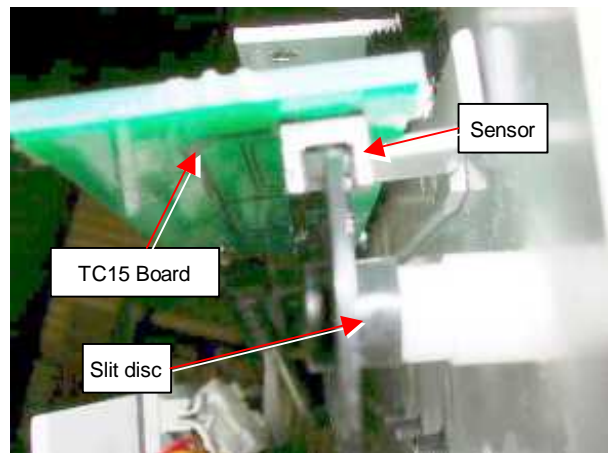

5. Return the cover.

\* Finish of this chapter.

## 3-4 Needle bar change unit

3-4-1 Fixing of needle bar change unit

3-4-2 How to take out needle bar change stop position sensor and needle position sensor (potentiometer)

3-4-3 Adjustment of needle bar change stop position sensor and needle position sensor (potentiometer)

1. Place needle bar change unit assembly.  
please set positioning hole on unit assembly to positioning pin.

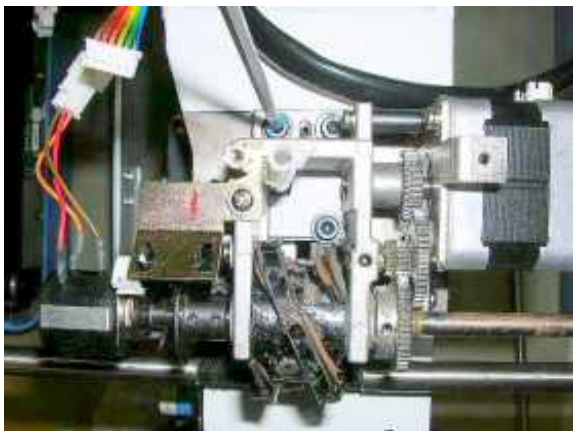

- 
2. Bring needle down, turn upper shaft to set near to [L point].



3. Adjust position of unit assembly so that needle comes to center against needle hole on needle plate and fix screws.



- 
4. Install parts in reverse order to finish.  
For adjustment of fixing of each unit, please refer to process to adjust fixing of each unit.

# How to take out needle bar change stop position sensor and needle position sensor (potentiometer)

3-4-2

## <Note>

Disconnect the plug during the work.

1. Move the head to 15<sup>th</sup> needle by turning a knob by hand.

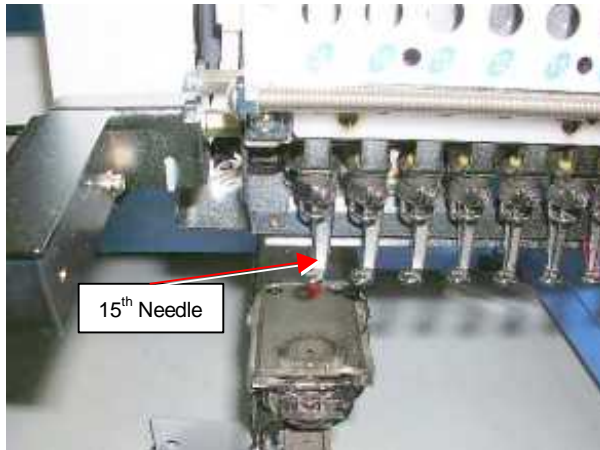

2. Take out cover for needle bar change unit.

Remove the bellow mounting screws (2 places) and take out cover for needle bar change unit.

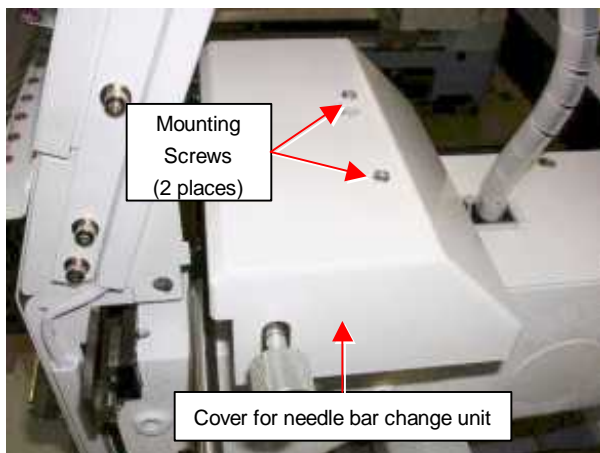

3. Remove connectors for cables of Needle bar selection (2 places) showed as showed bellow.

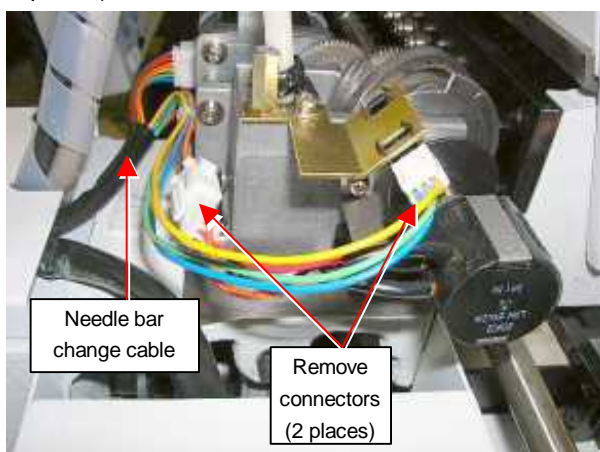

4. Mounting screw and stud a as showed bellow and take out sensor board

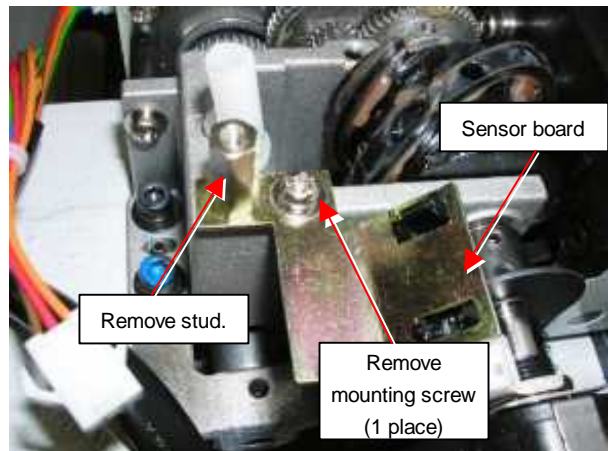

5. Take out potentiometer.

Remove mounting screws (2 places) as showed bellow.

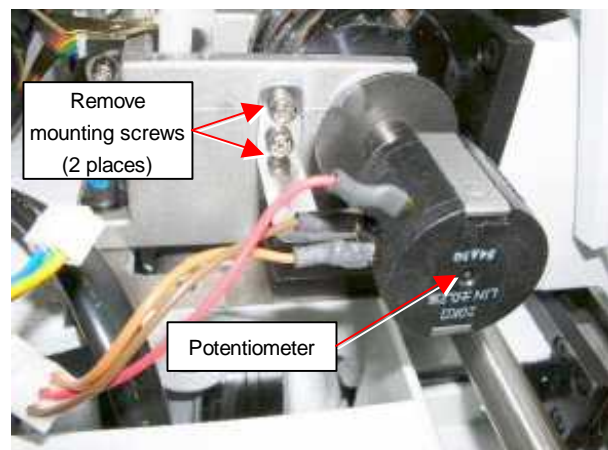

6. Loosen a mounting screw as showed bellow.

Potentiometer can be taken out by pulling to the arrow direction.

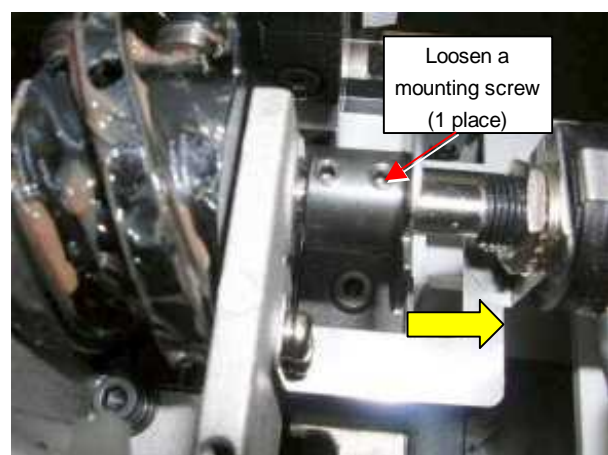

Finish of procedures

# Adjustment of needle bar change stop position sensor and needle position sensor (potentiometer)

3-4-3

1. Put a sensor board as the bellow picture shows.

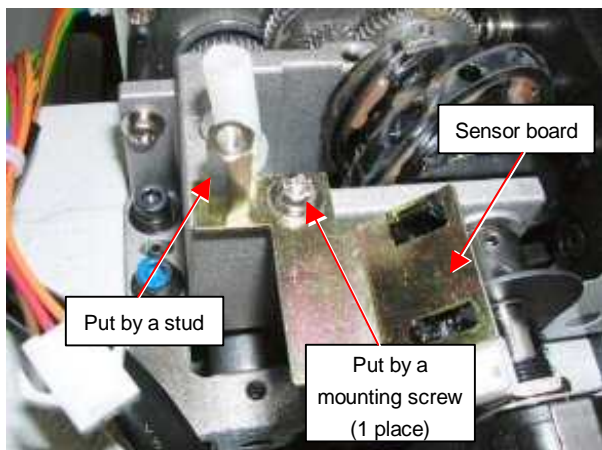

2. Loosen a mounting screw of slit, so that the slit can rotate separately.

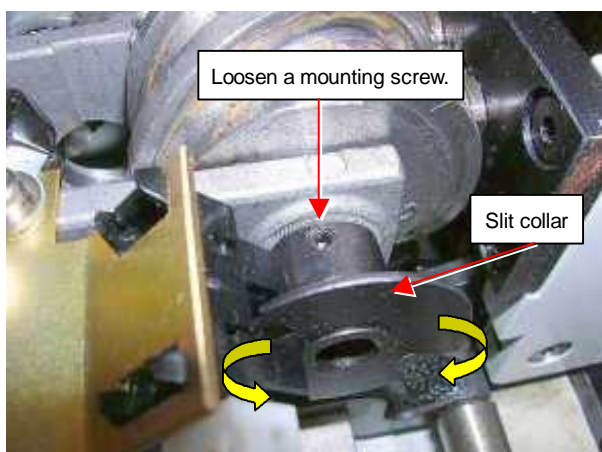

3. Set position where sensor on sensor board and slit do not cross to area where moving head does not move when turning groove cam.

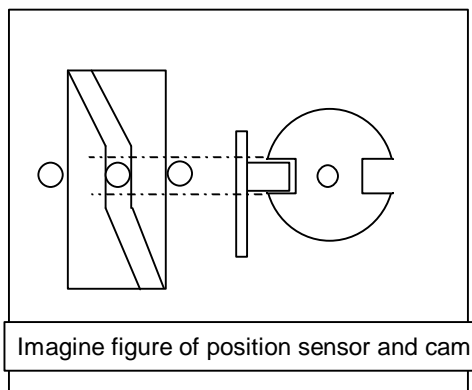
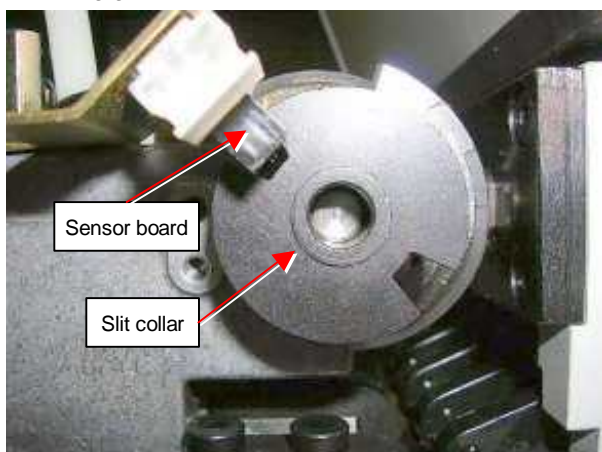

4. Put potentiometer.

Insert needle bar change cord to the connector from potentiometer.

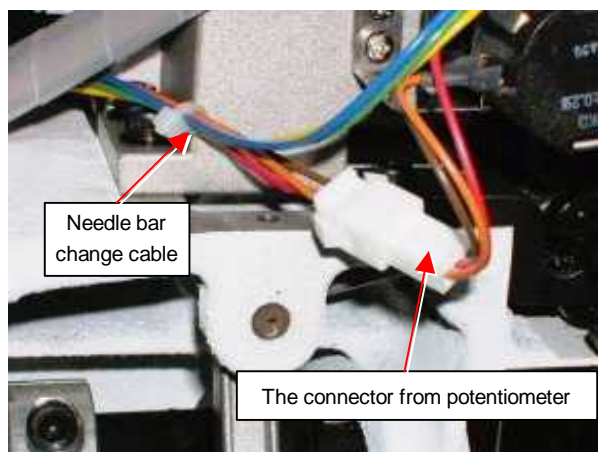

5. Enter maintenance mode, referring to [ 9-1 How to enter maintenance mode ]

6. Move a cursor by  to [Machine] and **SET** button.

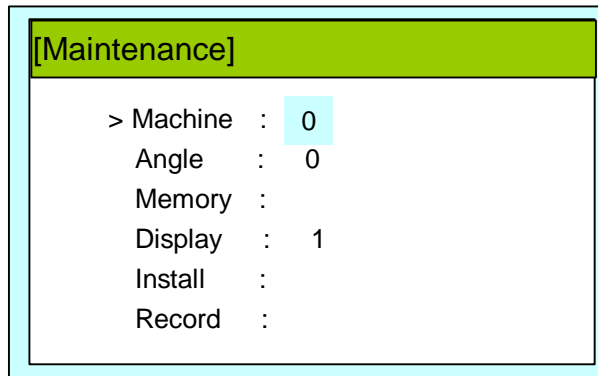

# Adjustment of needle bar change stop position sensor and needle position sensor (potentiometer)

3-4-3

7. Input [Machine : 31] by  and **SET** button.

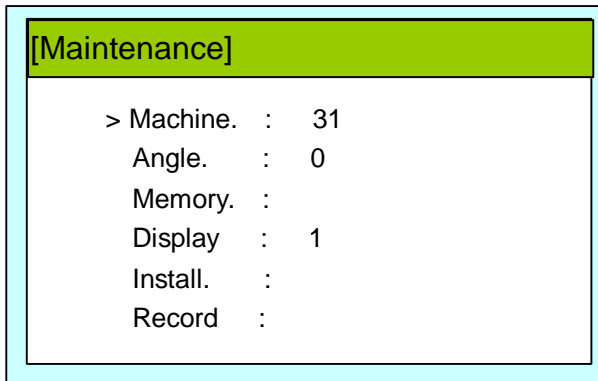

8. Turn the axis of potentiometer, so that the display of control box shows as bellow.

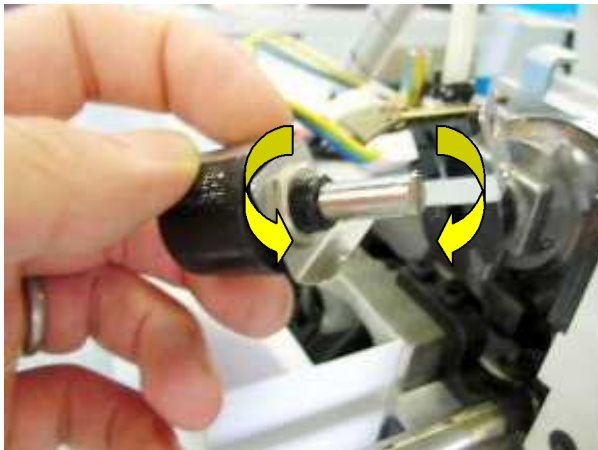

[Display of control box]

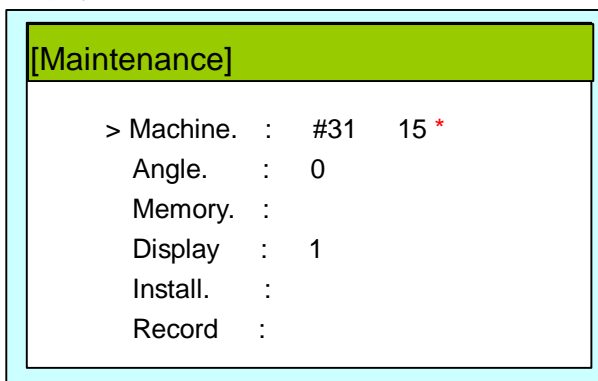

<Note>

[ Machine : # 31 15 \* ]

Adjust potentiometer to show “ \* ” mark. Buzzer also sounds at the position.

9. Put potentiometer keeping the position of step 8.

Put potentiometer following as the bellow picture.

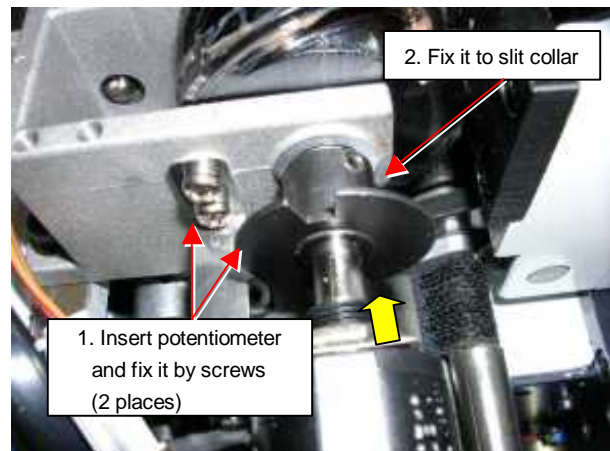

<Check>

[ Machine : # 31 15 \* ]

\* Make sure that “ \* ” shows up when the center of sensor of sensor board is almost center of slit.

\* If the position is not collect. take out the potentiometer and adjust it again.

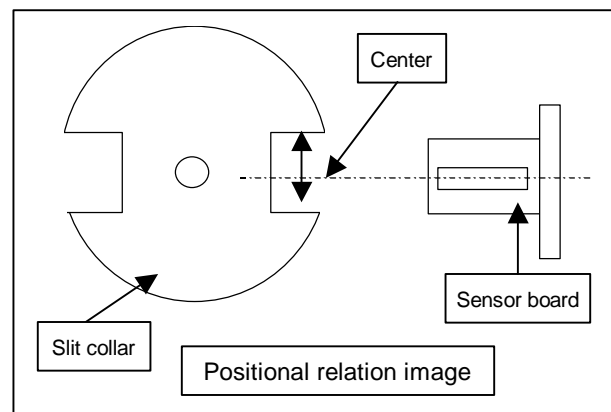

7. Turn the knob of needle bar change and check the position of 1<sup>st</sup> needle.

<Check>

[ Machine : # 31 1 \* ]

Make sure that the display shows “ \* ”, where the sensor indicate around the center of the slit of the plate. Otherwise, take out the potentiometer and adjust it.

End of process.

## 3-5 Rotary hook

3-5-1 Adjustment of rotary hook timing

3-5-2 Adjustment of retainer on rotary hook

# Adjustment of rotary hook timing

3-5-1

1. Remove needle plate. (Fixing screw 2 pcs)



2. Tighten screw on rotary hook. (3 pcs)



3. Bring needle down.



4. Turn upper shaft and set dial disc to [25 degrees].



5. Adjust rotary hook timing.

This procedure is preconditioned to use needle type [DB-K5] in which contains with our standard accessory.

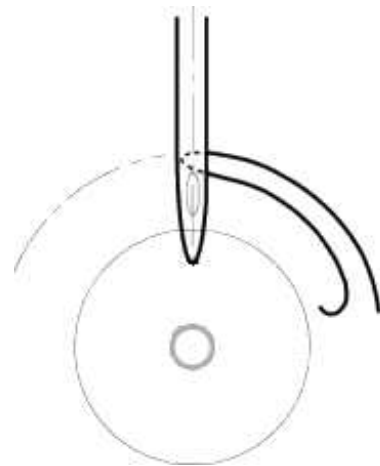

# Adjustment of rotary hook timing

At this moment, clearance between needle and rotary hook should be [0.1-0.15mm].

Check and adjust with 1st, 8th and 15th needle.

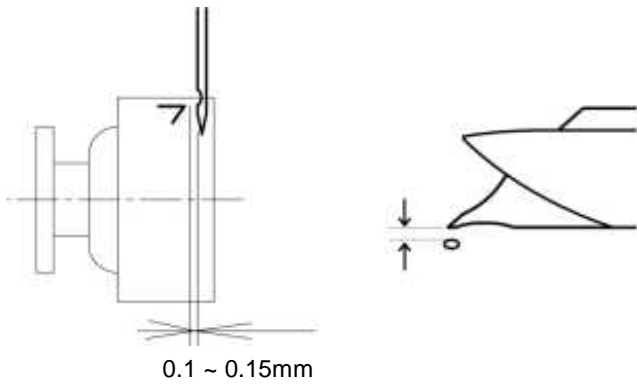

6. For making sure, check position of retainer on bobbin case holder.

Please refer to [3-5-2 Adjustment of retainer on rotary hook] for adjusting value and follow it.



8. Adjustment has finished.

# Adjustment of retainer on rotary hook

1. Loosen screw to the extent that retainer on bobbin case holder moves. ( 1 pcs)



2. Adjust position back and forth, left and right.  
Space has to be [0.8mm] and the position right and left is center of the needle.

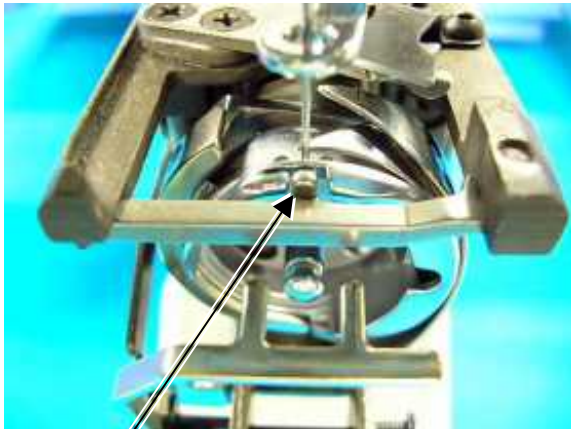

Needle center and retainer center should come to same position.

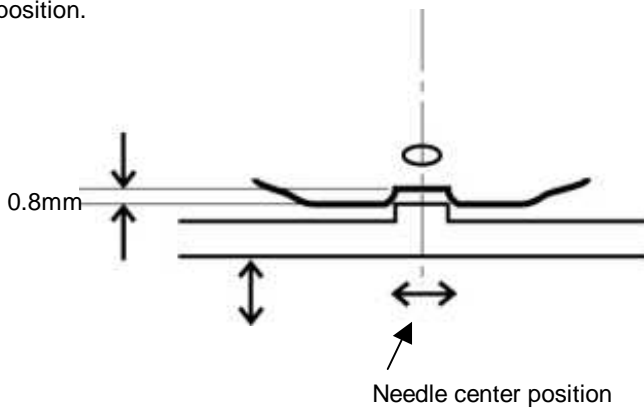

4. Adjustment has finished.

## 3-6 Thread cut unit

- 3-6-1 Adjust for thread trim sensor and stopper
- 3-6-2 Exchange of moving knife
- 3-6-3 Exchange of fixed knife
- 3-6-4 Adjustment of moving knife and fixed knife
- 3-6-5 Adjustment of position of moving knife
- 3-6-6 Adjustment of bobbin thread holder
- 3-6-7 Exchange of keeper solenoid
- 3-6-8 Adjustment of position of keeper

# Adjust for Thread trim sensor and stopper

3-6-1

## <Note>

Please disconnect power inlet from the wall.

1. Remove the needle plate.

(Remove two setscrews as following picture)

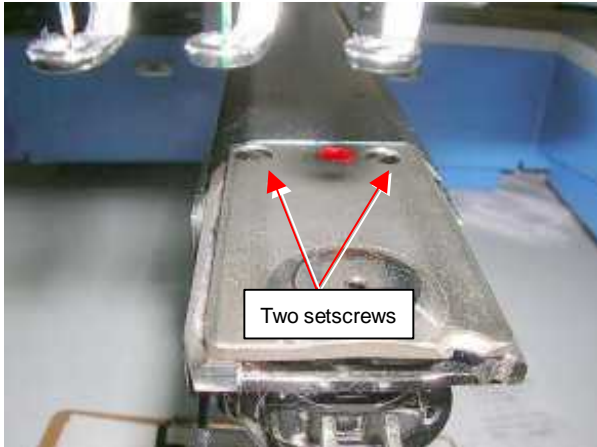

2. Take off Cover G ass'y

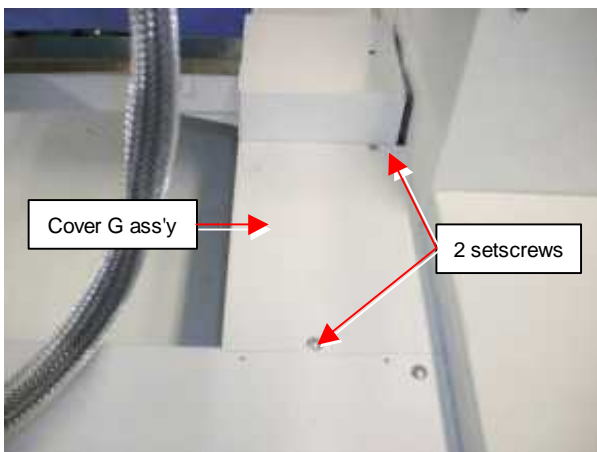
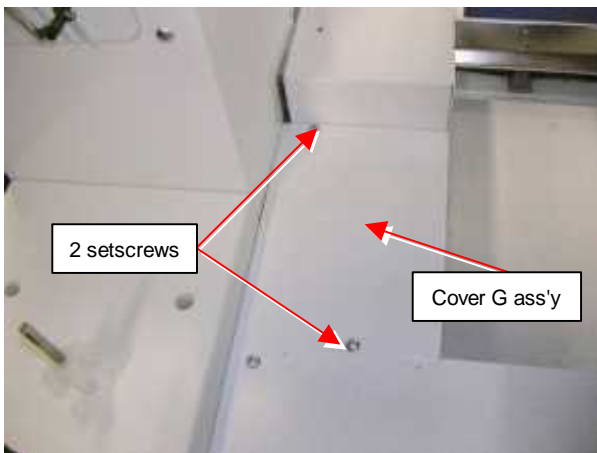

3. Open Maintenance mode

Reference [9-1 How to enter Maintenance mode]

4. Select [ Machine : 51 ] by  button and press **SET** button.

### [Maintenance]

```
> Machine. : # 51
  Angle.   : 0
  Memory.  :
  Display  : 1
  Install. :
  Record   :
```

5. Press  button and moving knife for knife closing position same as following drawing.

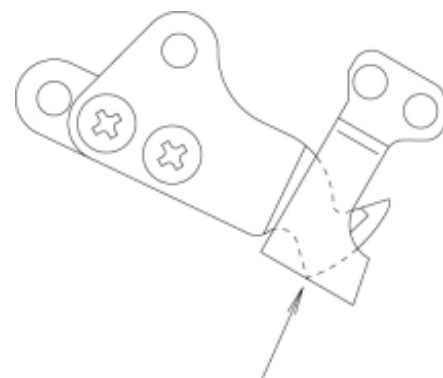

[Detail Moving knife closing position]

Same face "Fixed knife" cutting face and "Moving knife" point.

6. Loose Setscrew for adjusting knife sensor position.  
Slide Knife sensor to narrow direction. and fix sensor position when you have beeper sound.

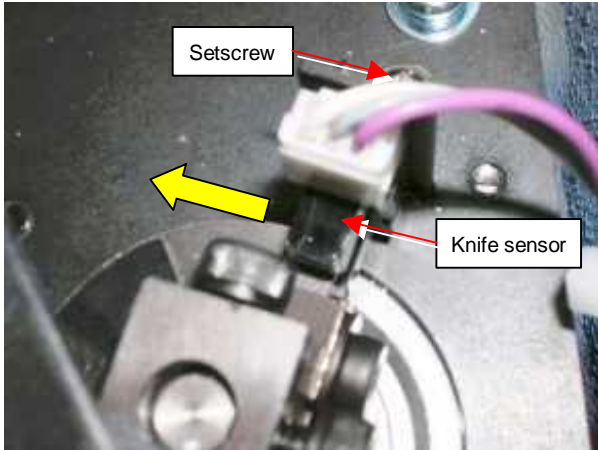

<Note>

Please fix Sensor position to parallel position with Detecting plate

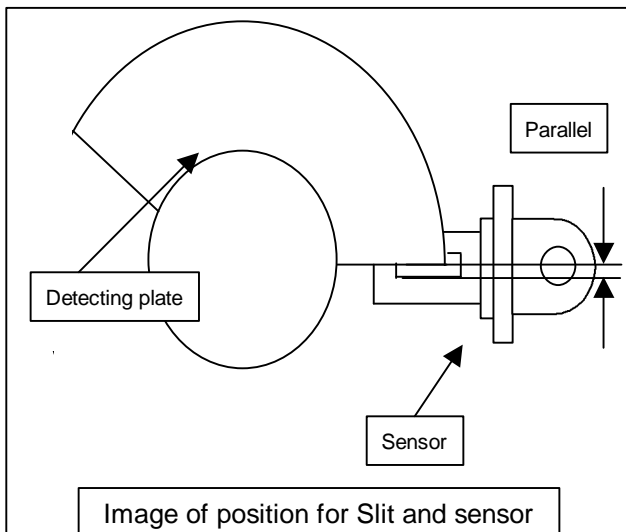

7. Adjust stopper position.  
Press **ESC** key. Move knife automatically.

8. Loose stopper screw and adjust clearance 1mm as following picture.

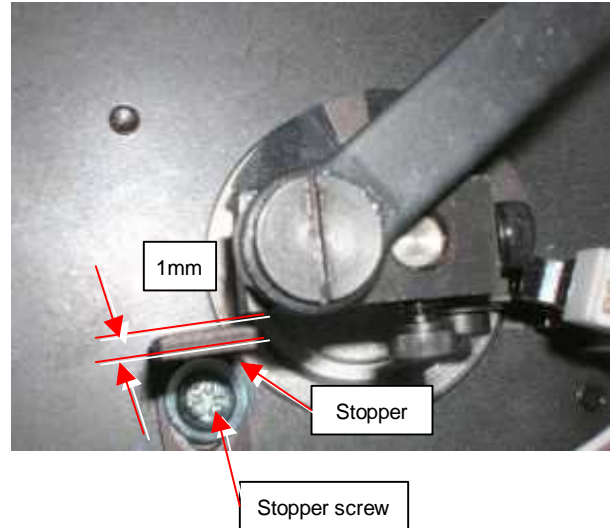

End of process.

# Exchange of moving knife

3-6-2

1. Remove needle plate.



2. Remove knife drive shaft retainer.



3. Pull out knife drive shaft ass'y.



4. Exchange moving knife.



5. Setting drive link hole to moving knife, insert knife drive shaft assembly.



6. Pushing down moving knife and knife drive shaft retainer like putting them together, fix knife drive shaft retainer.

# Fix so that there is no backlash in upward and downward direction.



7. Referring to [3-6-4 Adjustment of moving knife and fixed knife], check how well thread is cut and adjust, then finish this process.

## Exchange of fixed knife

1. Remove needle plate.



2. Remove fixed knife.



3. Exchange fixed knife.



4. Tighten fixed knife pushing to forward as full as possible.



### <Caution>

In case moving knife and the left side of fixed knife overlaps excessively when closing, adjust the position of fixed knife slightly to the right direction.

5. Referring to [3-6-4 Adjustment of moving knife and fixed knife], check how well thread is cut and adjust, then finish this process.

1. Remove needle plate



2. Check if knife drive shaft has no backlash in up and down direction.

If backlash is found, adjust it referring to [3-6-2 Exchange of moving knife].



4. Cut thread and check how well it is cut.

Use two polyester threads for checking.



3. Adjust slant of fixed knife with [upper adjustment screw] and [lower adjustment screw] that fix fixed knife.

<Note> Rub these screws together to the extent that you don't feel resistance.



5. Check several times and if no mistakes are found, finish this process.

# Adjustment of position of moving knife

3-6-5

1. Loosen screw on link pin. (Fixing screw 1 pcs)



2. Open "Moving knife" maximum position by finger.



3. In this condition, Turn link pin till moving knife minimum opened point and fix link pin.



4. At this moment, please check feel "link rod ass'y" little bits play up and down (0.2mm).

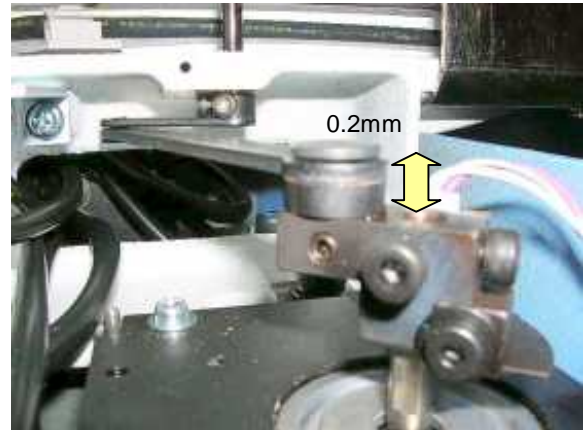

If you had not feel of play, please loose screw on "Drive lever" and slide up or down for make small play of "link rod ass'y"

<Caution> Motor shaft has flat face for setscrew.



Drive lever

# Adjustment of bobbin thread holder

3-6-6

1. Remove needle plate. (Fixing screw 2 pcs)



2. Close moving knife like putting bobbin thread between moving knife and bobbin thread holder.



3. Adjust height of bobbin thread holder with adjusting screw.

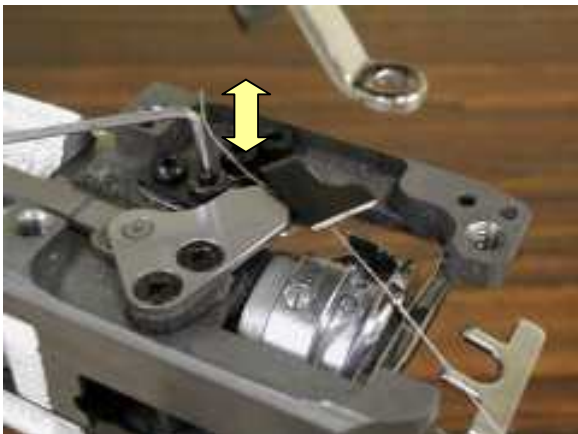

4. Pull bobbin thread toward arrow mark and see that bobbin thread comes off with tensile gauge [20-25g].



5. Tighten lock nut. (Don't move adjusting screw.)



6. Check several times and if OK, finish this process.

# Adjustment of bobbin thread holder

3-6-6

1. Remove needle plate. (Fixing screw 2 pcs)



2. Close moving knife like putting bobbin thread between moving knife and bobbin thread holder.



3. Adjust height of bobbin thread holder with adjusting screw.

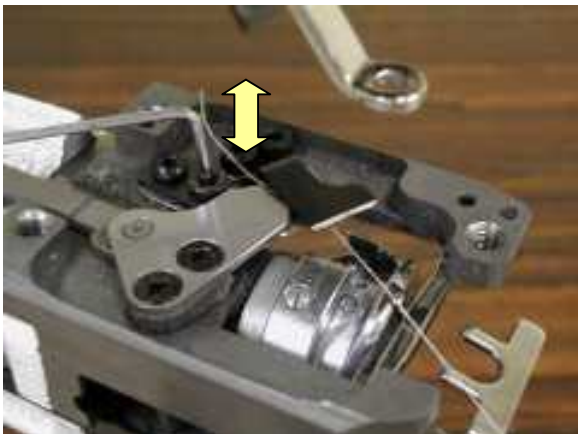

4. Pull bobbin thread toward arrow mark and see that bobbin thread comes off with tensile gauge [20-25g].



5. Tighten lock nut. (Don't move adjusting screw.)



6. Check several times and if OK, finish this process.

# Exchange of keeper solenoid

6. Install good parts.

**<Caution>**

Pushing keeper solenoid to solenoid base.

Insert 2.0mm thickness gauge between solenoid base to polyslider.

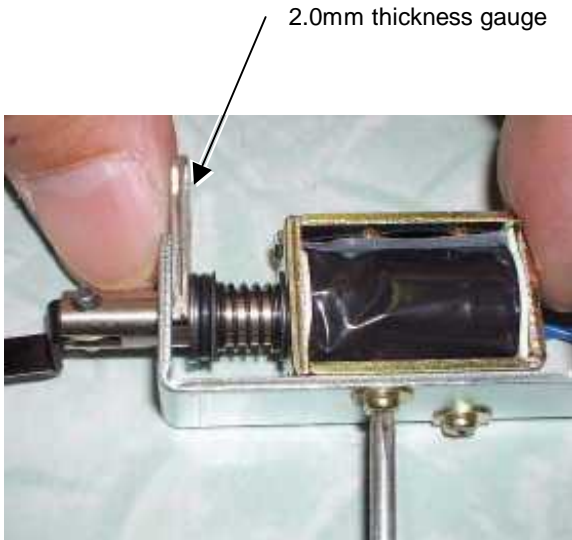

<Front view>

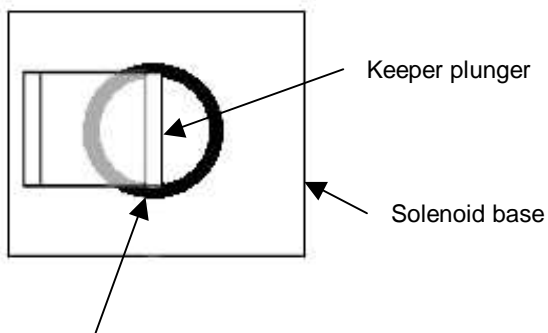

Clearance between keeper plunger and solenoid base should be kept as much as equally.

7. Put keeper solenoid ass'y in previous position then adjustment of position of keeper to finished.

Referring to [3-6-8 Adjustment of position of keeper].

# Adjustment of position of keeper

3-6-8

1. Loosen screw on solenoid base. (Fixing screw 2 pcs)



3. Insert keeper positioning gauge (Bobbin) into rotary hook.



<View from right>

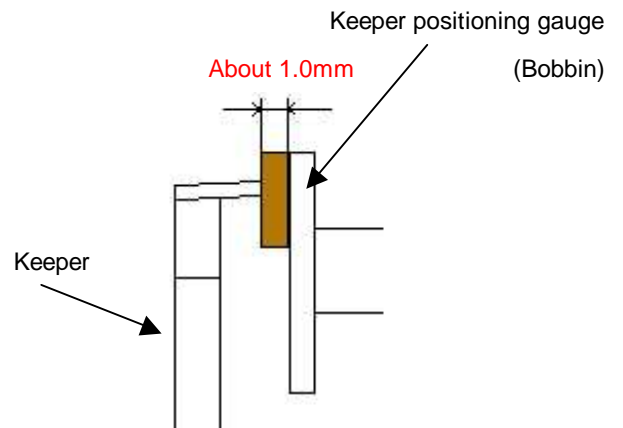

4. Adjust position of stopper.

This is the position where tip of keeper contacts to gauge



3. Adjust solenoid base where tip of keeper contacts slightly to the gauge then tighten bracket screw. Clearance between bobbin and keeper is [about 0.8mm].



5. Adjustment has finished.

## 3-7 Carriage unit

3-7-1 Adjustment of X carriage belt tension

3-7-2 Exchange of X carriage belt

3-7-3 Adjustment of Y carriage belt tension

3-7-4 Exchange of Y carriage belt

3-7-5 X carriage limit sensor replacement and adjustment

3-7-6 Y carriage limit sensor replacement and adjustment

# Adjustment of X carriage belt tension

3-7-1

1. Remove frame base. (Fixing screw 2 pcs)



2. Remove base cover. (Fixing screw 6 pcs)



3. Loosen fixing screw for tension pulley bracket slightly.

(Fixing screw 2 pcs)



Loosed the adjusting nut.

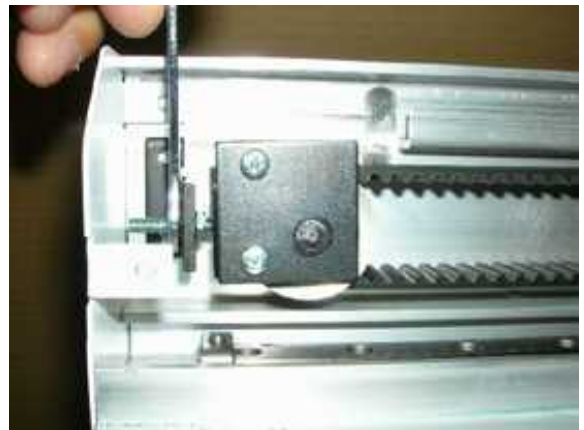

4. Adjust belt tension.

Use push and pull gauge.

<Caution> Scaling position should center between two position sensor boards.



# Adjustment of X carriage belt tension

3-7-1

5. When push belt by tension gage 1.5kg should width between belts 12mm.

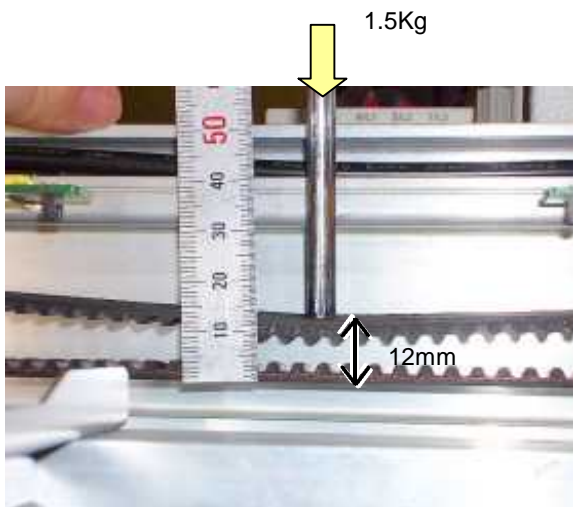

6. Adjustment, tighten fixing screw for tension pulley bracket

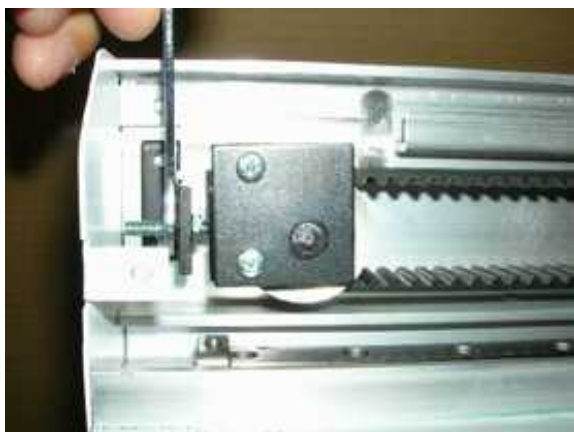

7. Fix tension pulley bracket.



8. Finally check belt tension then tight lock nut.



9. Return things back to previous places in reverse order.

10. Please refer to [9-6 Position—Registration of coordinates for positioning sensor], registry embroidery area and finish this adjustment.

# Exchange of X carriage belt

3-7-2

1. Remove frame base. (Fixing screw 2 pcs)



2. Remove base cover. (Fixing screw 6 pcs)



3. Remove detecting plate. (Fixing screw 2 pcs)

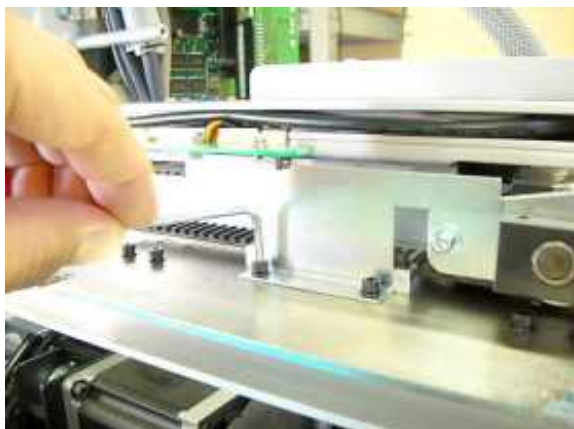

4. Loosen fixing screw for tension pulley bracket slightly.

(Fixing screw 2 pcs)



5. Loosed the adjusting nut.



6. Remove belt holding plate. (Fixing screw 4 pcs)



# Exchange of X carriage belt

3-7-2

7. Exchange belt to good one.



<Caution> Please do not fit tooth of belt to inside ditch.

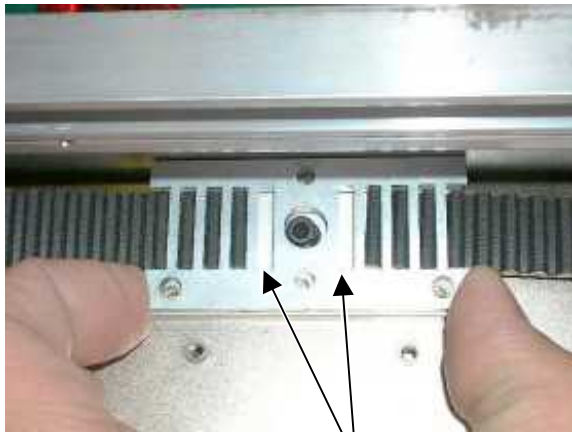

Inside ditch

8. Install Belt holding plate.



9. Referring to [3-7-1 Adjustment of X carriage belt tension], adjust tension of belt.

10. Return case cover and frame base to previous places.

<Caution> When set "Detecting plate", please tight screw at insert plate to sensor ditch.



11. Please refer to [9-6 Position—Registration of coordinates for positioning sensor], registry embroidery area and finish this adjustment.

# Adjustment of Y carriage belt tension

3-7-3

1. Referring to [2-2 Removal of outer covers], remove cover E and cover F.



Showing from above



3. Loosen tension screw so as to move tension.



2. Loosen lock nut for tension adjustment screw.



4. Move stay to rear end.

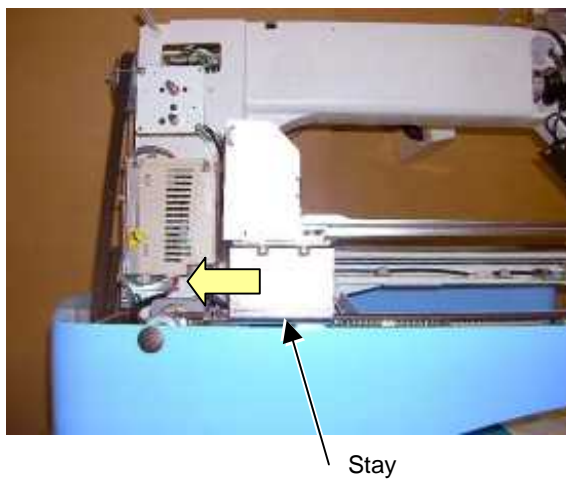

# Adjustment of Y carriage belt tension

3-7-3

5. Measure belt tension at between screw hole 9<sup>th</sup> and 10<sup>th</sup>.

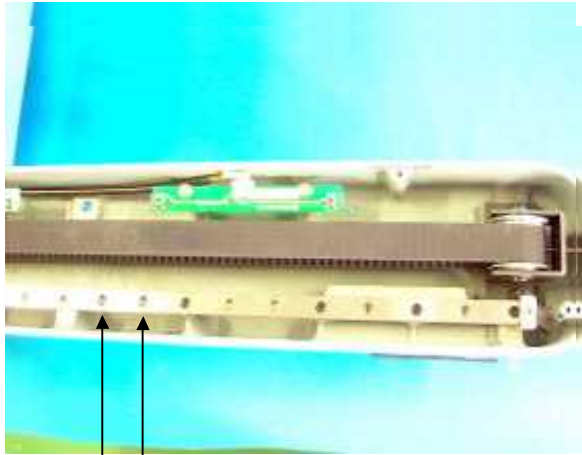

10 9

Measurement point

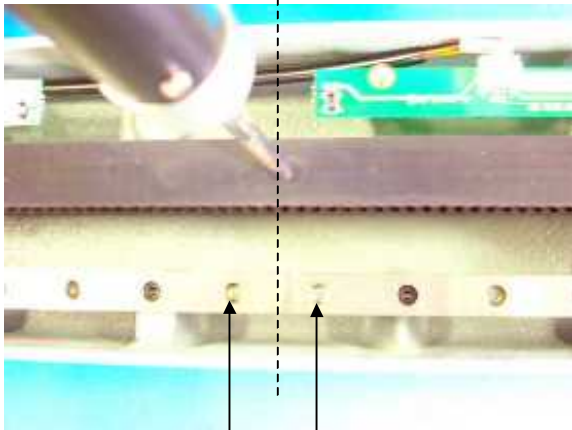

10 9

6. Place some straight bar on arm of Y carriage.

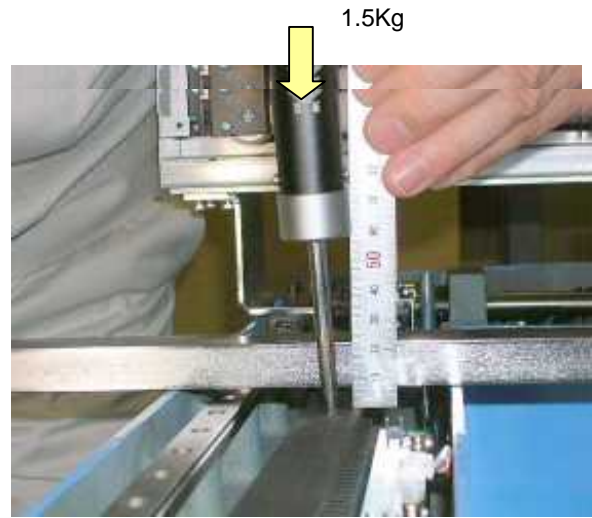

When press belt 1.5kg, should [7mm] space between straight bar and face of belt.

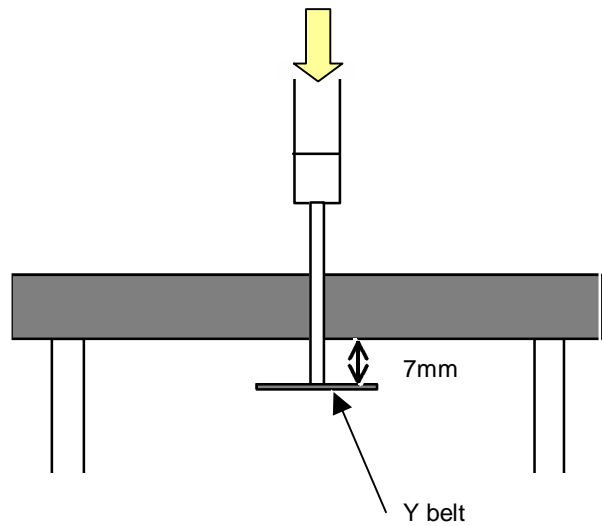

7. Adjust with screw on Idler bracket Y.



8. Fix Idler bracket Y.



9. Check belt tension again then tighten lock nut.



Similarly, adjust Y carriage right also.

10. Put things back in reverse order of respective adjustment.

11. Please refer to [9-6 Position—Registration of coordinates for positioning sensor], registry embroidery aria and finish this adjustment.

# Exchange of Y carriage belt

3-7-4

1. Referring to [2-2 Removal of outer covers], remove cover E and cover F.



Showing from top.



2. Loosen lock nut for tension adjustment screw.

3. Loosen tension screw so as to move tension.

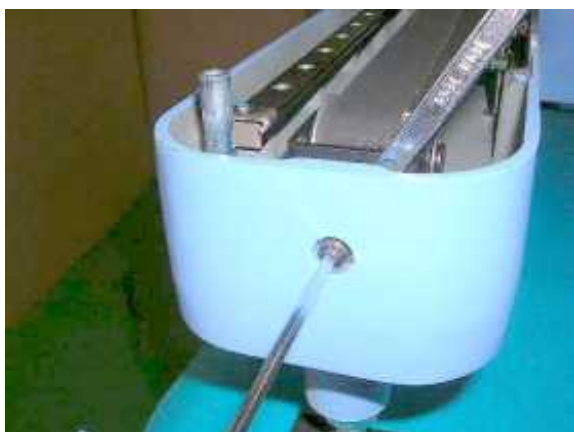

4. Remove belt holding plate. (Fixing screw 2 pcs)

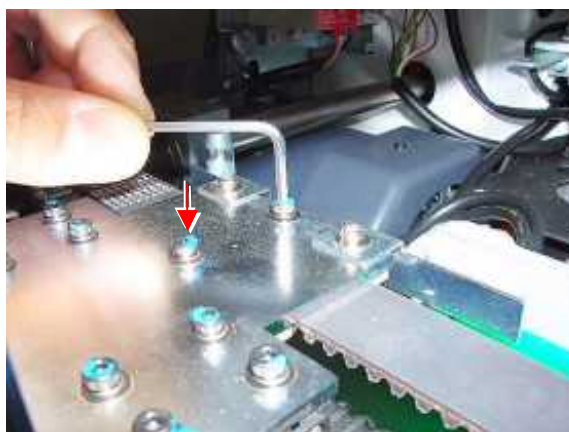

# Exchange of Y carriage belt

3-7-4

5. Loosen screw on drive pulley. (Fixing screw 2 pcs)



6. Exchange belt.

7. Connect belt at center of belt holding plate.

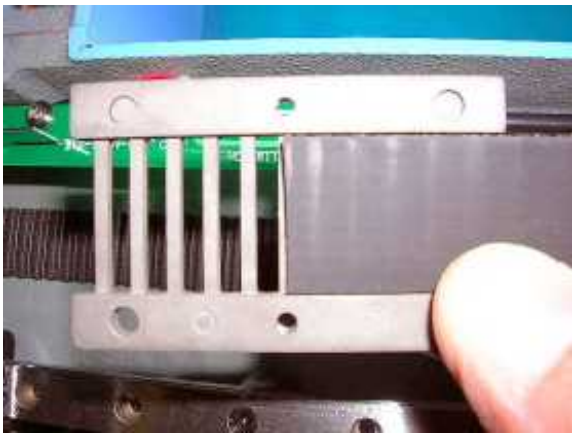

Insert "holding plate" with "belt" to under the "carriage stay" till setting screw hole come from rear side of stay.



Then set rear side belt to "holding plate."

And slide back "holding plate" till setscrew position.



8. Fix belt holding plate.

<Caution> Please care belt dose not out from "belt holding plate".

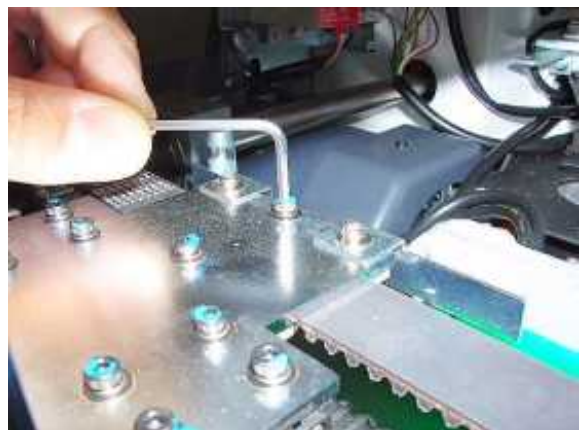

# Exchange of Y carriage belt

3-7-4

9. Referring to [3-7-3 Adjustment of Y carriage belt tension], adjust tension of Y belt.

10. Loosen fixing screw for X carriage ass'y.

(Fixing screw 4 pcs)



11. Insert positioning pin gauge 6mm.



Insert positioning pin gauge to two holes.



12. Touch X carriage body to pin gauges.



Should not have gap between pin and carriage.

13. Tighten fixing screw for X carriage ass'y.



14. Check no gap between pin and carriage then fix screw of drive pulley.



15. Return cover to previous places.

16. Please refer to [9-6 Position—Registration of coordinates for positioning sensor], registry embroidery area and finish this adjustment.

**<Note>**

Please turn off machine power.

1. Remove X carriage cover.

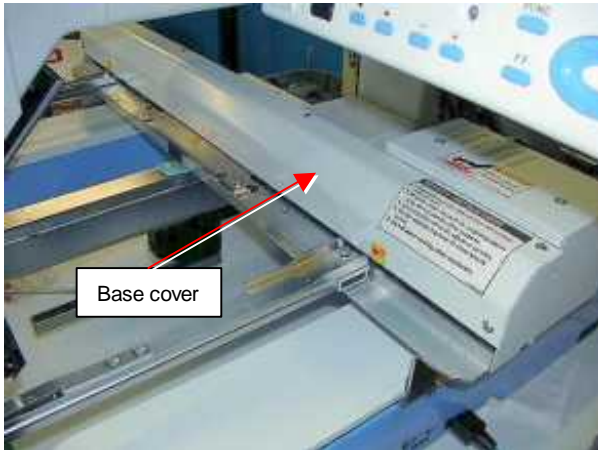

2. Remove 2 setscrews and disconnect the remove sensor board. for sensor cable .

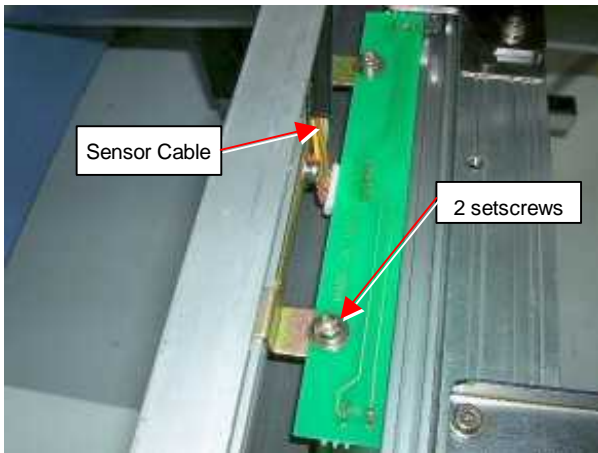

3. Installment of Position sensor board will be opposite procedure from Procedure 2.

**<Note>**

Detecting plate should be positioned at the center of sensor of Position sensor board.

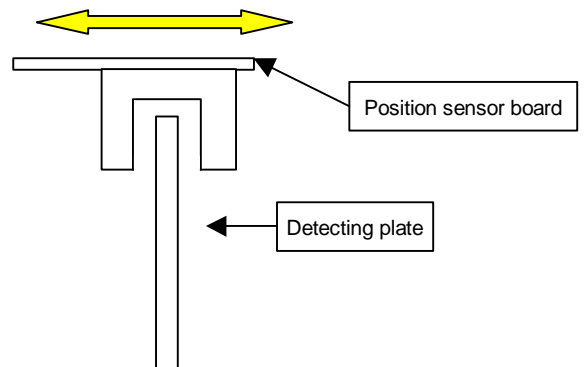
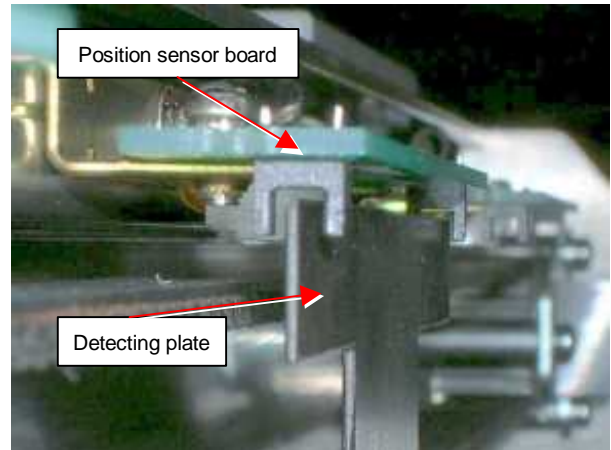

**<Note>**

[ 13-6 Coordinate registration for Positioning sensor ] should be done at the time of replacement of Positioning sensor.

Adjustment of Position sensor board for X axis is done.

<Note>

Please turn off machine power.

1. Remove Cover F

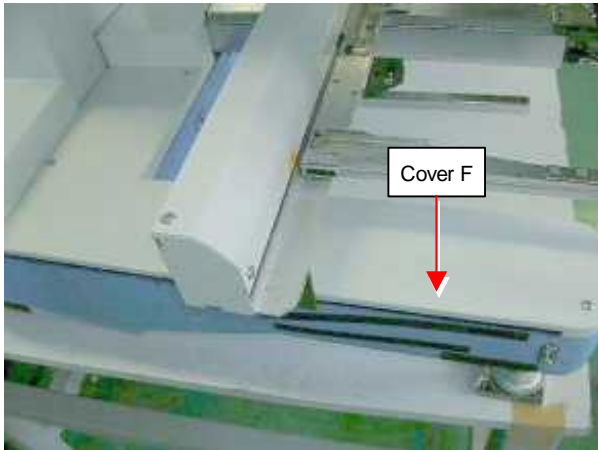

2. Remove 2 setscrews and disconnect the remove sensor board. for sensor cable .

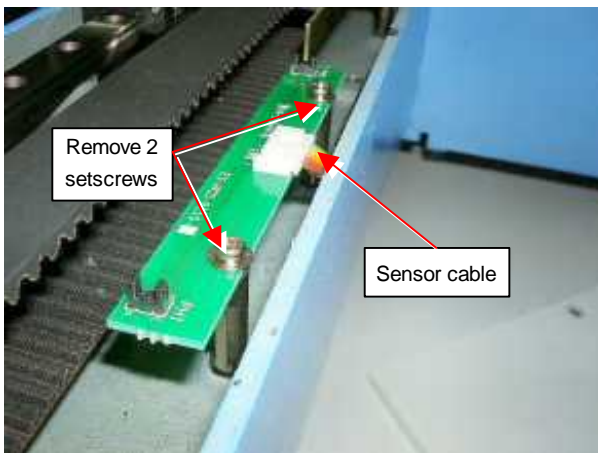

3. Installment of Position sensor board will be opposite procedure from Procedure 2.

<Note>

Detecting plate Y should be positioned at the center of sensor of Position sensor board.

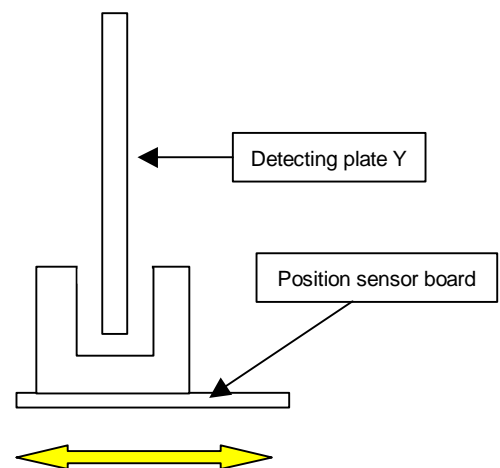
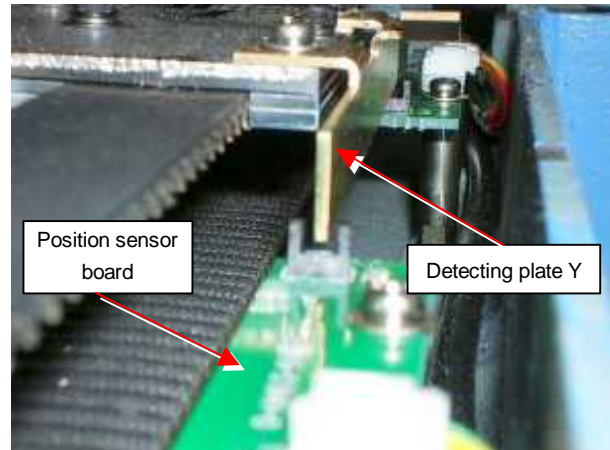

<Note>

[ 13-6 Coordinate registration for Positioning sensor] should be done at the time of replacement of Positioning sensor.

Adjustment of Position sensor board is done.

## 3-8 Transmission unit

3-8-1 Adjustment of timing belt tension

3-8-2 Exchange of timing belt

3-8-3 Exchange of main shaft timing board

3-8-4 Adjustment of detecting slit and timing slit

# Adjustment of timing belt tension

3-8-1

1. Referring to [2-2 Removal of outer covers], remove cover H.



2. Loosen the screw on tension ass'y. (Fixing screw 2 pcs)



3. Loosen fixing nut of tension block about 60 degrees.

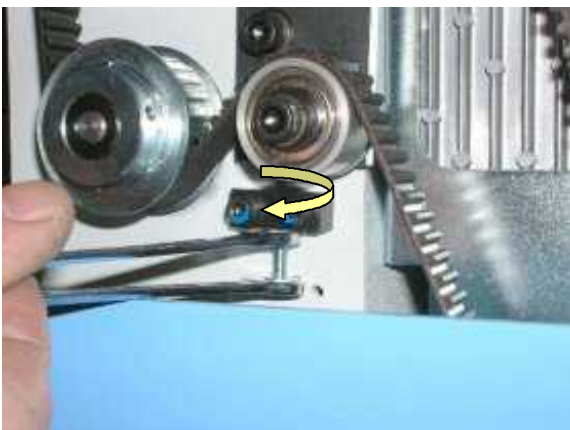

4. Adjust gaps between "Tension ass'y" and "Tension block" to [6.5 to 7.0mm] by adjusting bolt.

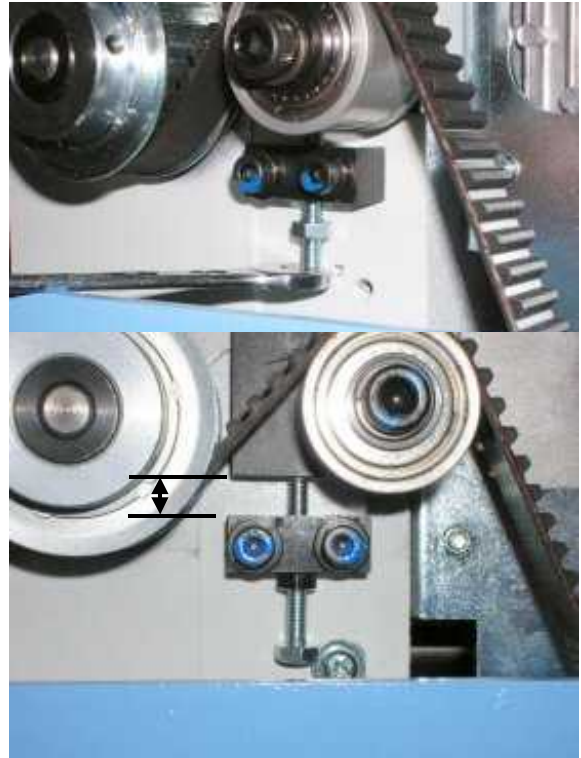

5. Fix tension ass'y (Fixing screw 2 pcs)

Tighten lock nut on tension block.



6. Return cover H. to previous places to finish.

# Exchange of timing belt

3-8-2

1. Referring to [2-2 Removal of outer covers], remove cover H.



2. Remove pointer. (Fixing screw 1 pcs)



3. Loosen the screw on tension shaft ass'y.  
(Fixing screw 2 pcs)



4. Loose fixing nut of tension block about 60 degrees.



5. Loosed the adjusting bolt.

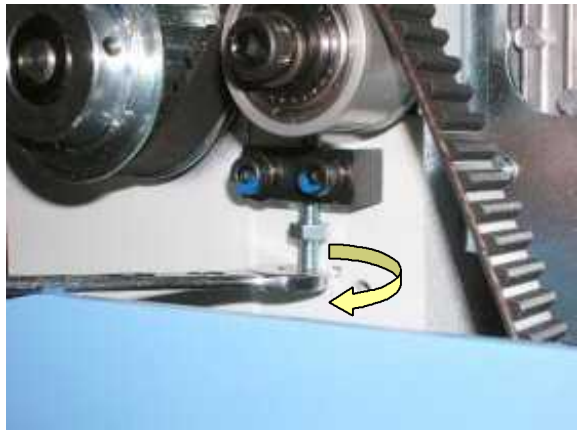

6. Take off the timing belt.



7. Take off the timing belt from motor pulley.



8. Exchange belt to good one.

9. Install each parts in reverse order.

For installation and adjustment of each part,  
please refer to respective manuals.

Referring to [3-8-1 Adjustment of timing belt tension],  
adjust tensile strength of timing belt.

Check and adjust following timing to finish.

- (1) lowest needle point
- (2) Rotary hook timing.
- (3) Thread cut timing.

1. Exchange main shaft timing board by the bellow process. Main shaft timing board consists of detecting slit board and timing slit board as showed bellow.

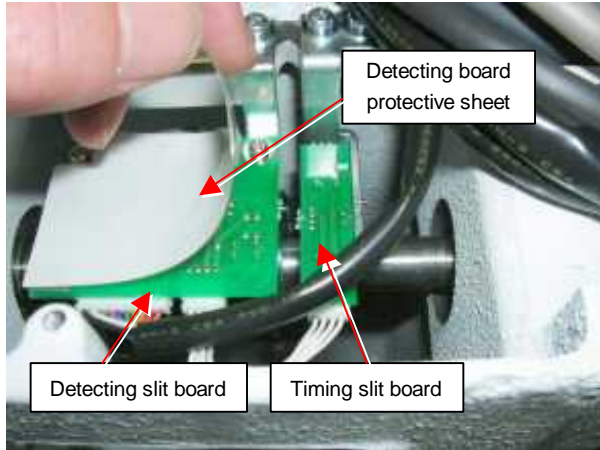

2. Take out detecting slit board.

Remove detecting board protective sheet of Step 1 and remove 2 setscrews as showed bellow. Take out timing cord and encoder relay cord.

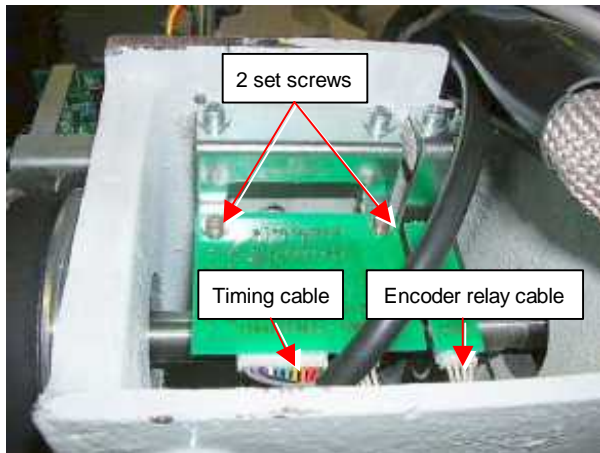

3. Take our timing slit board. Remover 2 set screws and take out encoder relay cord.

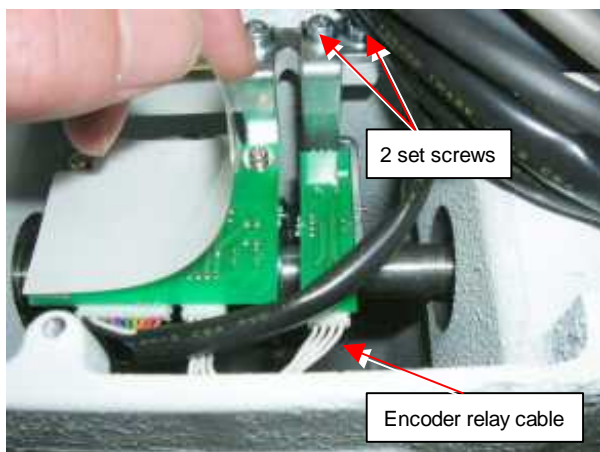

4. Put detecting slit board. Do the opposite procedure of step 2.

<NOTE> Put detecting slit not to touch sensors.

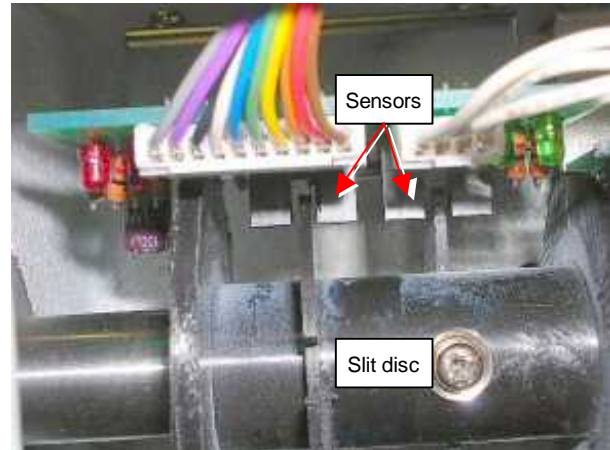

5. Put timing slit board. Do the opposite procedure of step 3.

<NOTE>Put timing slit not to touch sensors.

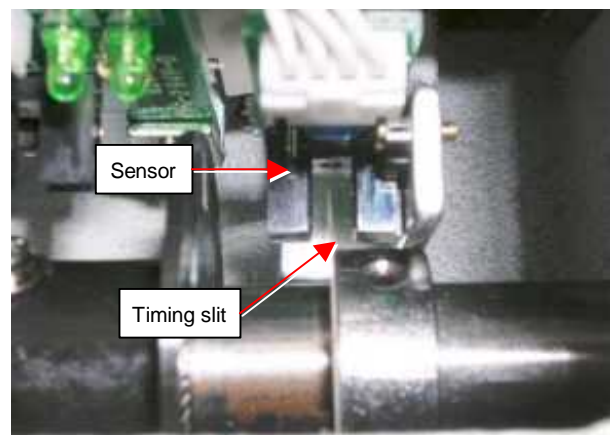

Finish of procedures.

1. Loosen the setscrew fixing detecting slit showed as bellow so that detecting slit can turn itself.

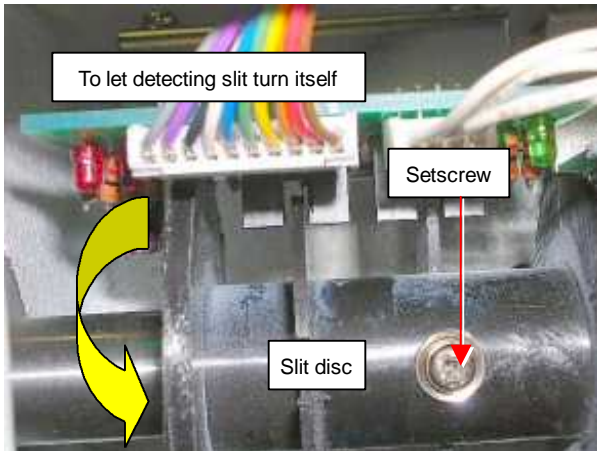

2. Set upper shaft to [ 0 degree ]



3. Turn detecting slit clockwise from pointer scale to set the position where LED4 goes out and tighten setscrews. (When detecting slit cover in L point sensor, LED4 goes out.)

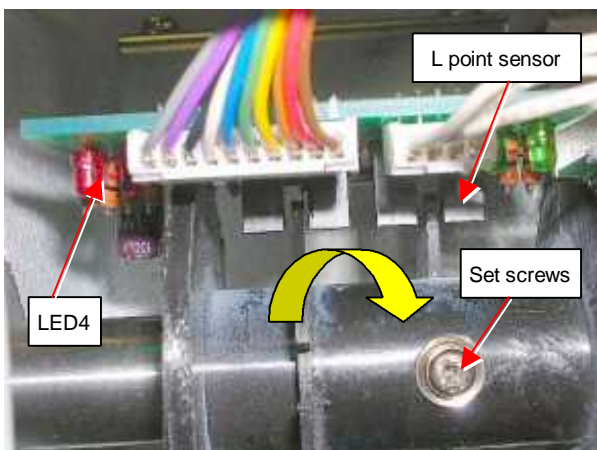

4. After main shaft timing board is set, turn the main shaft and confirm that LED4 goes out at 0 degree (L point).

5. Check C-point.

Turn main shaft by hand and confirm turn-on the LED-3 between 270 degree to 284 degree.

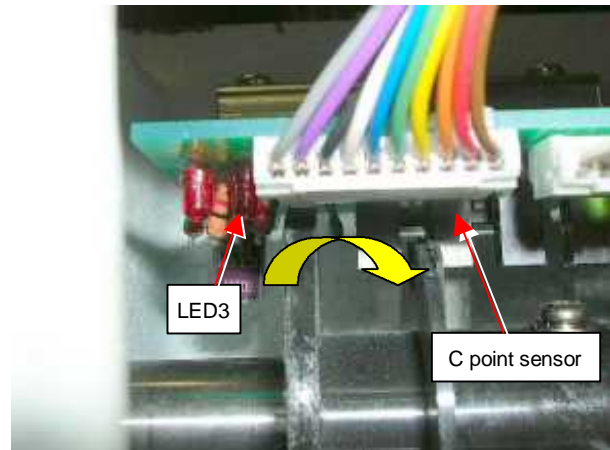

6. <Check>

should not touch sensor and timing slit for L and C.

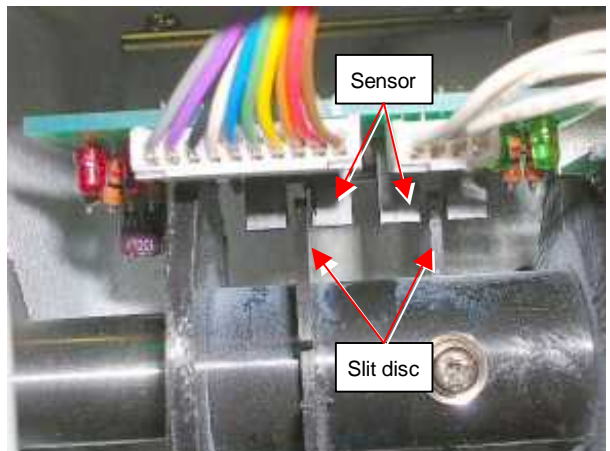

7. Loosen the setscrew fixing timing slit showed as bellow so that timing slit can turn itself.

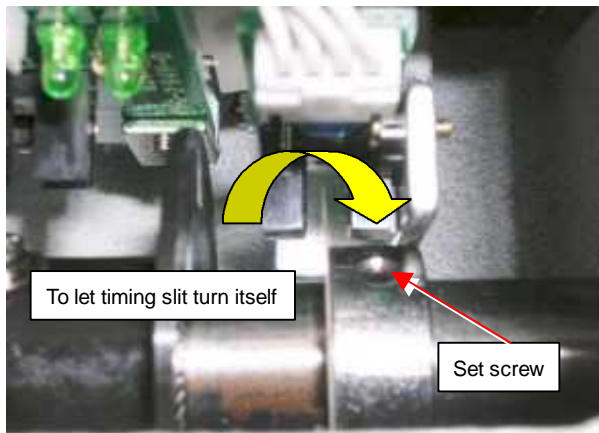

8. Adjust the distance between timing slit and timing board. As showed bellow, adjust the distance between timing slit and timing board to  $[ 0.7 + / - 0.2\text{mm} ]$  and tighten the screw.

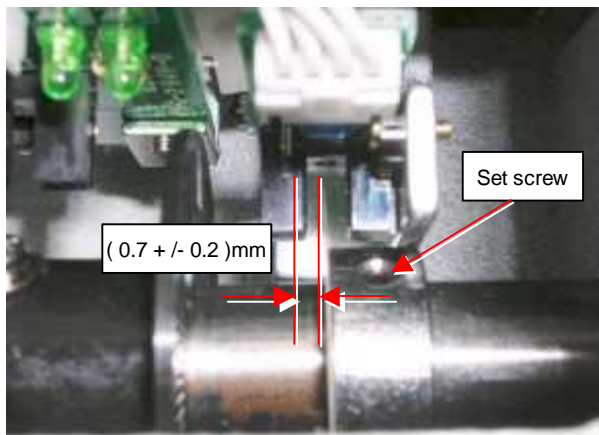

<NOTE>

Be careful not to bend timing slit, because it is very thin.

Finish of procedures.

## 4 Exchange and Setting of electric related component

4-1 Setting of dipswitch for CPU board

4-2 Exchange of fuse

4-3 How to remove Drive A Circuit Board Unit

4-4 Exchange of switching power supply and adjustment of power voltage output and of power failure detection

4-4-1 Exchange of switching power supply

4-4-2 Adjustment voltage output of 24V switching power supply

4-4-3 Adjustment voltage output of 36V switching power supply

4-4-4 Adjustment of power failure detection

4-5 Exchange of cooling fan (2 places)

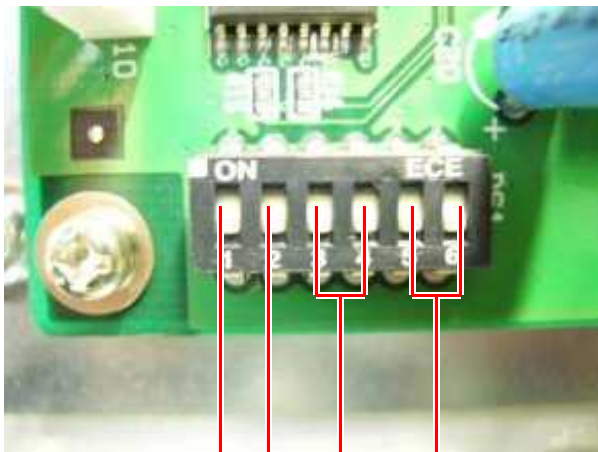

1	---	ON	: Initialization of backup date
		<input type="checkbox"/> OFF	: Do not initialize (Regular)
2	---	ON	: Maintenance mode
		<input type="checkbox"/> OFF	: Regular
3	---	<input type="checkbox"/> OFF	: Regular
4	---	<input type="checkbox"/> OFF	: Regular
5	---	<input type="checkbox"/> OFF	: Regular
6	---	<input type="checkbox"/> OFF	: Regular

External

Detail of External switch (Normally, dose not use at maintenance)

5	6	
ON	ON	: Forbid
ON	OFF	: Install mode by RS-232C (38400bbs)
OFF	ON	: Forbid
OFF	OFF	: Normal machine work ( Regular )

# Exchange of fuse

**<Check>**

Make sure that power switch is off before this work.

**<Note>**

Disconnect the plug during the work.

1. Open a fuse holder cap by pushing and turning counterclockwise with a flathead screwdriver.



2. After the fuse holder cap and fuse is pushed out, draw them out.



3. Remove fuse from fuse cap holder.

4. Exchange it to the auxiliary fuse.

**<Note>**

Do not use the other fuse than the auxiliary fuse(3SB6A)

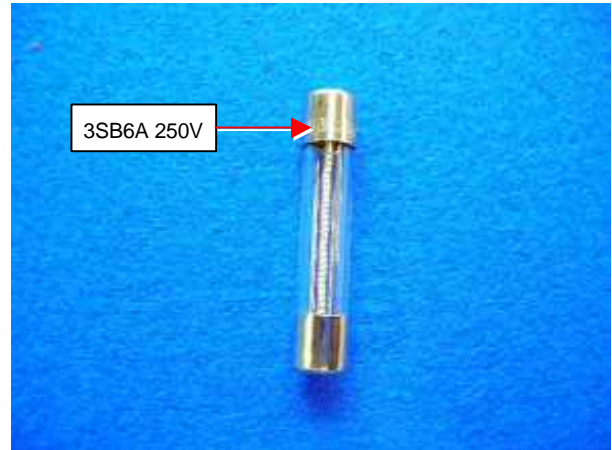

5. Set fuse in fuse holder cap.

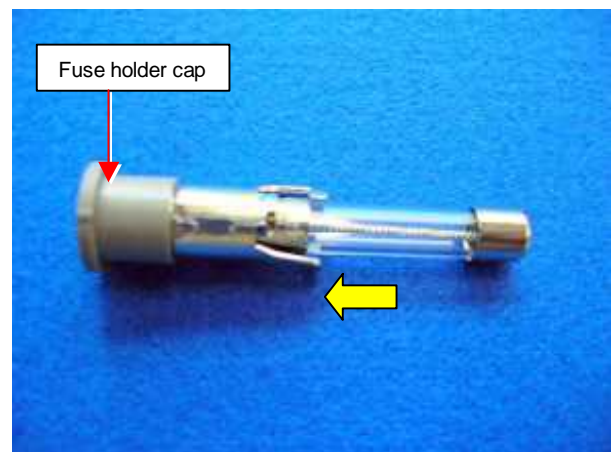

6. Set them in fuse holder and close the cover by turning clockwise with a flathead screwdriver.



\* End of process.

**<Note>**

Disconnect the plug during the work.

\* Remove outer cover (right), referring to [ 2-2 How to remove outer cover ]

1. Remove all the harness connected to Drive A Circuit Board.

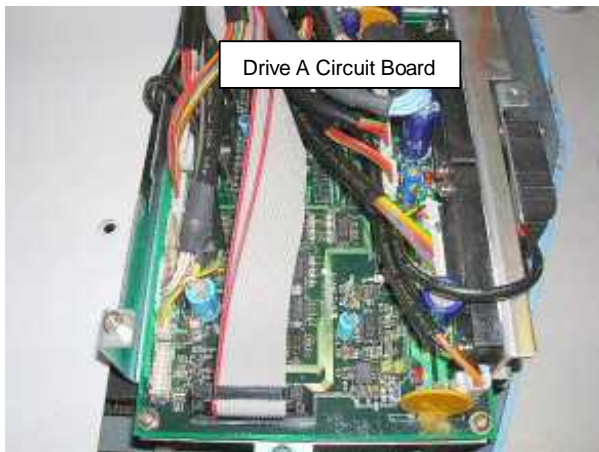

2. Remove earth cable of DC 24 power source cable and X-motor cable from bracket.

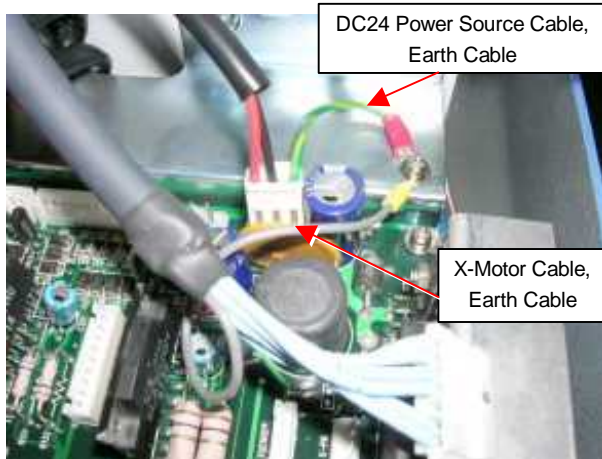

3. Remove Drive A Circuit Board.

Remove screws (total 3 places) as showed bellow.

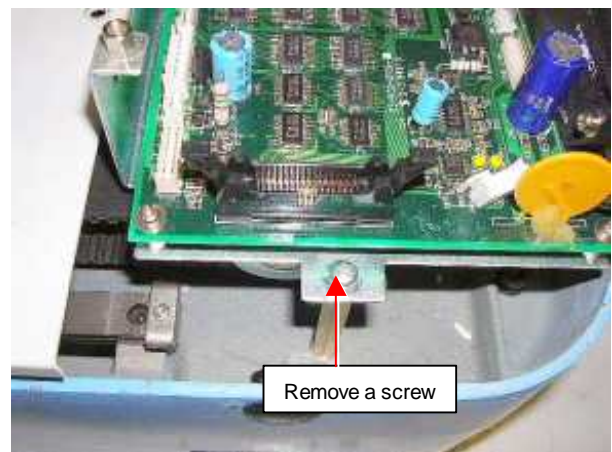

4. Take out Drive A Circuit Board.



# Exchange of switching power supply

1. Remove Drive A Circuit Board Unit, referring to [ 4-3 How to remove Drive A Circuit Board Unit ]

2. Remove Cover G ass'y by unscrewing total 4 screws at positions as below.

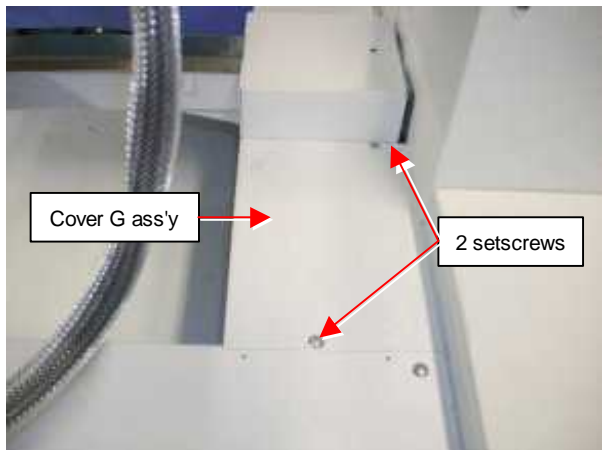
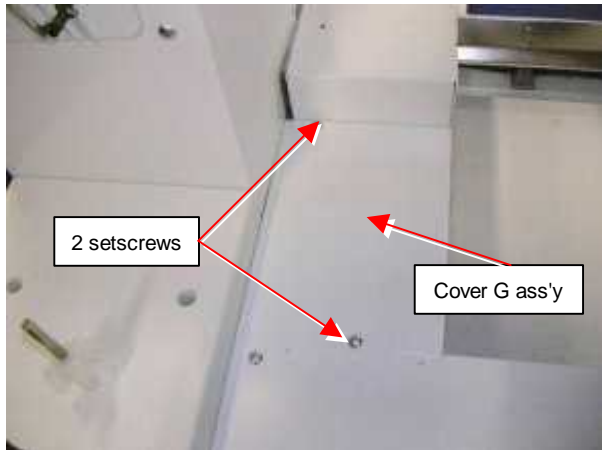

3. Remove Power Supply cover B.

Remove the mounting screw as showed bellow.

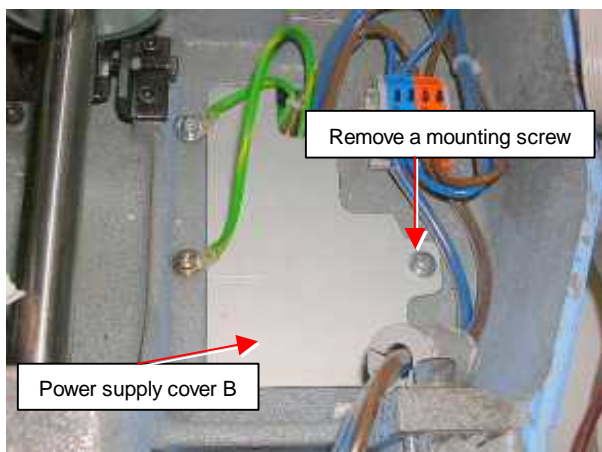

4. Remove the switching power supply cable. (2 places)

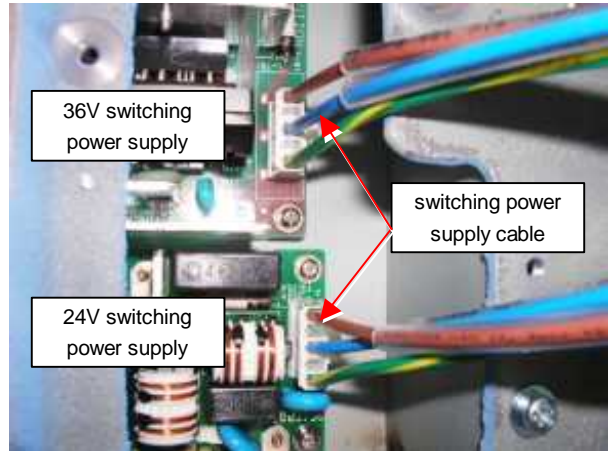

5. Remove Power Supply Cover A.

Unscrew the mounting screw as showed bellow.

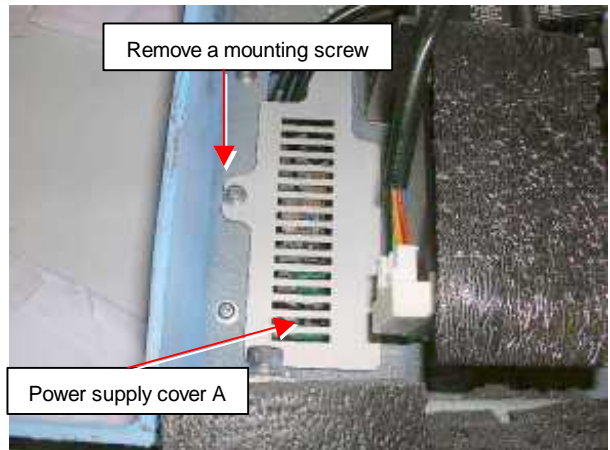

6. Remove DC Power Supply cables (2) from Switching Power Supply (2).

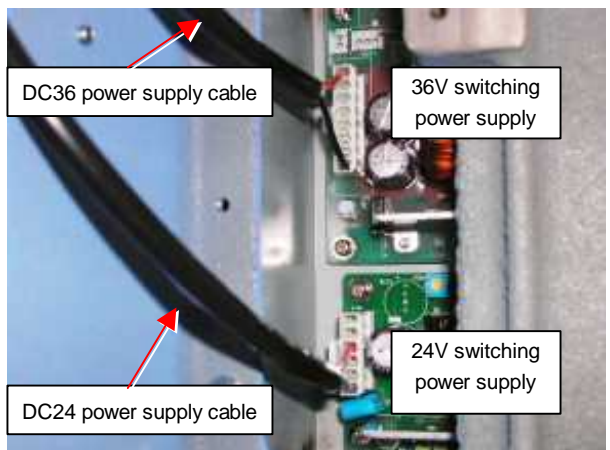

## 7. Remove Power switch assy box

Remove 4 screws as shown bellow.

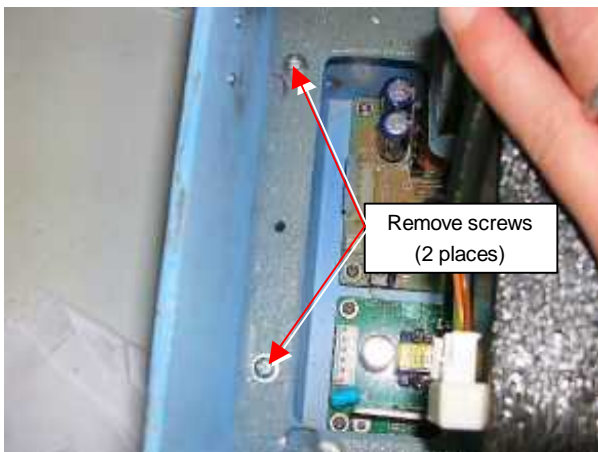
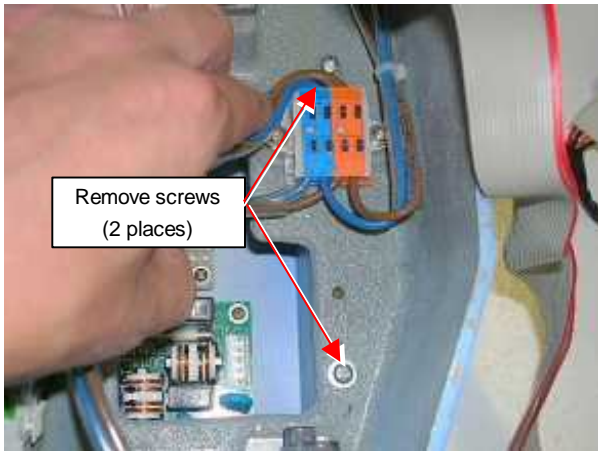

## 8. Exchange switching power supply

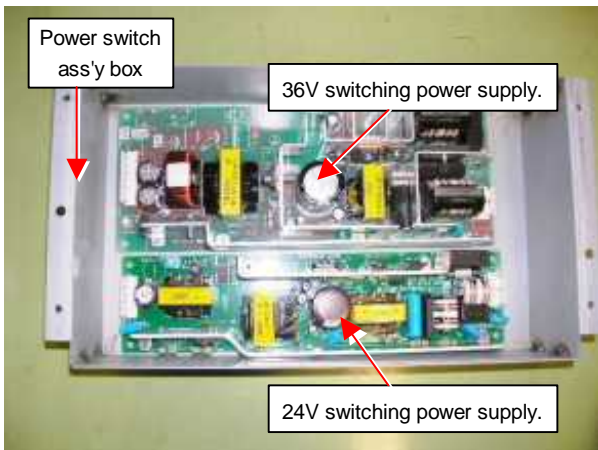

## 9. Check if Power switch assy box is not set upside down.

Sides where corners are cut shall come to downside. And sides where VRs of Switching Power Supply exist shall come to left.

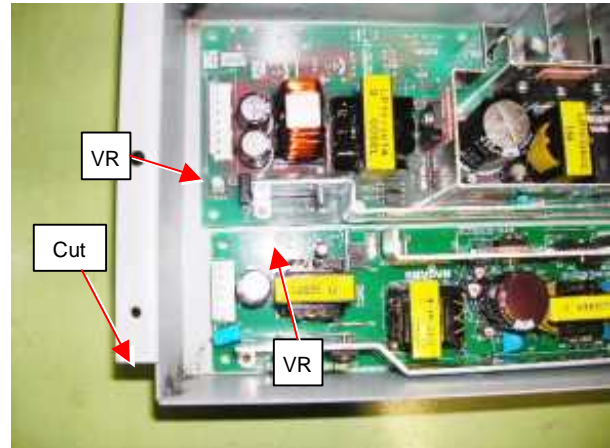

## 10. Procedures are finished after returning Power Switching Power Supply back to previous position, wiring and returning Drive A Circuit Board Unit to previous position.

(Please use digital Tester for this work.)

<Check>

Make sure that power switch is off before this work.

1. Remove outer cover (right), referring to [ 2-2 How to remove outer cover ]

2. Remove outer Cover G ass'y

3. Remove power supply cover A.

Remove the mounting screw as showed bellow.

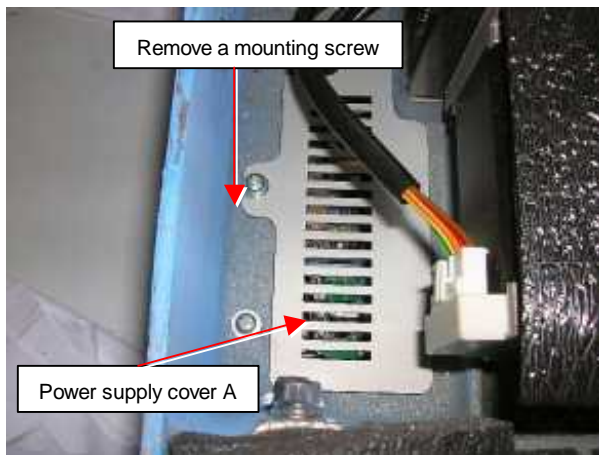

4. Set the digital tester range to DC.



5. Put digital tester pin in CN28 (DC24 power supply cable) of Drive A circuit board.

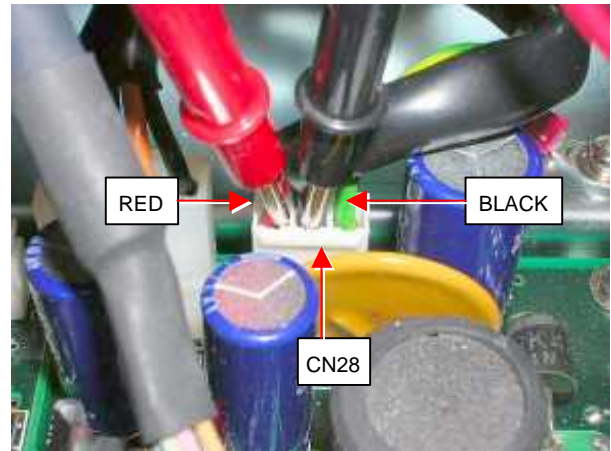

<Note>

\* Put RED of digital tester in No.1 (RED) of DC24 power supply cable.

\* Put BLACK of digital tester in No.2 (Black) of DC24 power supply cable.

6. Turn on the main switch and set [ 24.6 V +/- 0.1V ] by turning VR (Volume) of 24V switching power supply.

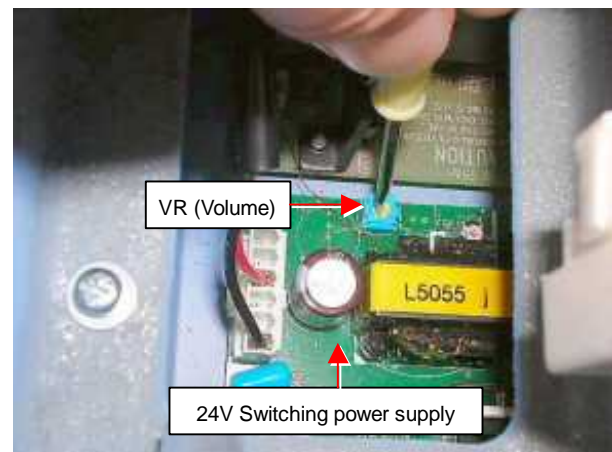

\* End of process.

\* Put back the cover.

(Please use digital Tester for this work.)

<Check>

Make sure that power switch is off before this work.

1. Remove outer cover (right), referring to [ 2-2 How to remove outer cover ]
2. Remove outer Cover G ass'y
3. Remove power supply cover A.

Remove the mounting screw as showed bellow.

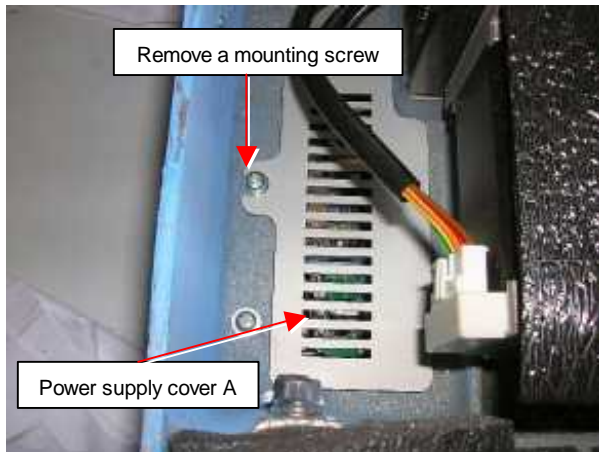

2. Set the digital tester range to DC.

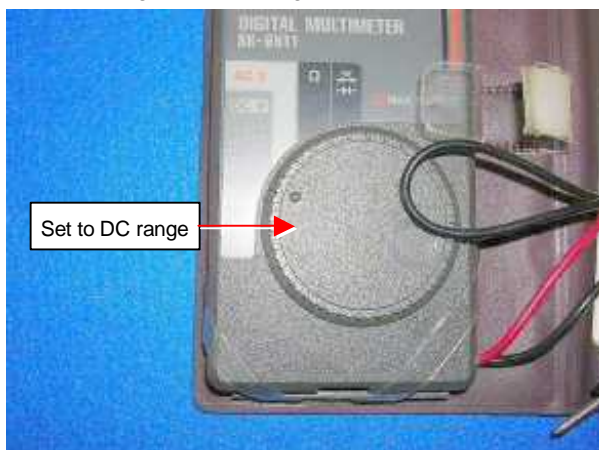

5. Put digital tester pin in CN27 (DC26 power supply cable) of Drive A circuit board.

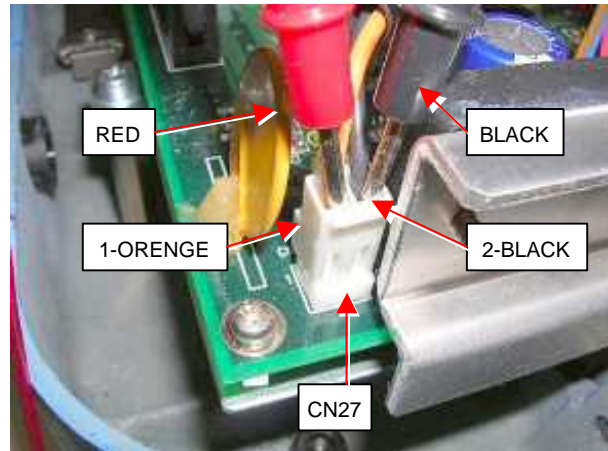

<NOTE>

- \* Put RED of digital tester in No.1 (ORENGE) of DC36 power supply cable.
- \* Put BLACK of digital tester in No.2 (BLACK) of DC36 power supply cable.

6. Turn on the main switch and set [36.0V +/- 0.1V] by turning VR (Volume) of 36V switching power supply.

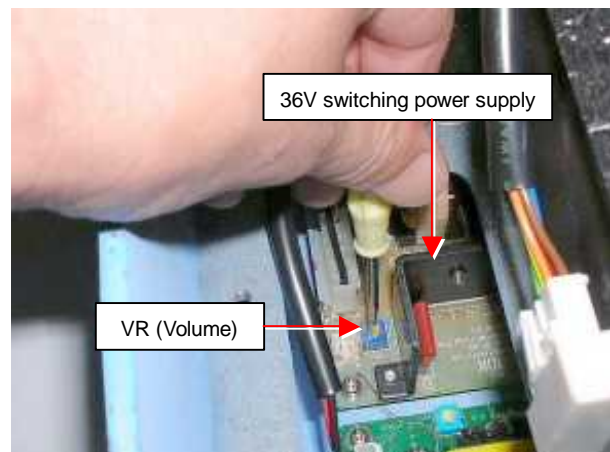

\* End of process.

\* Put back the cover.

(Please use digital Tester for this work.)

**<Check>**

Make sure that power switch is off before this work.

Please confirm level of 24V switching power output , [24.6 +/- 0.1V], and level of 36V switching power output, [36.0 +/- 0.1V], by a digital tester with reference to [4-4-2 Adjustment of 24V Switching Power Output] and [4-4-3 Adjustment of 36V Switching Power Output].

1. Turn counterclockwise VR1 of drive A circuit board to the end.

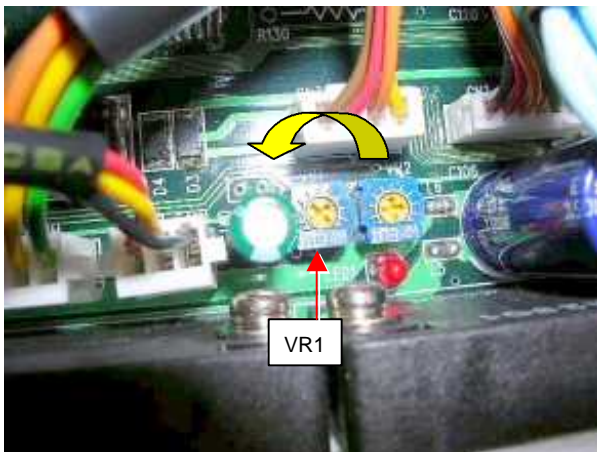

2. Put the black pin (-) of digital tester to GND terminal of drive A circuit board.

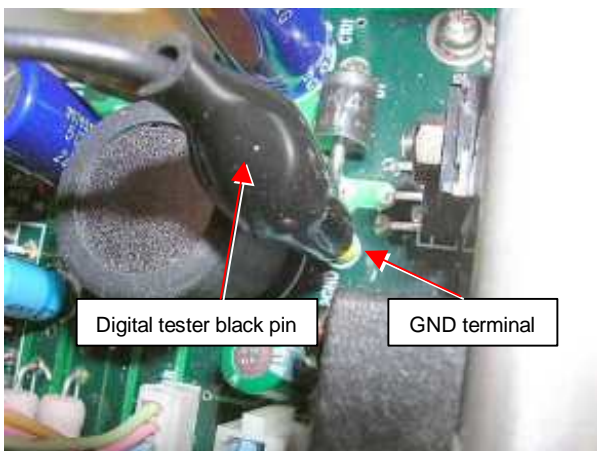

3. Put the red pin (+) of digital tester to TP2 terminal of drive A circuit board.

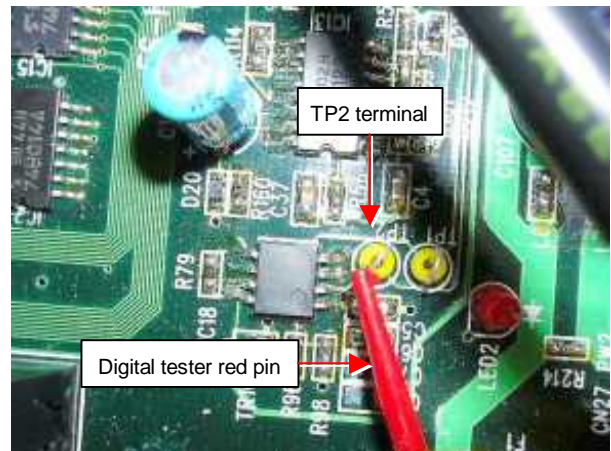

4. Turn on the main switch and set the range of [2.2V +/- 0.1V ] by turning VR2 ( Volume ) slowly.

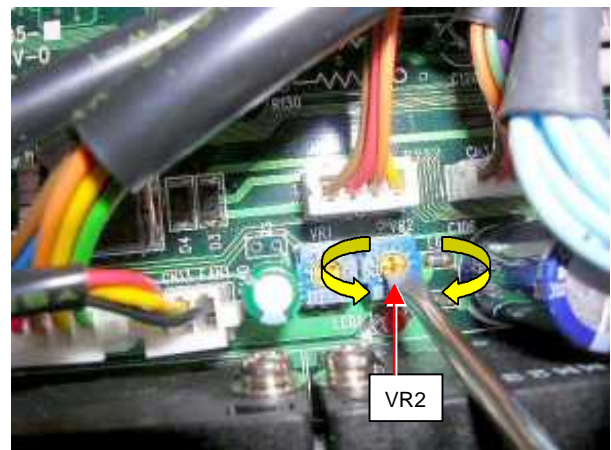

\* End of process

# Exchange of cooling fan (2 places)

<Note> Disconnect the plug during the work.

\* Remove Drive A circuit board unit, referring [ 4-3 How to remove Drive A circuit board unit ]

## 1. Exchange of the cooling fan for PM driver.

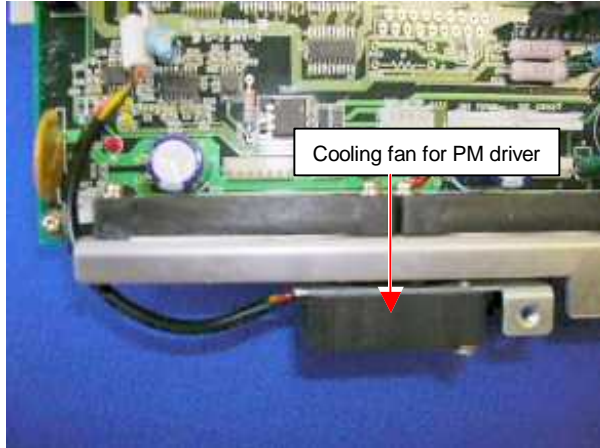

2. Remove 2 mounting screws as showed bellow and take out the cooling fan.

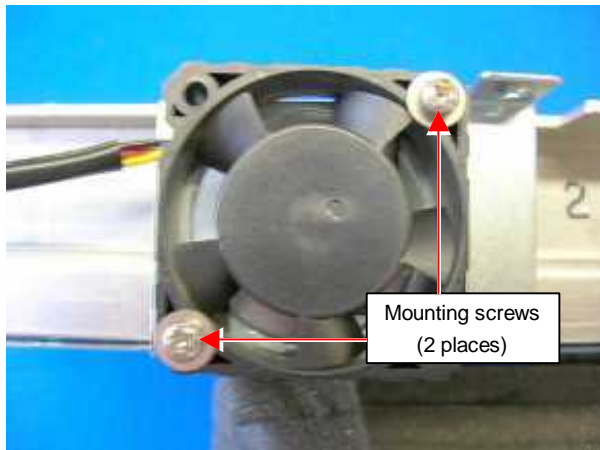

3. When you put the replacement cooling fan for PM driver, please conform the sticker side and PMD board bracket as showed bellow.

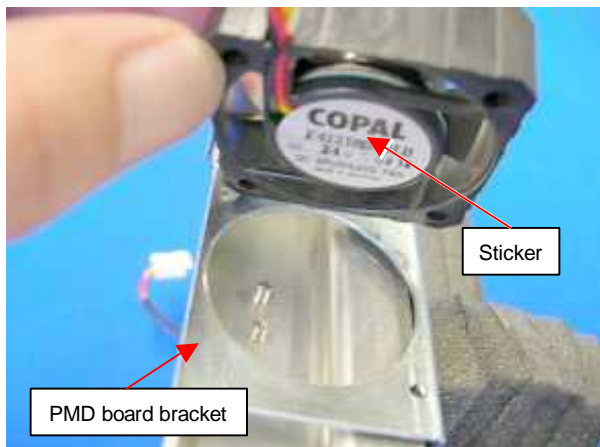

## 4. Exchange of cooling fan for pulse motor.

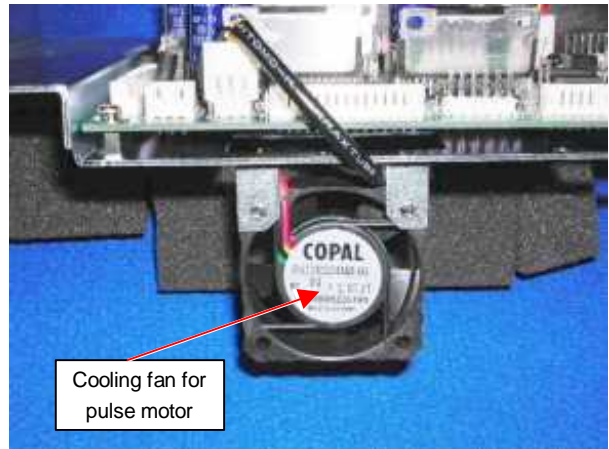

5. Remove 2 mounting screws as showed bellow and take out the cooling fan.

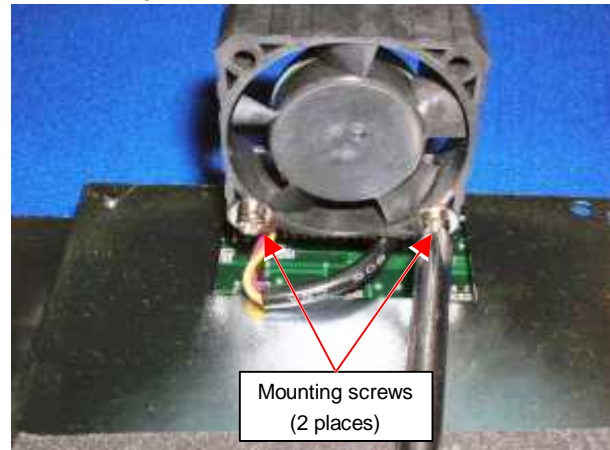

6. When you put replacement cooling fan, turn out the sticker side as showed bellow.

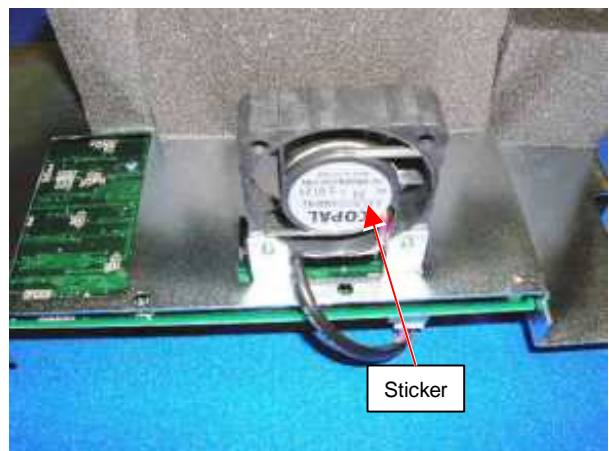

End of process.

Return Drive A circuit board unit and outer covers to previous positions.

## 5 Parts Replacement in control box and setting

5-1 Open and remove front panel from control box

5-1-1 Open the front panel on the control box

5-1-2 Remove ATA LCD board

5-2 Dip switch setting for ATA / LCD board

# Open and remove front panel from control box

## Open the front panel on the control box

5-1

5-1-1

<Check> Please check down machine power completely.

1. Remove four setscrews behind of control panel

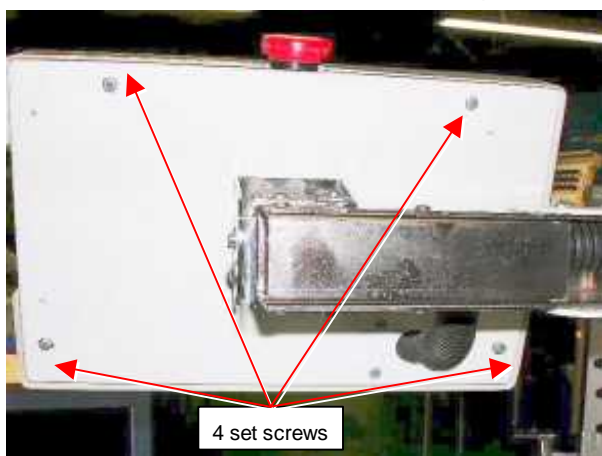

2. Open control panel like following picture.

(Open the cover from right side)

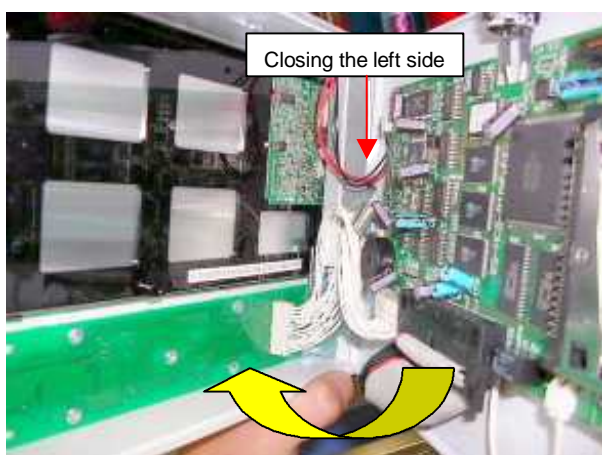

<Note>

Please do not wide open on the left side.

(Possible, make damage to wiring cable and electric board)

Please do not turn on power when inverter cover (refer to the bellow), otherwise the machine might be damaged.

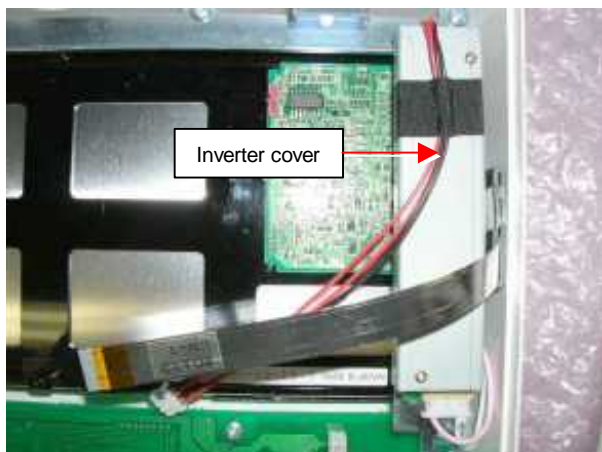

3. Disconnect Inverter power cable.

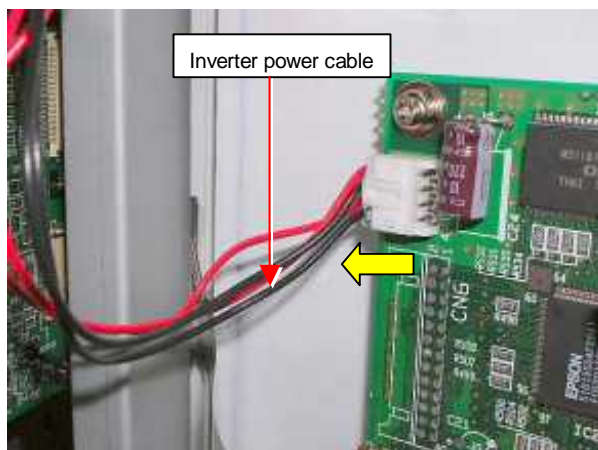

4. Disconnect for LCD-SW cable



5. Disconnect LCD-S cable.

1: Pull stopper on CN7(ATA/LCD board)

2: Pull out the LCD-S cable.

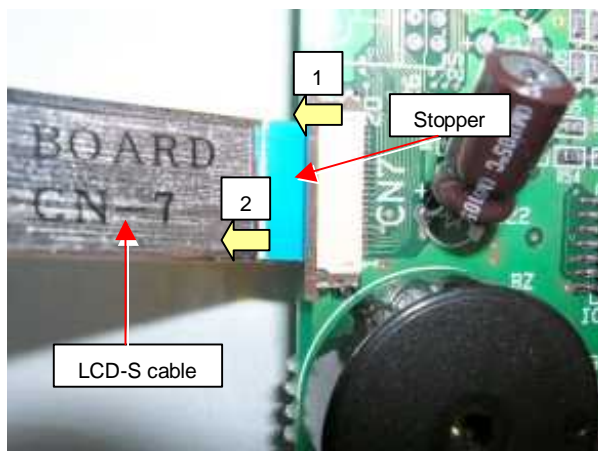

\* Finish of procedures

For assemble and close this panel: Please opposite steps of this procedure.

1. Disconnect emergency SW cable

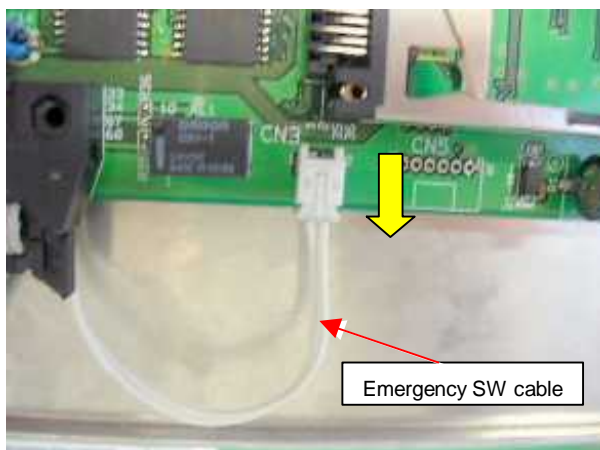

2. Disconnect DISP cable. (Please off stopper first)

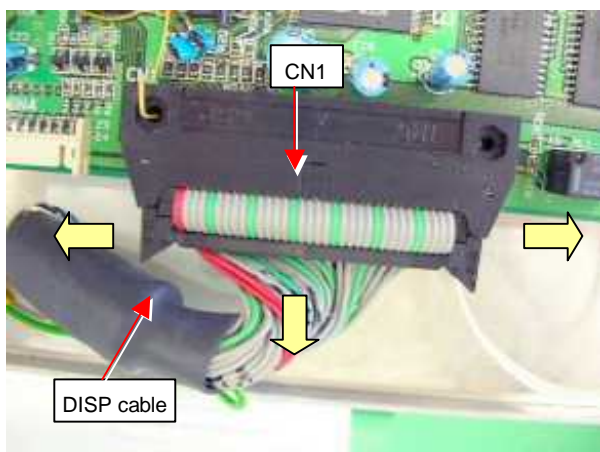

3. Remove ATA/LCD board

Remove four setscrews

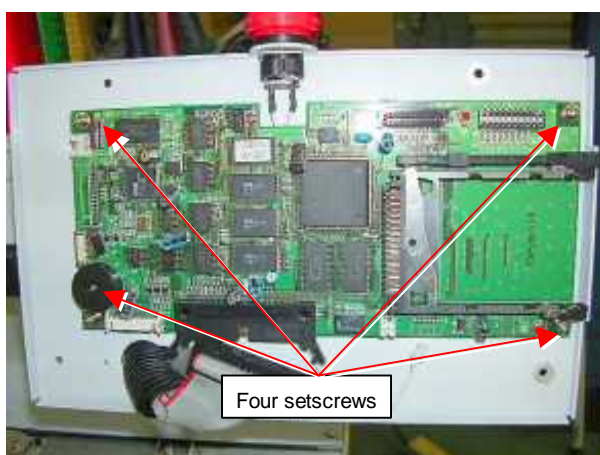

Finish of procedures

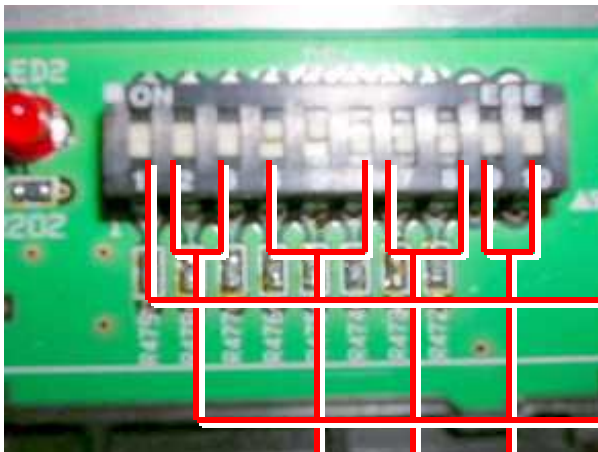

1	-----ON	: Initialize back up data
	<input type="checkbox"/> OFF	: Non Initialize(Regular)
2	-----OFF	: Regular
3	-----OFF	: Regular
4	-----ON	
5	-----ON	: Regular <input type="checkbox"/> Color LCD Size
6	-----OFF	
7	-----OFF	: Regular <input type="checkbox"/> External
8	-----OFF	
9	-----OFF	: Regular
10	-----OFF	: Regular

Detail of External switch (Normally, dose not use at maintenance)		
7	8	
ON	ON	: Forbid
ON	OFF	: Erase of language data.
OFF	ON	: Forbid
OFF	OFF	: Normal machine work(Regular)

## 6 Inverter setting

### 6-1 Inverter setting

6-1-1 Replace and wiring inverter

6-1-2 Remove inverter

6-1-3 Replace Inverter for 100-120V / FR-S510W

6-1-4 Replace Inverter for 200-230V / VFNC1

### 6-2 Setting Inverter

6-2-1 About Inverter

6-2-2 FR-S510W Parameters release the keep off setting

6-2-3 FR-S510W Setting parameters

6-2-4 FR-S510W Initialize parameters

6-2-5 VFNC1(S) Parameters release the keep off setting

6-2-6 VFNC1(S) Setting parameters

6-2-7 VFNC1(S) Setting extension parameter

6-2-8 VFNC1(S) Initialize parameters

# Replace and wiring inverter

6-1-1

**<Note>**

Inverter setting and wiring are different for 100V and for 200V. Please check your inverter specifications by sticker on the inverter.

\* For 100-120V type FR-S510W, please reference [6-1-2].

\* For 200-230V type VFNC1, please reference [6-1-3].

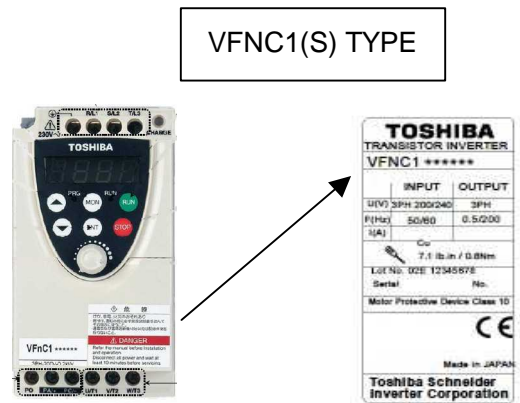
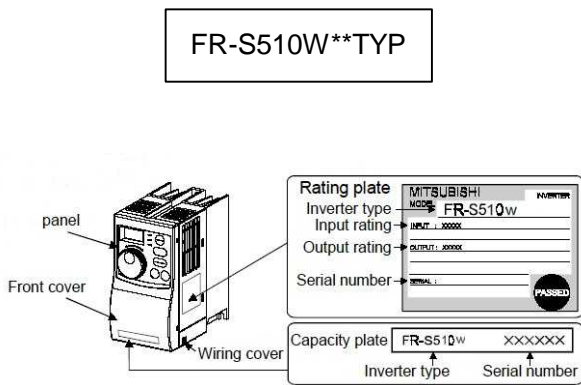

# Remove Inverter

6-1-2

(Please disconnect machine inlet from the wall.)

**<Check>**

Please check machine power off completely before replace inverter.

1. Remove outer cover left. Refer to [2-2 How to remove Outer cover left]
2. Remove Inverter unit from machine.  
Take off two screws and remove inverter unit from machine.

3. Disconnect Inverter cord use screwdriver.

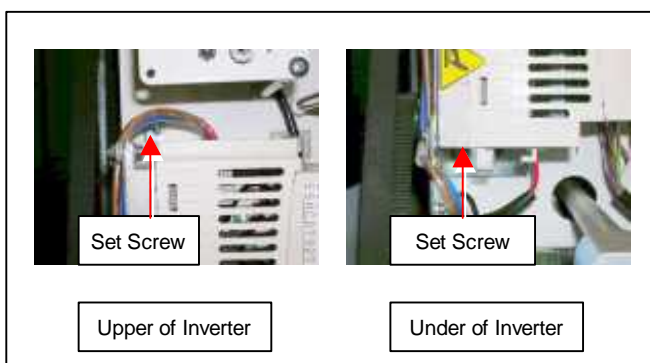
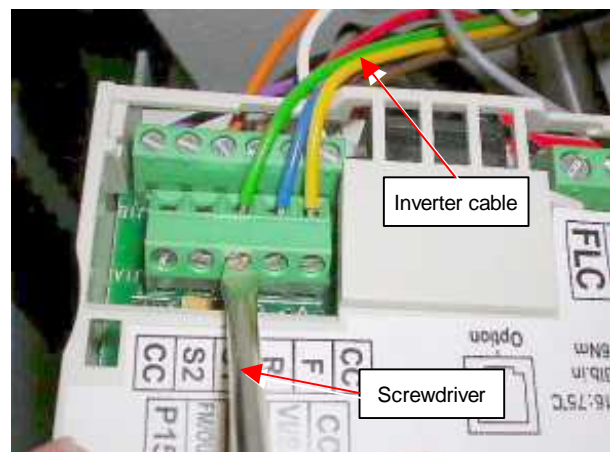

# Remove Inverter

6-1-2

4. Disconnect power cord use screwdriver.

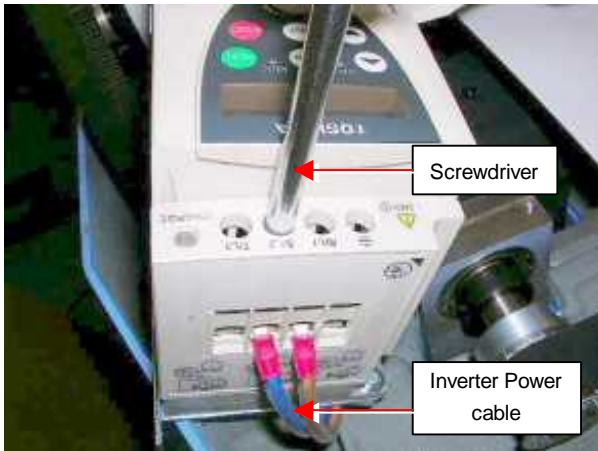

5. Disconnect Motor cable use by screwdriver.

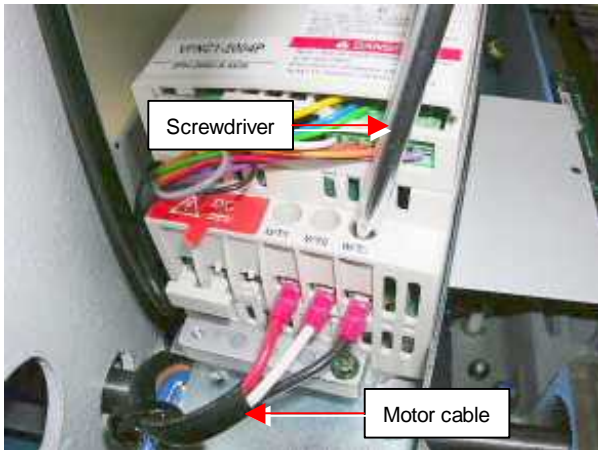

6. (In case of 200 - 230V / VFNC1 type inverter.)

Take off two cord clamps.

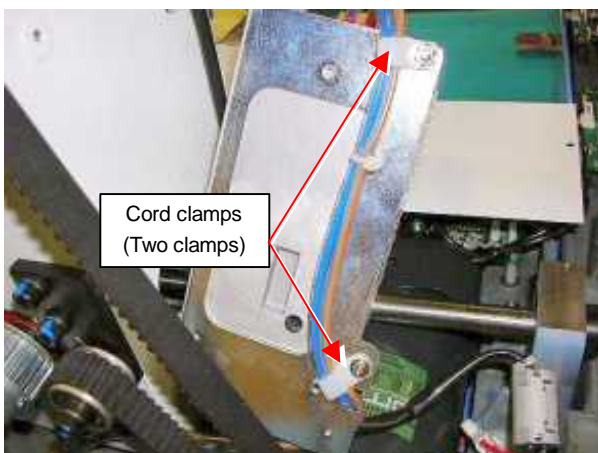

7. Open the cord clip and remove Power and Motor cable.

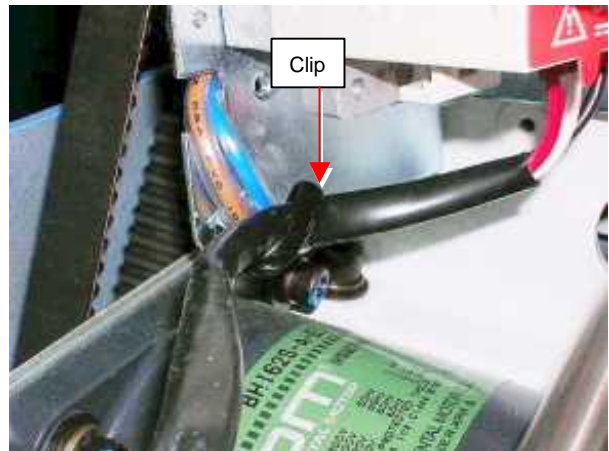

8. (In case of 200-230V / VFNC1 type inverter.)

Remove inverter bracket.

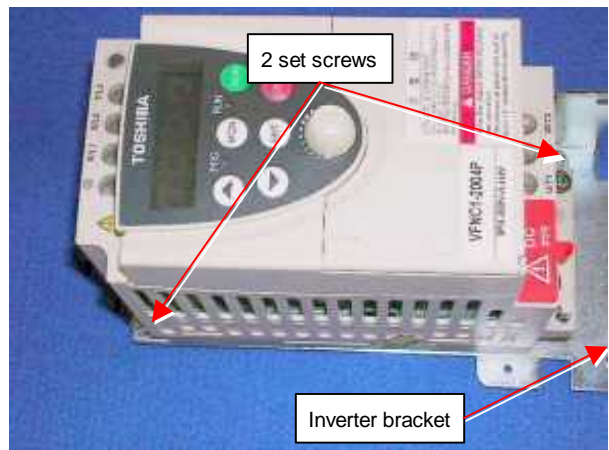

9. (In case of 100V - 120V / FR-S510W type Inverter.)

Remove Inverter bracket.

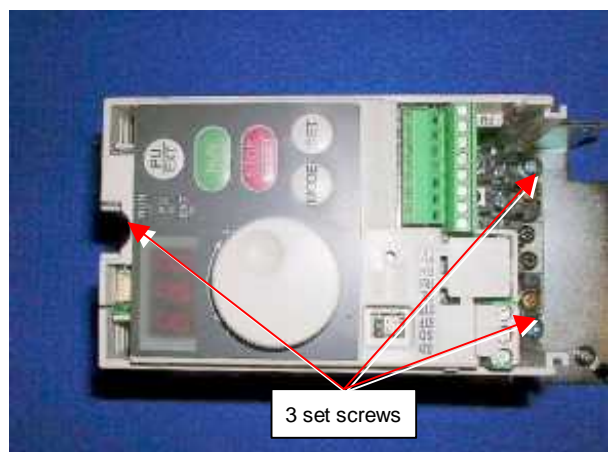

End of process.

# Replace Inverter for 100-120V / FR-S510W

6-1-3

(Please disconnect machine inlet from the wall.)

## <Check>

Please check machine power off completely before replace inverter.

## <Note>

Please check your replacement inverter type and machine Voltage specification before replace inverter.

\* Check following sticker information for Machine voltage.  
(100-120V.)

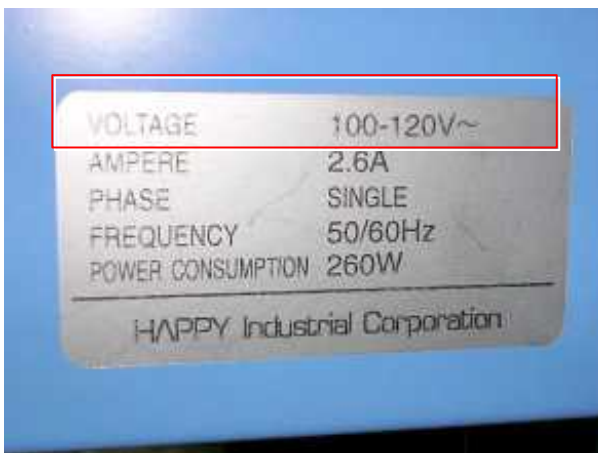

\* Check Inverter specification by following sticker on inverter.  
(FR-S510W.)

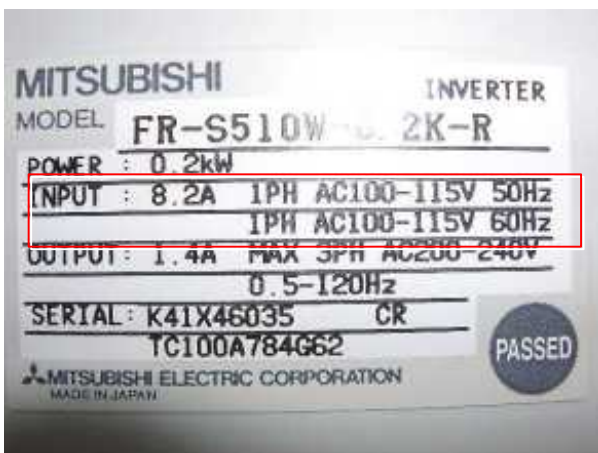

1. Pull and remove the Front cover.

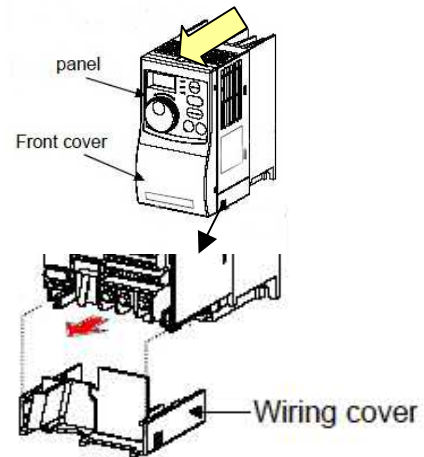

2. Set new inverter to inverter bracket.



3. Connect power cable to inverter.

Reference of [11-4 FR-S510W type Inverter wiring and parameter setting. (For 110V.)]

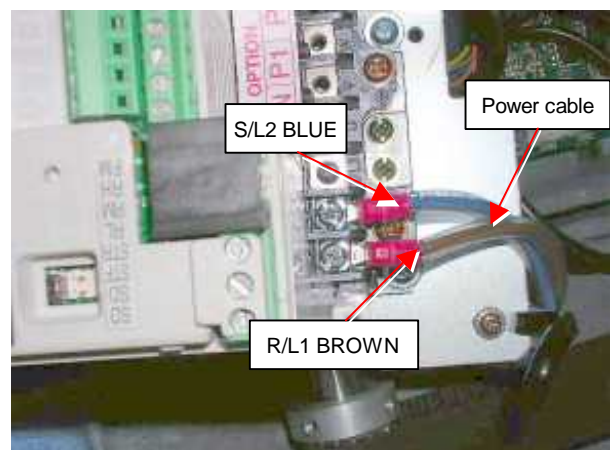

4. Connect main motor cable.

Reference of [11-4 FR-S510W type Inverter wiring and parameter setting. (For 110V)]

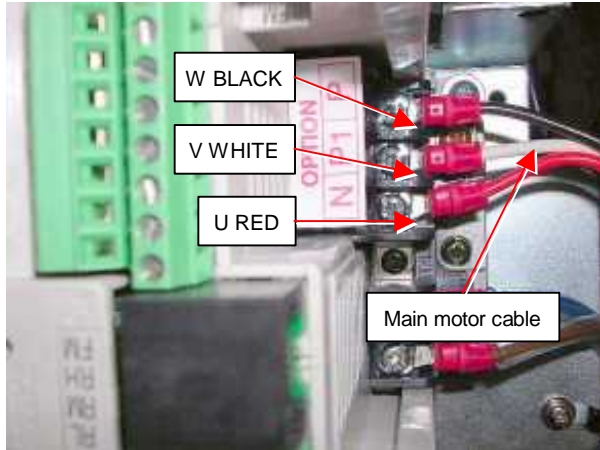

5. Set lower cover.

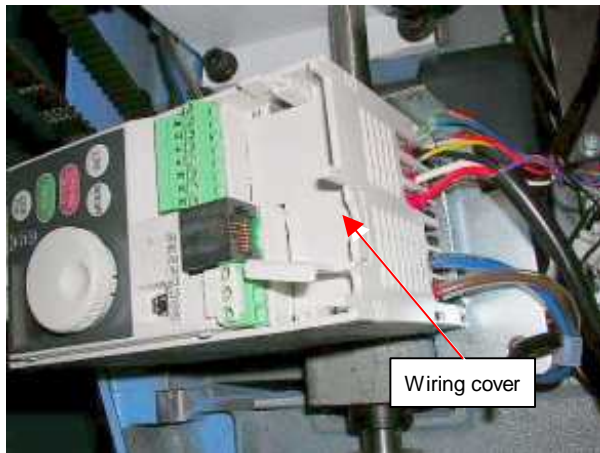

6. Fix Power and Motor cable by Clip for stays.

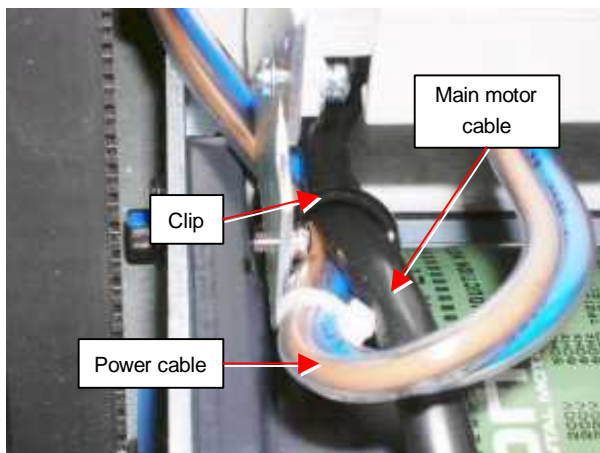

7. Connect Inverter cable. (Brawn cable then Black cable)

Reference of [11-4 FR-S510W type Inverter wiring and parameter setting. (For 110V)]

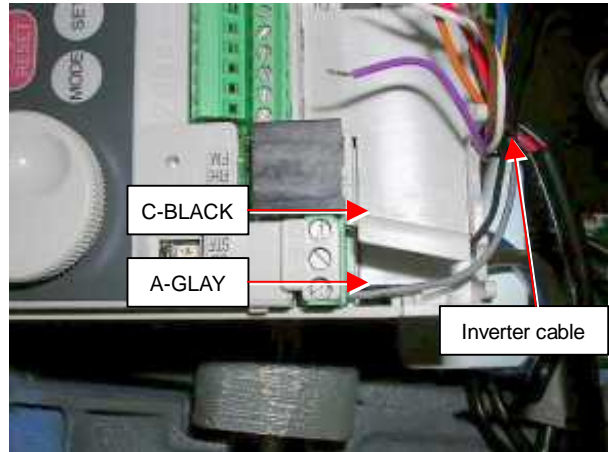

8. Connect Inverter cable (Purple, White, Brawn, Red, and Orange). Reference of [11-4 FR-S510W type Inverter wiring and parameter setting. (For 110V)].

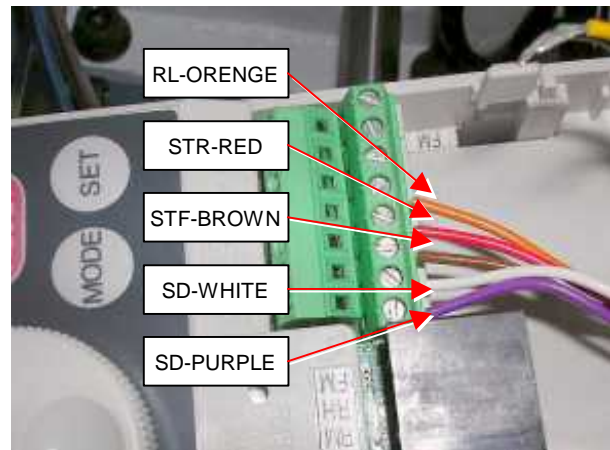

9. Connect Inverter cable. (Green, Blue, Yellow)

Reference of [11-4 FR-S510W type Inverter wiring and parameter setting. (For 110V)].

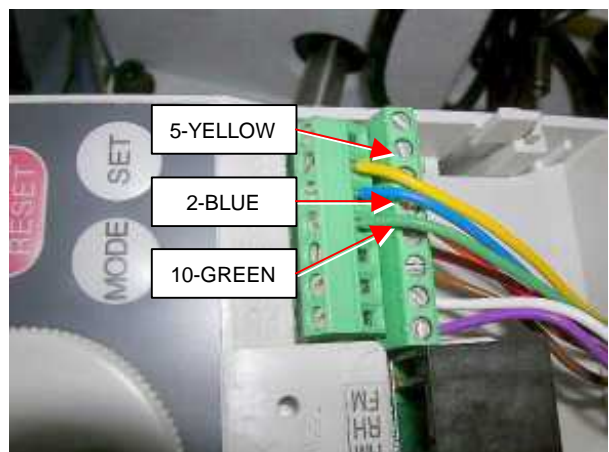

10. Set of Upper cover.



11. Set inverter unit to machine.



12. Bundle wires by clip.

<Note> Please bundle wires not brush any working parts.

(Shaft and Belt).

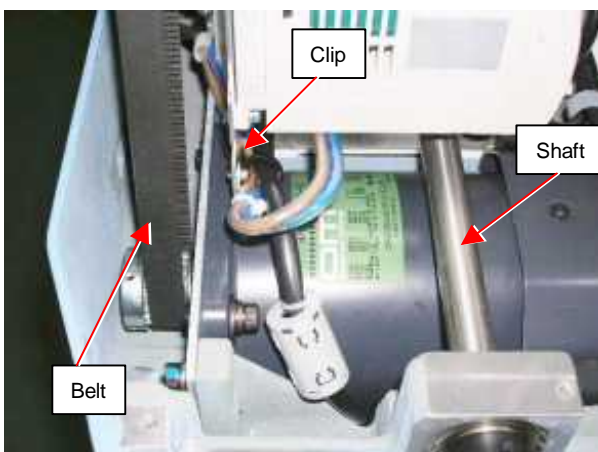

13. Please set machine speed by chapter [10-1 Adjustment of revolution].

End of process.

# Replace Inverter for 200-230V / VFNC1

(Please disconnect machine inlet from the wall.)

<Check>

Please check off of "Charge lamp" on inverter.

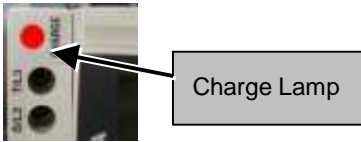

<Note>

Please check your replacement inverter type and machine Voltage specification before replace inverter.

\* Check following sticker information for Machine voltage.(200-230V)



\* Check Inverter specification by following sticker on inverter. (VFNC1)

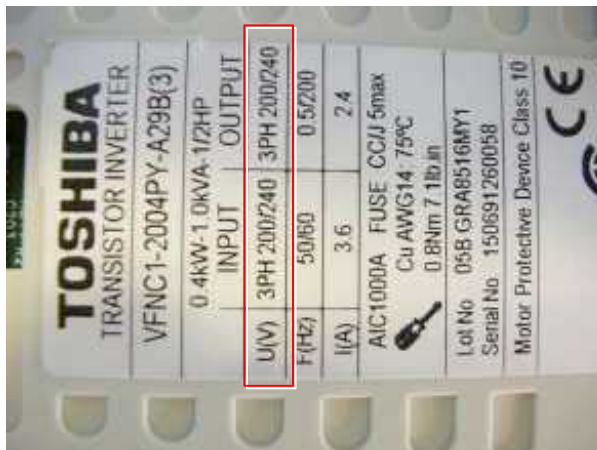

1. Set new inverter to inverter bracket.



2. Connect power cable to inverter.

Reference of [11-5 VFNC1(S) type Inverter wiring and parameter setting].

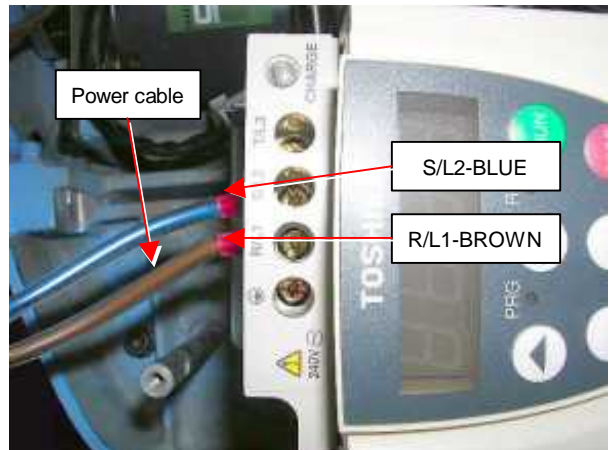

3. Connect main motor cable.

Reference of [11-5 VFNC1(S) type Inverter wiring and parameter setting].

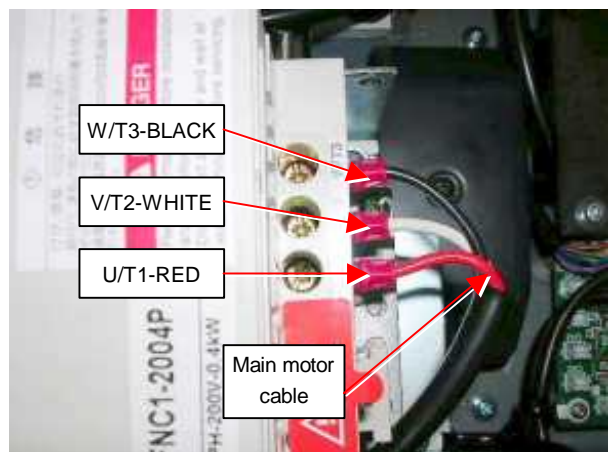

4. Open the protection cover



5. Connect Inverter cable. (Glary them Black).

Reference of [11-5 VFNC1(S) type Inverter wiring and parameter setting].

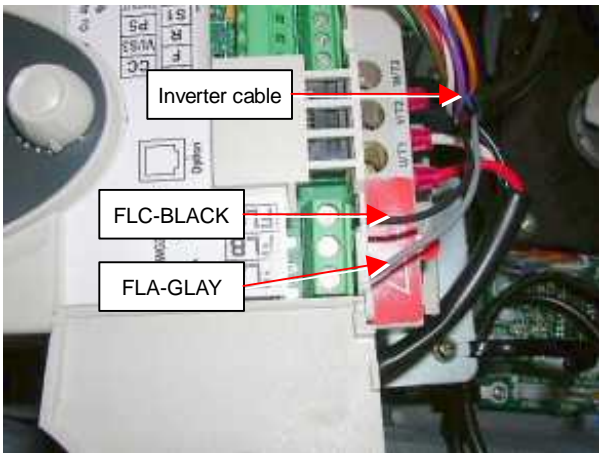

6. Connect Inverter cable (Purple, White, Brawn, Red, and Orange).

Reference of [11-5 VFNC1(S) type Inverter wiring and parameter setting].

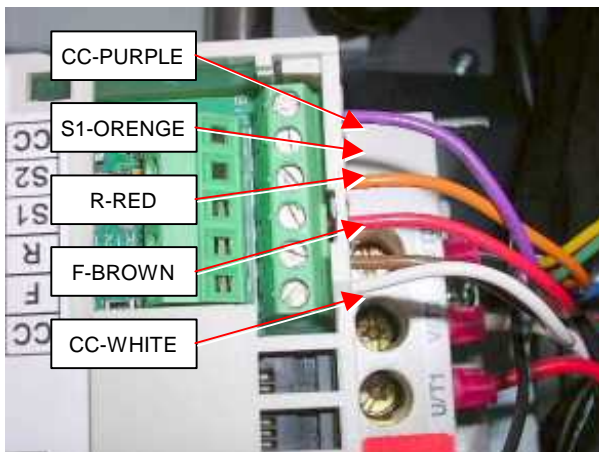

7. Connect Inverter cable. (Green, Blue, Yellow).

Reference of [11-5 VFNC1(S) type Inverter wiring and parameter setting].

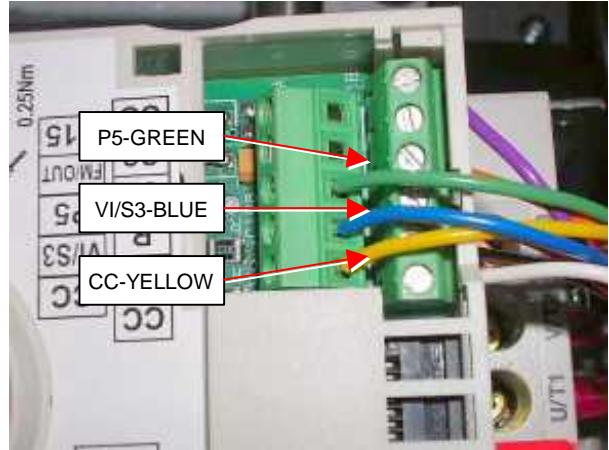

8. Close the protection cover.



9. Set inverter unit to machine.



10. Bundle wires by clip.

<Note> Please bundle wires not brush any working parts  
(Shaft and Belt).

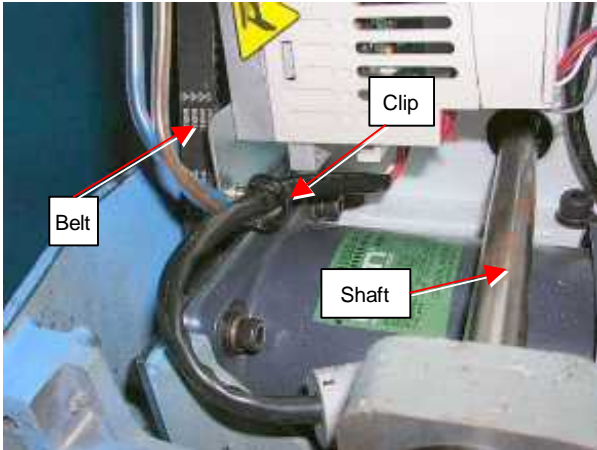

11. Fix Power cable by two Clamps.

<Note> Please bundle wires not brush any working parts

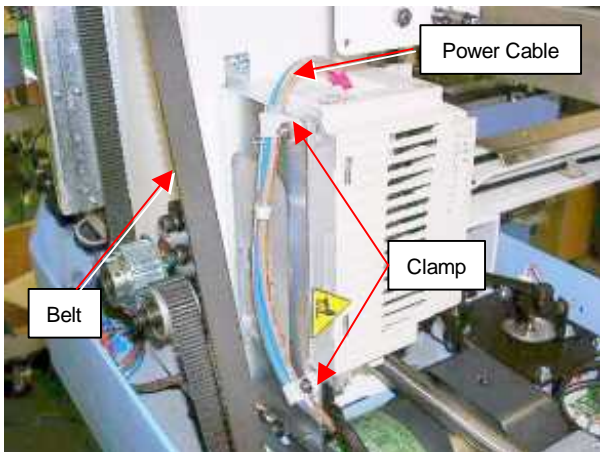

12. Please set machine speed by chapter [10-1 Adjustment of revolution].

End of process.

In case of spare parts supply, parameter is preset. Please contact HAPPY, when you need to change it.

Parameter cannot be set while machine is running . Pay attention to electric wires as setting is done with power is on.

\* Refer to [6-2-2] - [6-2-4] for 100V machine FR-S510W TYPE.

\* Refer to [6-2-5] - [6-2-8] for 200V machine VFNC1 TYPE.

**FR-S510W\*\*TY**

\* No use of VOLUME, RUN, STOP buttons.

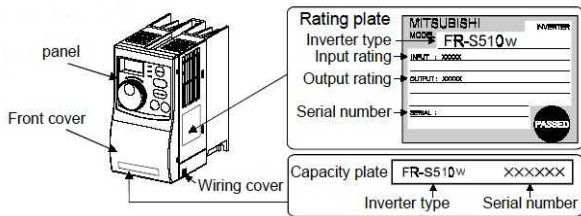

**VFNC1(S) TYPE**

\* No use of VOLUME, RUN, STOP buttons.

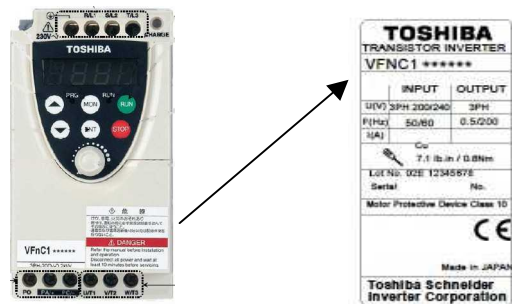

How to release prohibition of setting.

1. Press "Mode" button to display [P \*\*].

(3-time pressing enables you to go back to initial display)

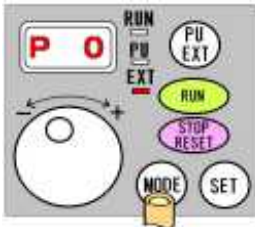

2. Rotate dial to have display [P 77].

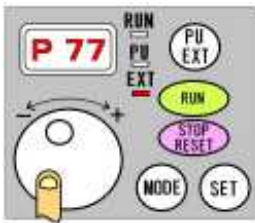

3. Press "SET" button to read preset value [1].

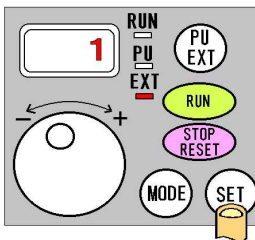

4. Rotate dial to have display [2].

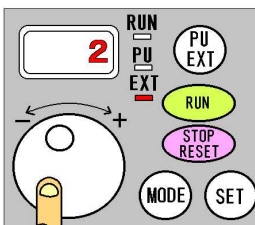

5. Press "SET" button to write preset value.

Alternate display will come during writing.

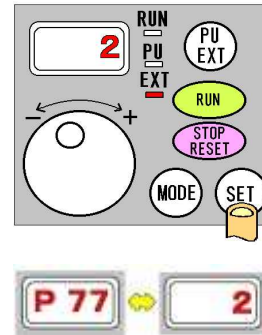

6. Setting other parameter is available.

After setting other parameters, return the setting [P 77] to have prohibition mode again.

7. Other parameter will be displayed by rotating dial.

Please note that parameter cannot be set while machine is running. Set parameter after releasing prohibition of parameter setting (Refer to 6-2-2). Refer to [11-4] for preset value. If you have done initialization of parameter FS-S510W, please set [P30=1] , [P79=2] , [P77=2] before setting other parameters.

1. Press "Mode" button to display [P \*\*].  
(3-time pressing enables you to go back to initial display)

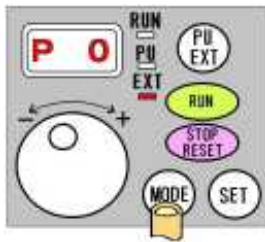

2. Rotate dial to have required display.

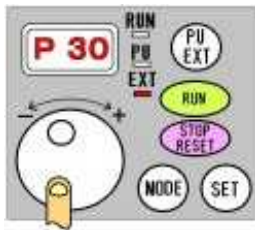

3. Press "SET" button to read preset value.

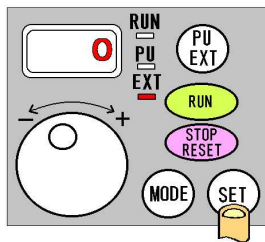

4. Rotate dial to select required preset value.

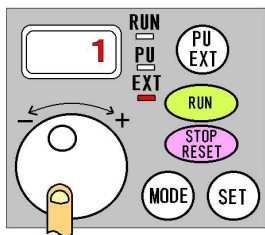

5. Press "SET" button to write preset value.  
Alternate display will come during writing.

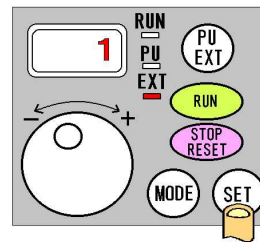

6. Rotate dial to have required display and repeat setting.

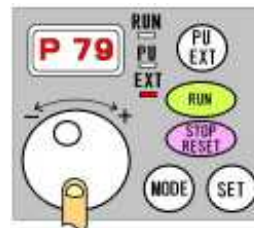

7. After setting all parameters, return it to prohibition mode by following procedure of [6-2-2 FR-S510W / Release of prohibition of parameter setting and its prohibition]."

Please note that parameter cannot be set while machine is running. Set parameter after releasing prohibition of parameter setting (Refer to 6-2-2).

In case of mis-setting, parameter can be reset at one time by initialization. Then change it to required parameter.

1. Press "Mode" button to display [P \*\*].  
(3-time pressing enables you to go back to initial display)

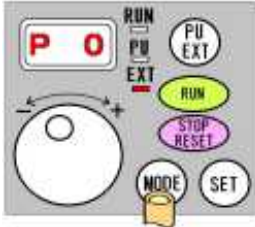

2. Rotate dial to have display [P 79].

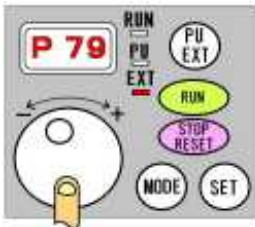

3. Press "SET" button to read preset value [2].

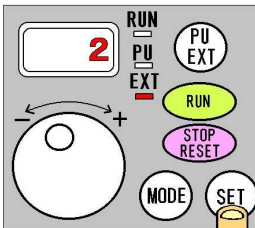

4. Rotate dial to have display [0].

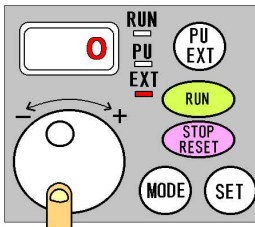

5. Press "SET" button to write preset value.

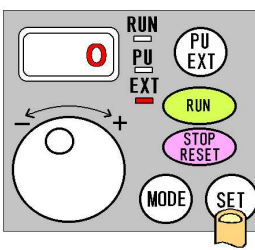

6. Rotate dial to have display [CLr].

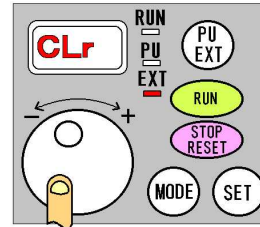

7. Press PU/EXT button and confirm PU lamp blinks.

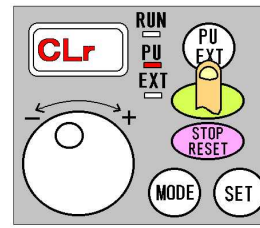

8. Press "SET" button to read preset value [0].

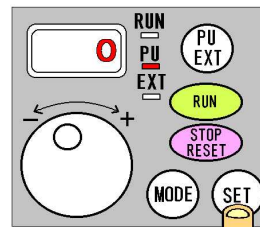

9. Rotate dial to have display [10].

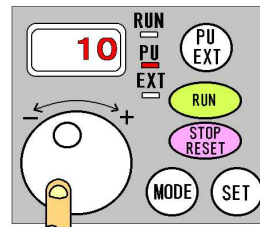

10. Press SET button to have alternate display of [10] and [CLr]. Then the initialization is completed.

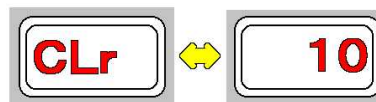

11. Refer to [6-2-3 FR-S510W / setting of parameter] to set parameter.

This is to release setting normally prohibited.

1. Press "MON" button to display AUH.

(When you press three times, display will make one round)



2. Press "▲▼" button to set to display of [F- - -].



3. Press "ENT" button to check display of [F100].



4. Press "▲▼" button to set to display of [F700].



5. Press "ENT" button to read number [1].



6. Press "▲▼" button to set to [0] and press ENT.



7. Now you can set other parameters.

Reference [11-5 VFNC1(S) type Inverter wiring and parameter setting ] After all paramaters seted, please set data [1] to paramater number [F700] for prohibits setting.

Please note that you are unable to make this setting while the machine is running.

Please set with prohibition of parameter setting released (reference to 6-2-5).

Basic parameter is to be set by setting items without F\*\*\*. Please refer to article 11-5 for setting value.

1. Press "MON" button to set to display of AUH.  
(When you press three times, display will make one round)



2. Press "▲▼" button to set to items you want to set.



3. Press "ENT" button to read setting value.



4. Press "▲▼" button to set to value you want to set.



5. Press "ENT" button to write setting value.



6. Press "▲▼" button to set to items you want to set.

Repeat settings.

7. After setting, please set to prohibition of setting in accordance with [6-2-5 VFNC1(S) / Release of prohibition of parameter setting and its prohibition].

## VFNC1(S) Setting extension parameter

6-2-7

Please note that you are unable to make this setting while the machine is running.

Please set with prohibition of parameter setting released (reference to 6-2-5).

Expansion parameter is to be set by setting items with F\*\*\*. Please refer to article [11-5 for setting value].

1. Press "MON" button to set to display of AUH.  
(When you press three times, display will make one round)



2. Press "▲▼" button to set to display of [F- - -].



3. Press "ENT" button to check display of [F100].



4. Press "▲▼" button to set to display of item you want to set.



5. Press "ENT" button to read setting value.



6. Press "▲▼" button to set to value you want to set.



7. Press "ENT" button to write setting value.



8. Press "▲▼" button to set to items you want to set and press "ENT" button to set other items.

9. After setting, please set to prohibition of setting in accordance with [6-2-5 VFNC1(S) / Release of prohibition of parameter setting and its prohibition].

# VNC1(S) Initialize parameters.

Please note that you are unable to make this setting while the machine is running.

Please set with prohibition of parameter setting released (reference to 6-2-5).

When setting is mistakenly made in mid way, the setting will return to parameter in normal standard in one action.

Thereafter please change to parameter you want to set.

1. Press "MON" button to set to display of AUH.  
(When you press three times, display will make one round)



2. Press "▲▼" button to set to display of EYP .



3. Press" ENT" button to check display of [3\_\_0].



4. Press "▲▼" button to set to display of [3\_\_3].



5. Press "ENT" button to display [InL], then set it back to[0.0].  
You will get initialization finished.



6. Please set basic parameter and expansion parameter.

## 7 Installment and setting of option unit

7-1 Installment of floppy disk drive unit

7-2 Installment of extended memory board

7-3 Installment, setting and adjustment of needle sensor

7-3-1 Installment of fix needle sensor

7-3-2 Setting procedure

7-3-3 Adjustment of optical axis

7-4 Installment of Bobbin winder

1. Fix floppy disk drive unit. Remove outer cover (right), referring to [ 2-2 How to remove outer cover ]  
Check the parts showed as bellow.

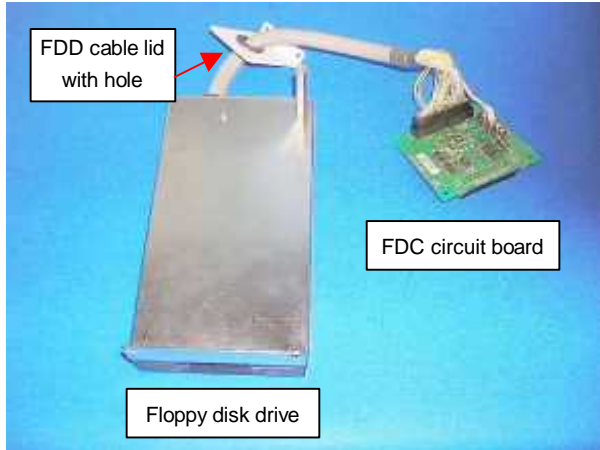

2. Take out FDD panel ( without hole ) mounted on the machine body.

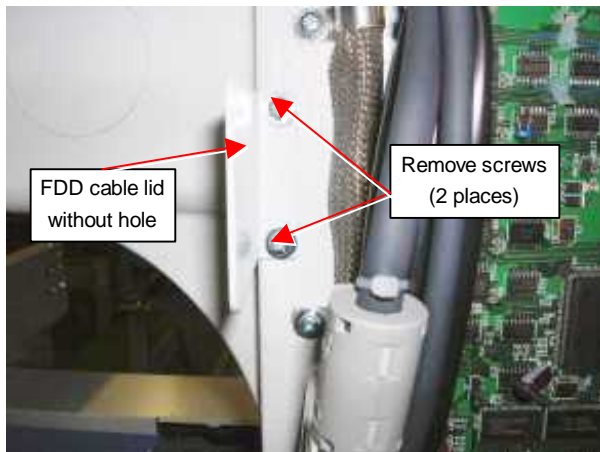

3. Fix floppy disk drive to arm located at right side of control box.

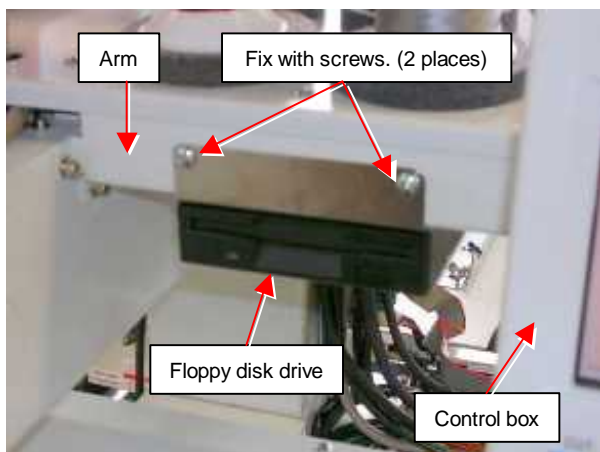

4. Fix stat bolt located at back of floppy disk drive to thread stand.

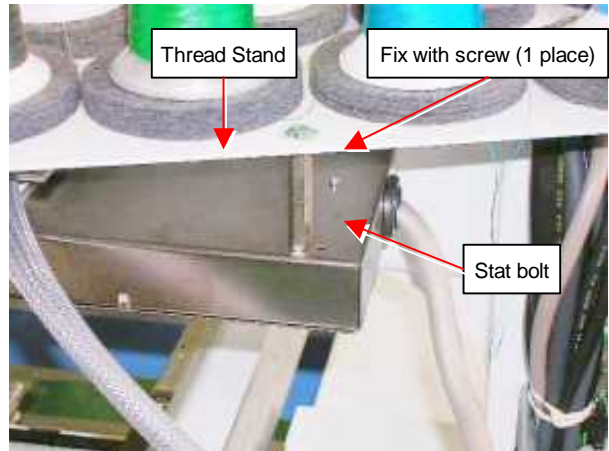

5. Fix FDC circuit board to CPU circuit board.

<NOTE>

Make sure that wires is not jammed by FDC circuit board.

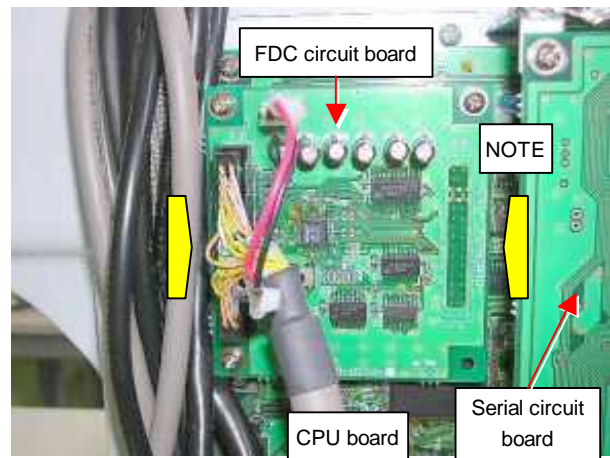

6. Fix FDC circuit board with screws.

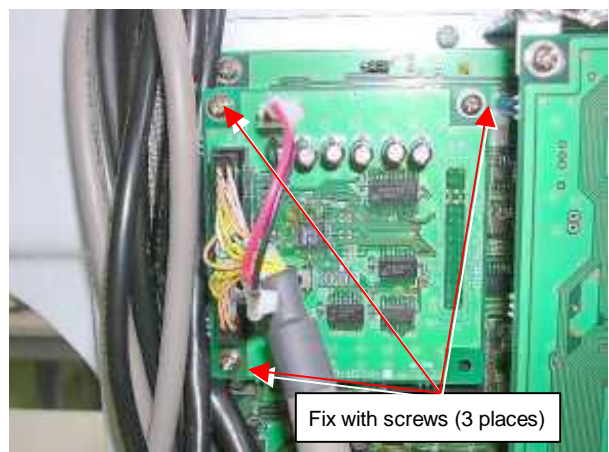

7. Fix FDD panel (with hole) to machine body.

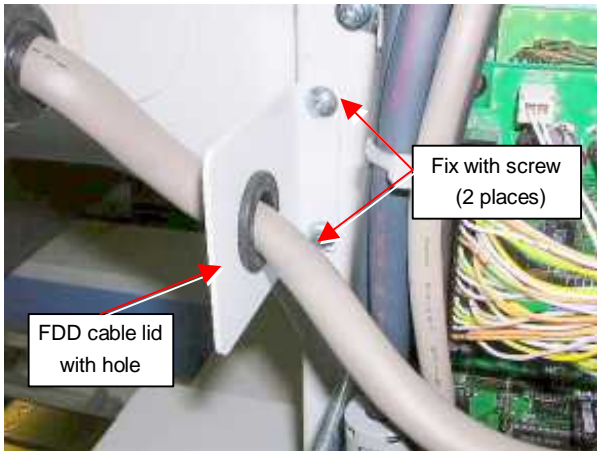

8. Put back outer cover (right).

<Note>

Make sure that wires are not jammed.

End of process

\* When you start machine again, the below display shows up by [READ] command. The pattern data of various format can be read and written by machine.

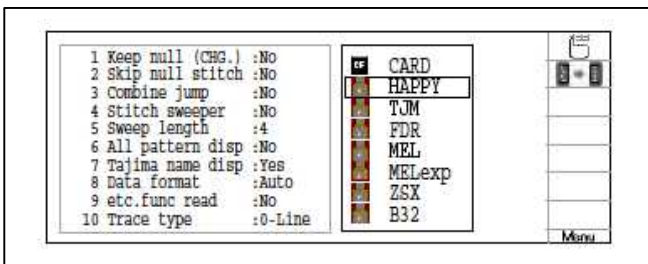

### 1. Fix extended memory.

Remove outer cover (right), referring to [ 2-2 How to remove outer cover ]

The bellow picture is an extended memory board.

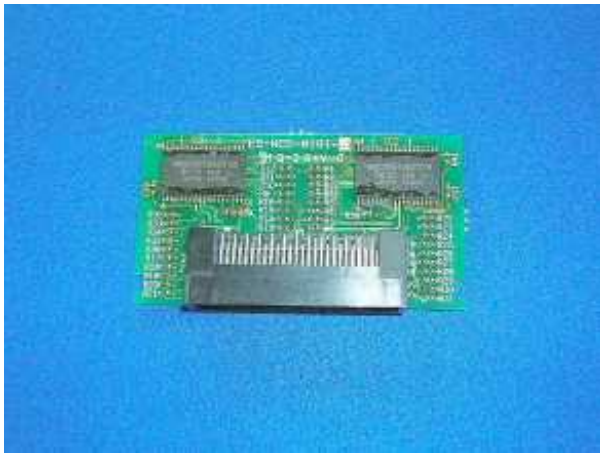

\* This extended memory board adds 500,000 stitches per board in memory.

\* Maximum 2 board (1 million stitches) can be add.

### 2. Fix an extended memory board to CPU board.

Regarding the location where it is fixed, please refer to the bellow.

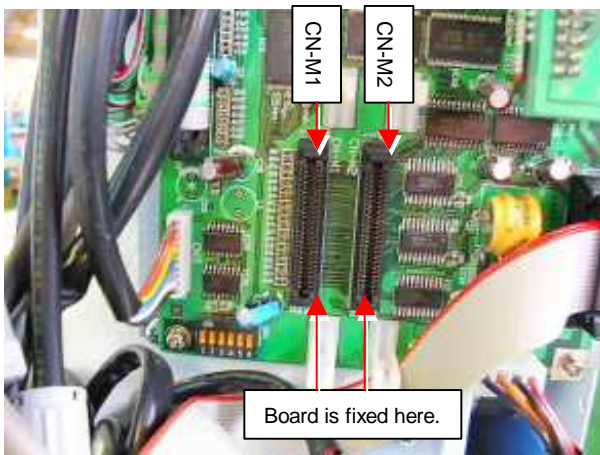

#### <Note>

In case that only one extended memory board is fit, use CN-M1 connector.

(Otherwise, the extended memory cannot be recognized.)

### 3. Insert an extended memory board to CPU board, so that connector of extended memory is left side as showed bellow. (If the direction is wrong, it cannot be inserted.)

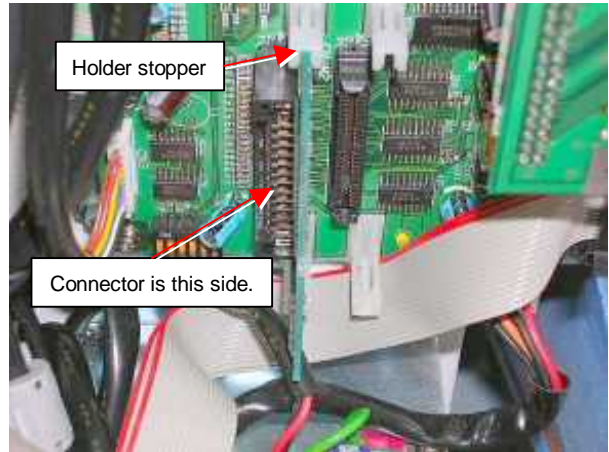

Insert it until you hear the holder stopper click.

### 4. The bellow picture shows that 2 extended memory boards are fixed.



### 5. Restoer outer cover right.

### 6. If extended memory board is fixed, during reading pattern data, display of free space of memory will be increased.

Id : 04 Free:1447168

End of process

\* Remove outer cover (right), referring to [ 2-2 How to remove outer cover ]

\* Remove the thread on thread stand before this work.

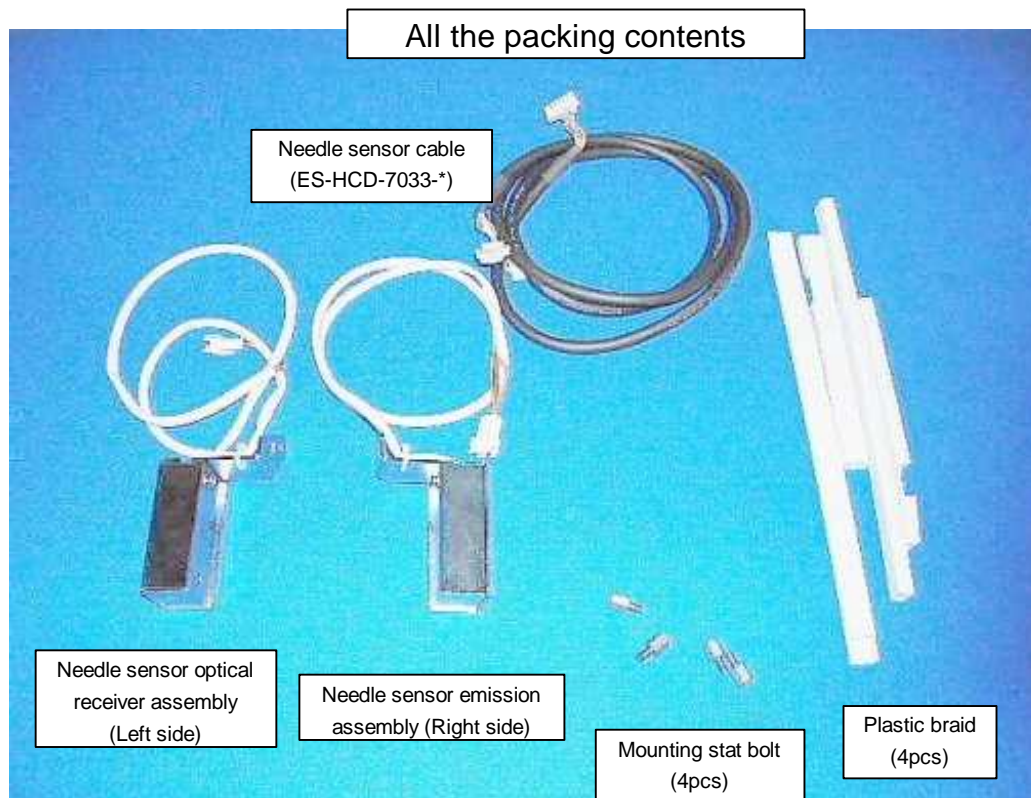

## Installment of needle sensor

7-3-1

1. Take out thread guide bracket.

Remove screws by hexagonal wrench. (2 places as showed bellow)

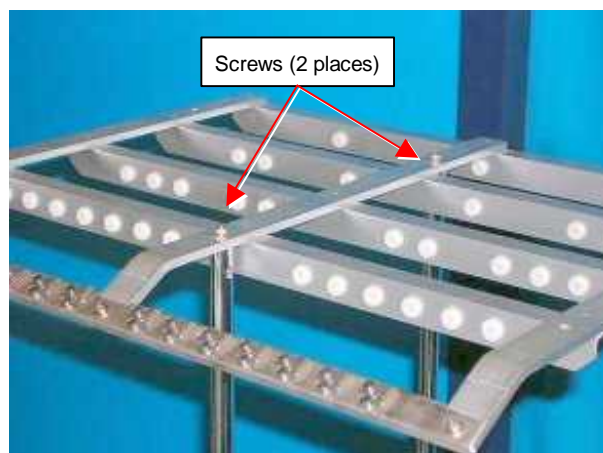

2. Take out thread guide pillars.

Referring to the bellow, insert a hexagonal wrench to the hall, turn thread guide pillars and take out them. (2pcs)

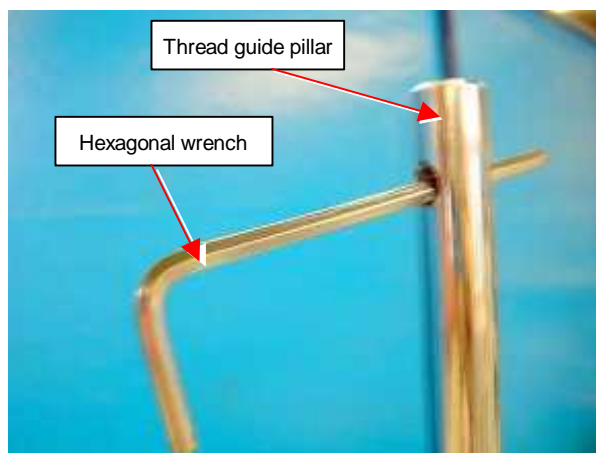

3. Take out thread stand.

Remove screws (8 places or 9 places in case of floppy disk drive fixed) as showed bellow.

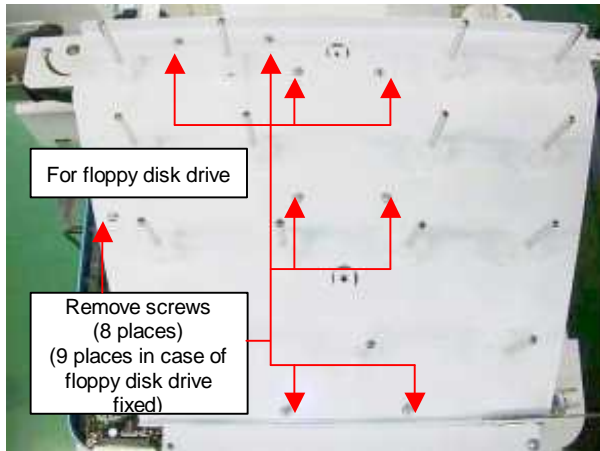

4. Take out upper cover of arm.

Remove screws (2 places as bellow) and take out upper cover of arm.

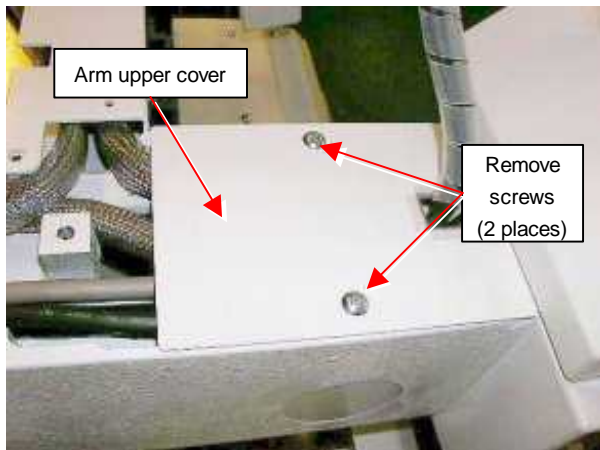

5. Take out TC cover. Remove screws (6 places as bellow)

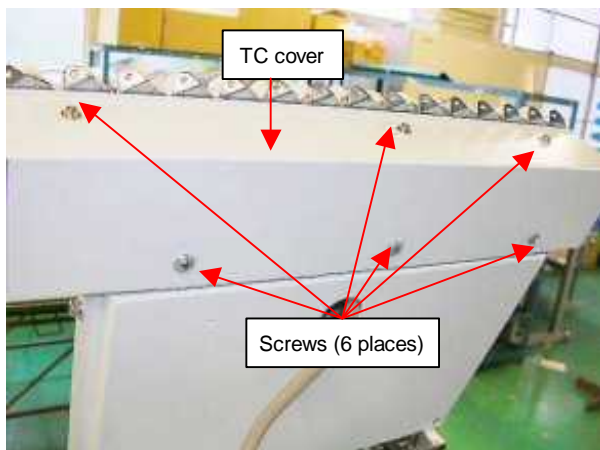

6. Plug off TC cable of TC15 board connector (CN3).

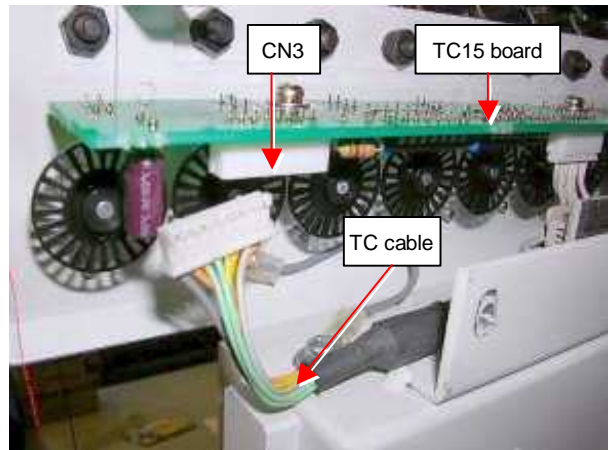

7. Pull out TC cable plugged off at step 6 and remove spiral tube.

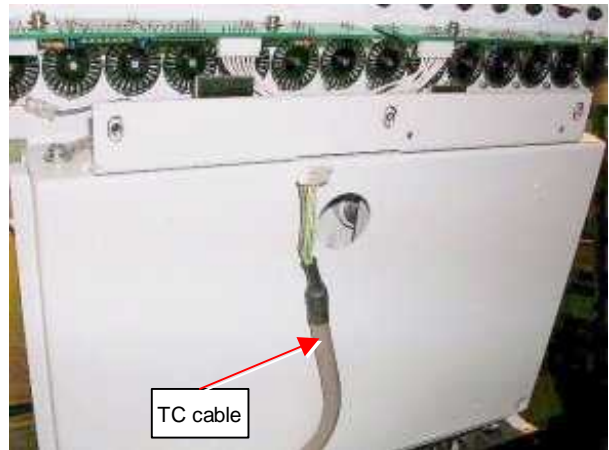

8. Fix Needle sensor cable to drive board connector (CN29).

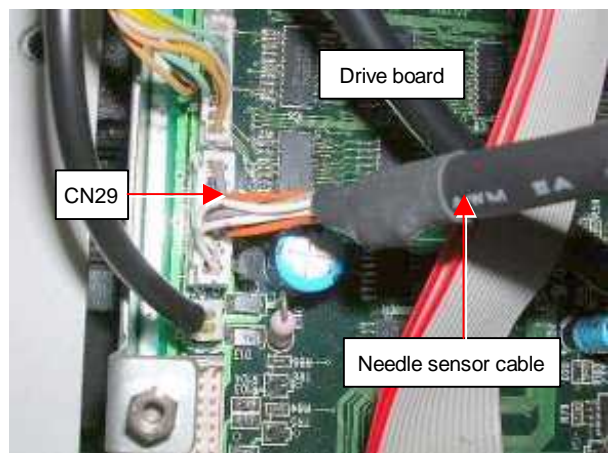

9. Cover needle sensor cable and TC cable together by spiral tube.

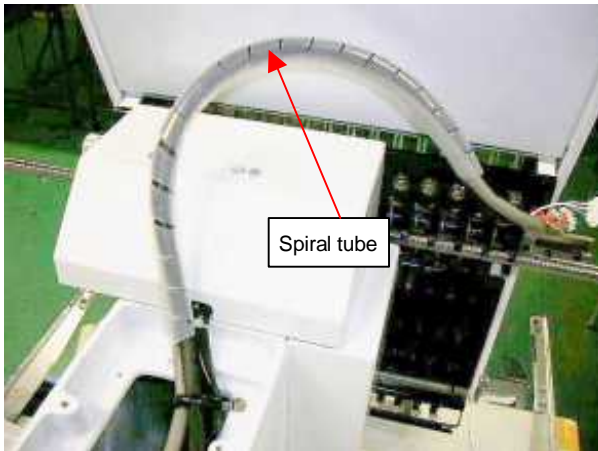

10. Insert both TC cable and Needle sensor cable covered by spiral tube into thread tension portion.

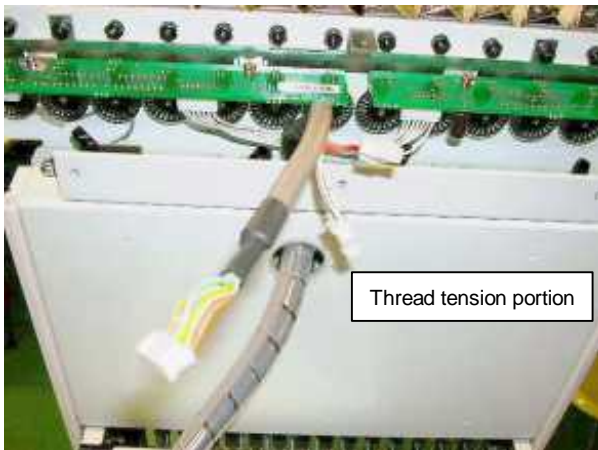

11. Plug TC cable into TC15 board connector (CN3).

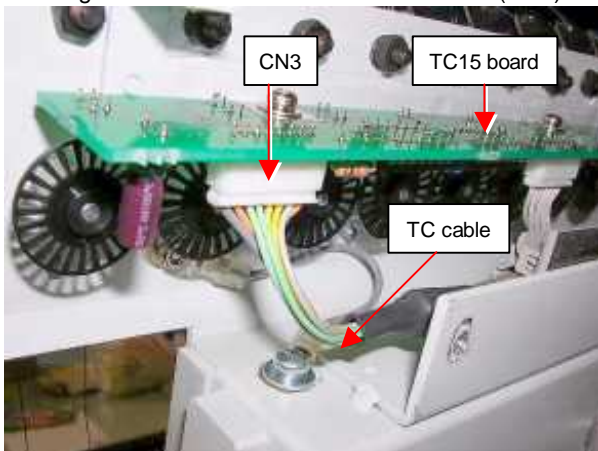

12. Move to Needle number 15 and allow length of TC cable/ Needle sensor cable.



13. Wire needle sensor cable at upper portion of arm as bellow.

Fix needle sensor with guide clips (3 places)

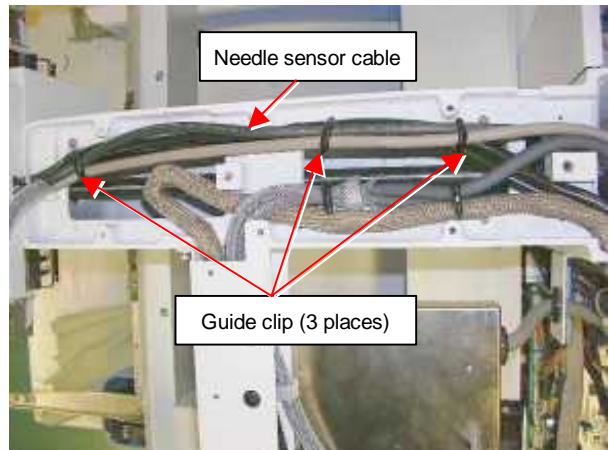

14. Fix needle sensor cable near needle bar change portion with a guide clip as bellow.

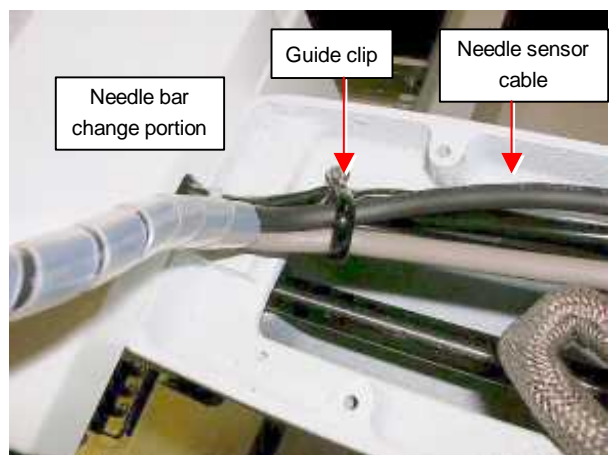

# Installment of needle sensor

15. Put plastic braid on right and left on the moving head.

<Note> Plastic braids have 2 types (long and short). Put short one at lower side and long one at upper side.

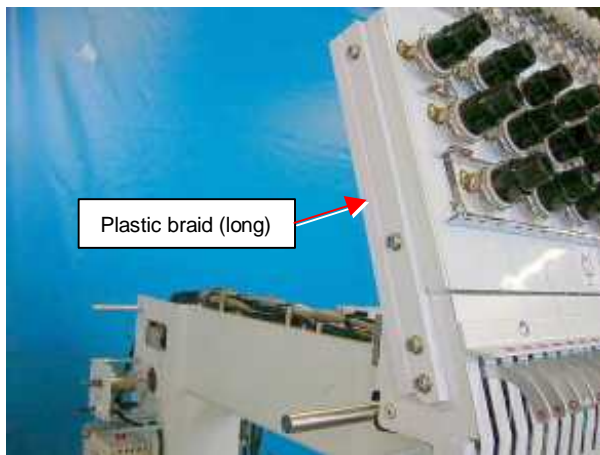

16. Remove holder-mounting screws.

Remove the mounting screws (2 places per side)

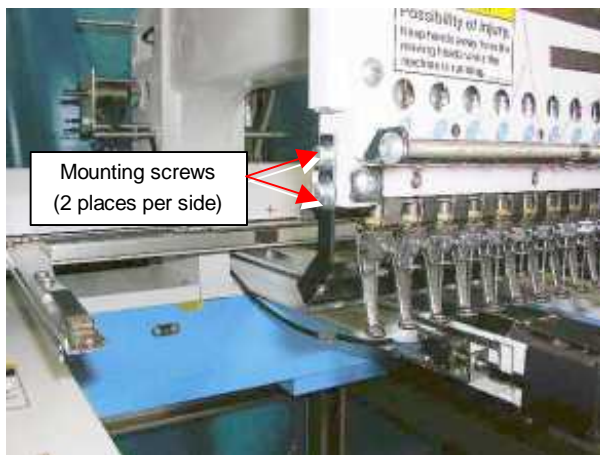

<NOTE>

Procedure 16 and 17 should be done separately either left or right side. Adjustment of Holder position will be needed if you do both side at once.

17. Fix stat bolts to the place where the screws are removed at step 15 (Holder mounting portion) for both sides.

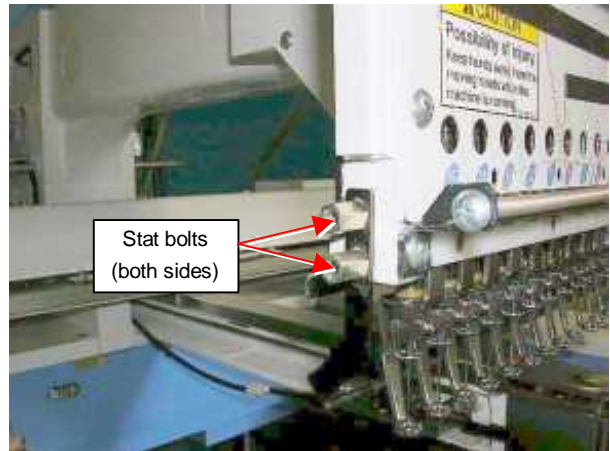

18. Fix needle sensor to the stat bolts.

Needle sensor optical receiver is fixed at left side.

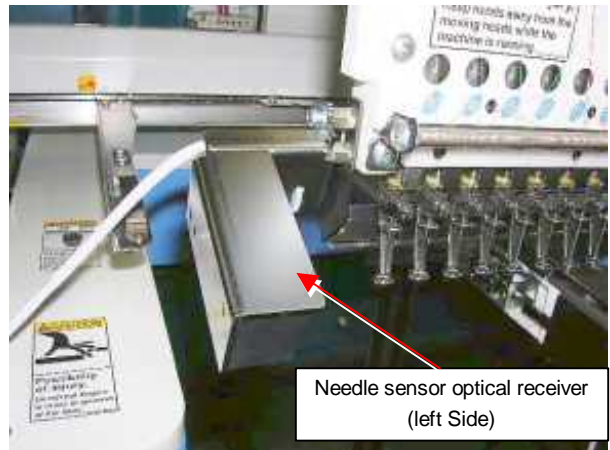

19. Install Needle sensor at Stud.

Needle sensor emission assembly will be installed at Right side.

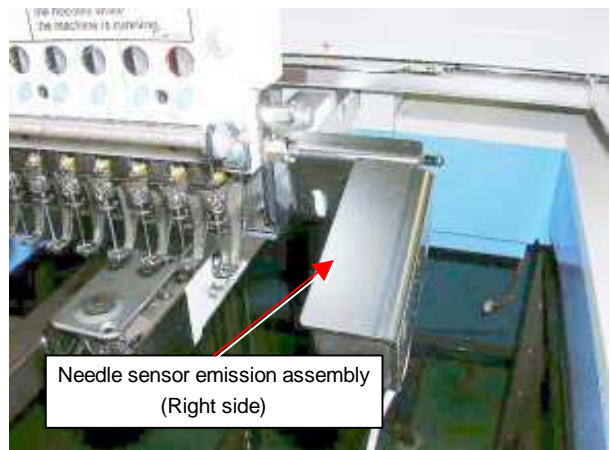

20. Put Needle sensor cable through into Plastic braid (white).  
(Both Right and Left)

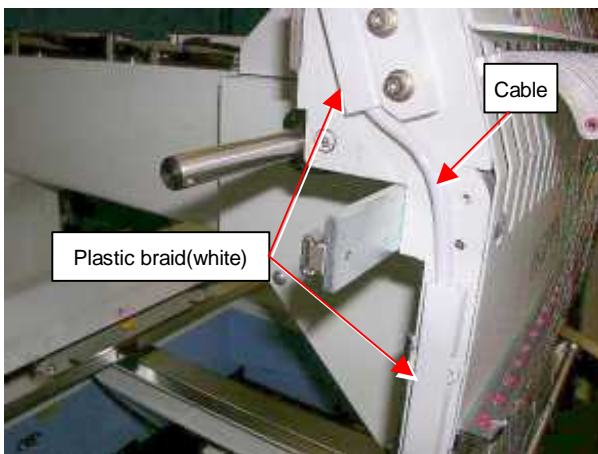
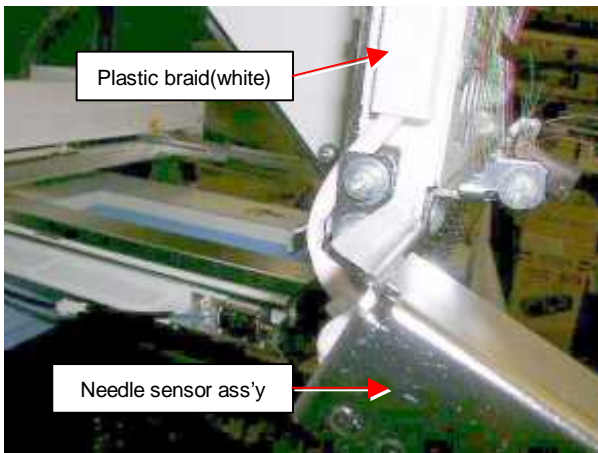

22. Connect Needle sensor cable and Needle sensor assembly in the TC device.(Right and Left)

\* Needle sensor emission side(Right side) will be connected with 3P connector, Needle sensor optical receiver side (Left side) will be connected with 4P connector.

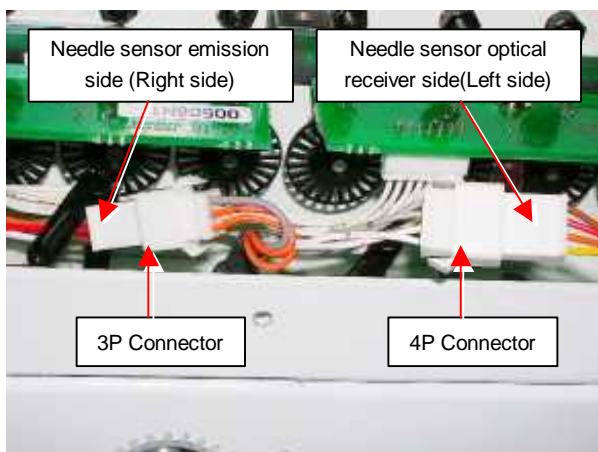

22. Fix Harness with Coating clip(4 place)

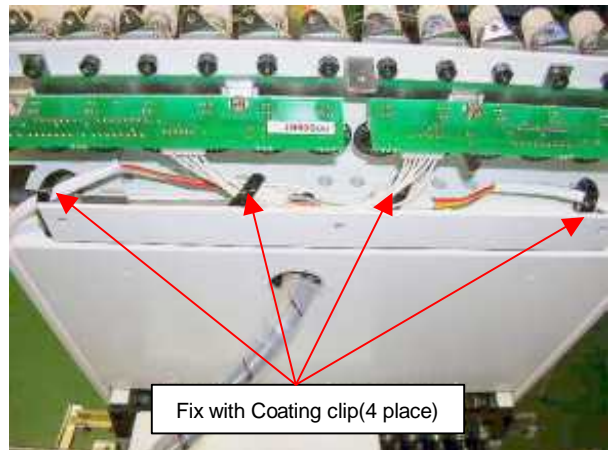

<Note> Tie up the Harness in order not to interfere with Detecting slit disk.

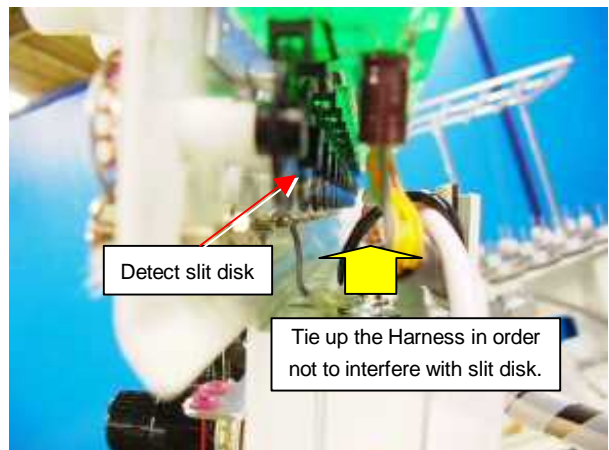

23. Replace all the removed parts like covers and procedure is finished.

\* Confirm adjustment of Holder by referring to [ 3-3-10 Adjustment of clearance of Holder ]

End of process

1. Go to maintenance mode. Refer to [ 9-1 How to enter maintenance mode ]

2. Move cursor with  button and press **[SET]** button at [ Setup ]

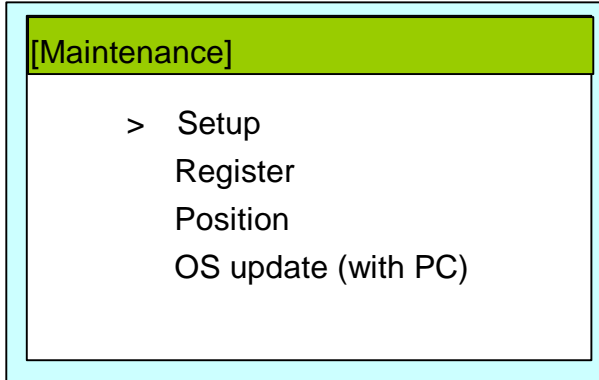

3. Turn over with  until below (page 5) will display.

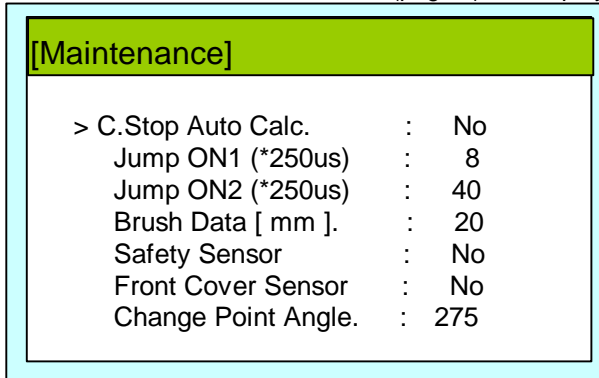

4. Move cursor with  button and change setting into [N.Safety Sensor : **Yes**] from [N.Safety Sensor : No ]

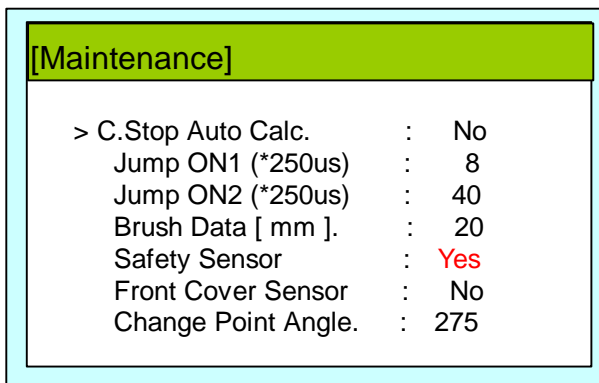

5. Press **[ESC]** button and below will be displayed

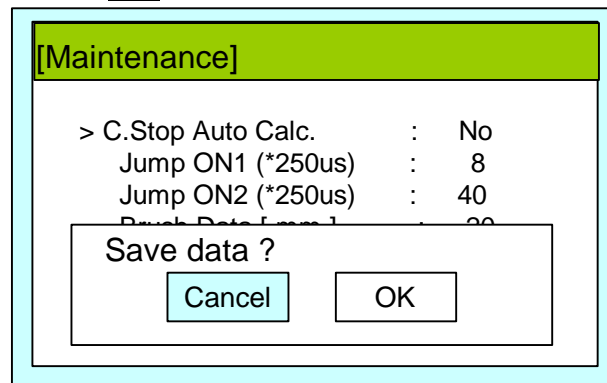

6. Move cursor with  button and press **[SET]** button at [ OK ].

Below will be displayed and returns to [procedure 2] after rewrite of System data.

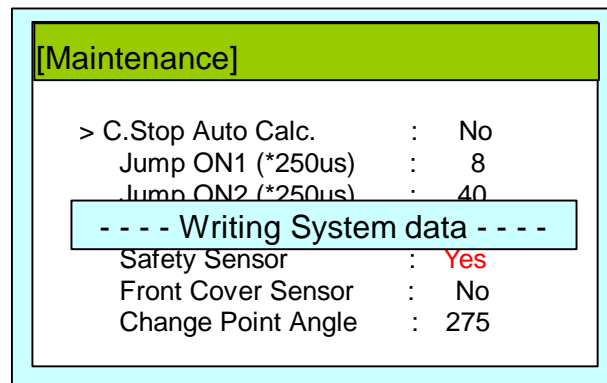

7. Return to drive mode by press **[ESC]** button.

\* Needle sensor setting procedure is done.

1. Install Needle sensor emission assembly (Right side) at correct position.



2. Loosen screws that are fixing Needle sensor optical receiver assembly (left side)

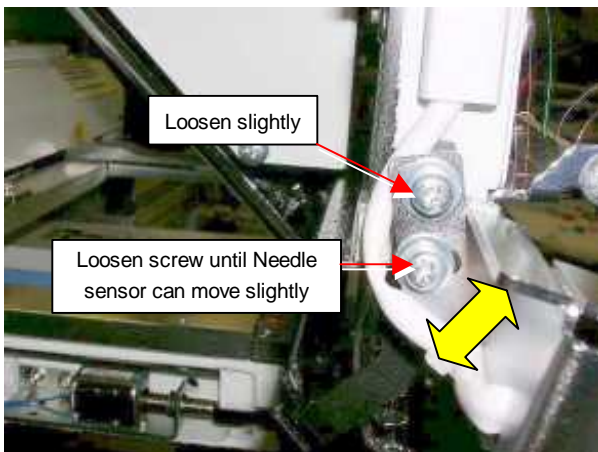

3. Move Needle sensor optical receiver side(Left side) up and down and fix it where LED lamp lights strongly.

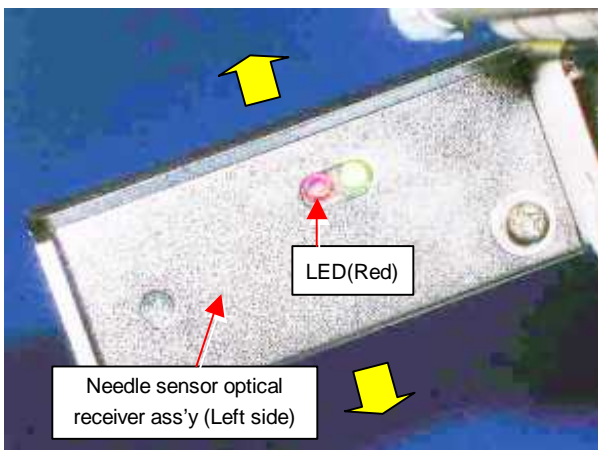

4. Confirm of operation check.

Block Optical axis of Needle sensor at drive mode(Use screwdriver or something)



5. Press **Start** button.

Below error will be displayed and Machine won't start if Needle sensor works properly.

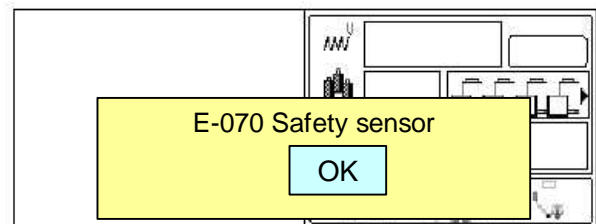

\* Adjustment of Optical axis is done.

\*. Install Bobbin winder

Remove outer cover left. Refer to [ 2-2 How to remove Outer cover left ]

\* Confirm all the necessary items are ready.

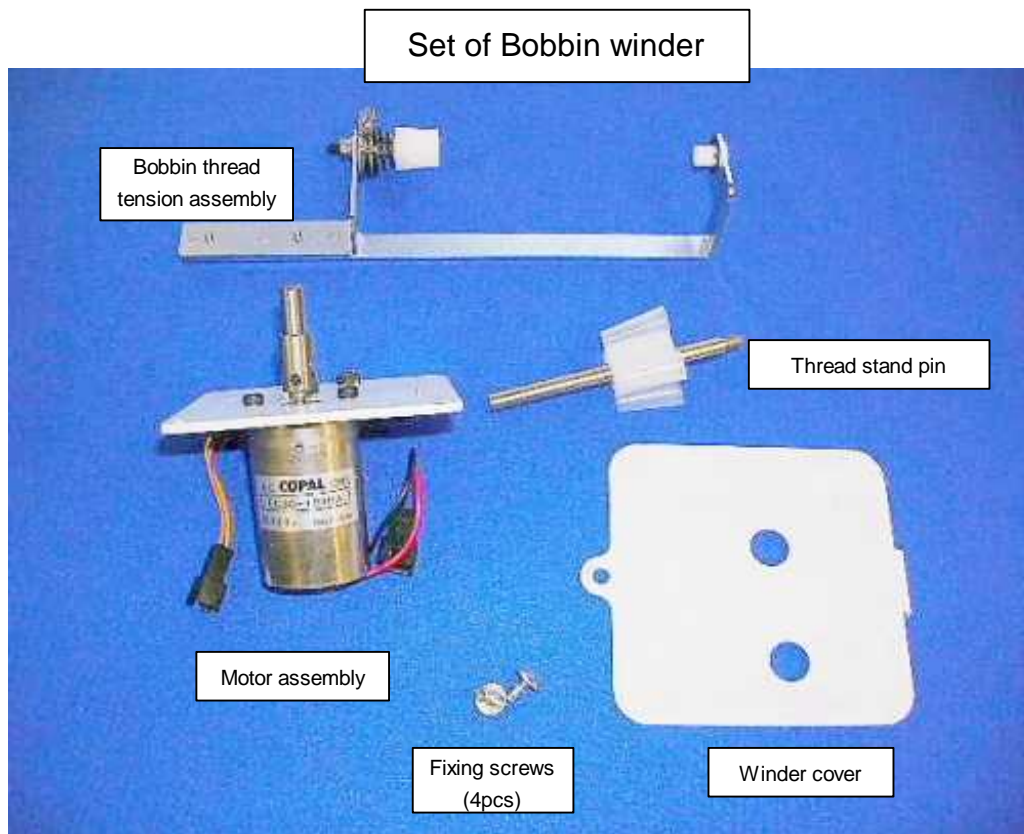

1. Remove Guide from Bobbin thread winding motor assembly. Remove with hexagonal wrench. (In order to avoid interference at the time of installation of cover.)

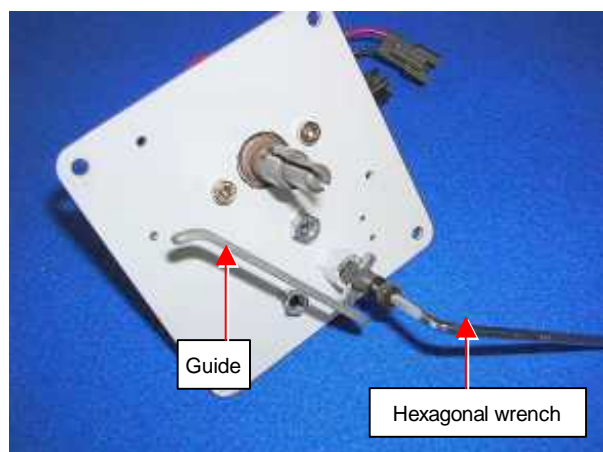

2. Install Bobbin thread motor assembly as the picture below with attached screws.

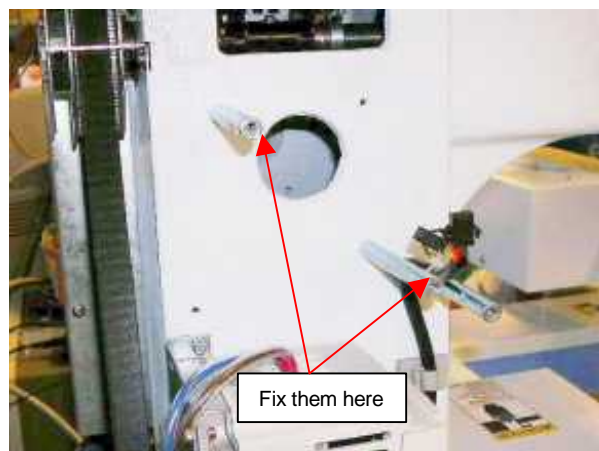

3. After installment

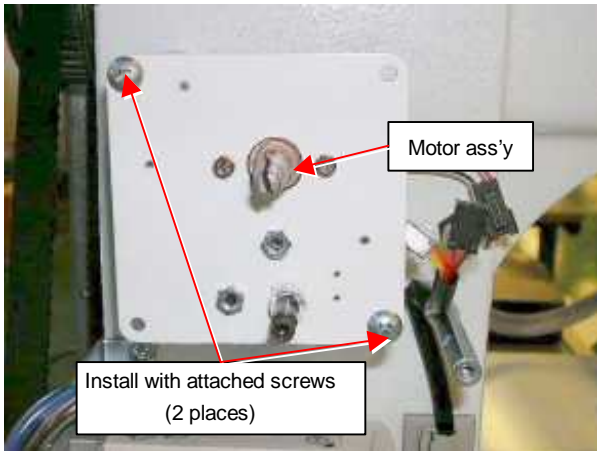

- \* Make sure with mounting direction
- \* Motor has to come upper position.

4. Connect DC motor relay cable from Arm body and 2P connector (Limit switch cable) from Bobbin thread winder assembly.

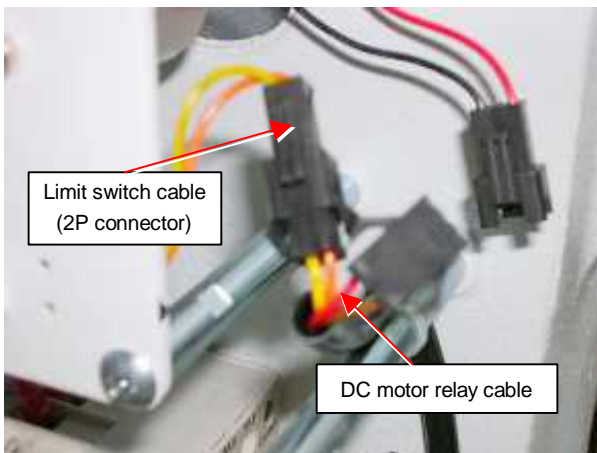

5. Connect 3P connector (DC motor relay cable) from Arm body and 3P connector (DC motor cable) from Bobbin thread winder assembly.

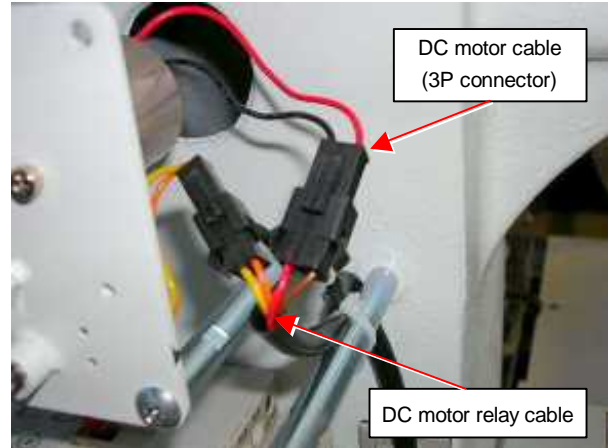

6. Remove Cover J from Cover B

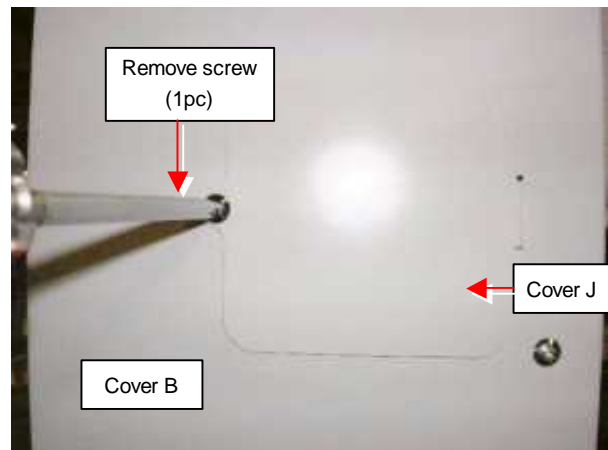

7. Install Cover B to Body.

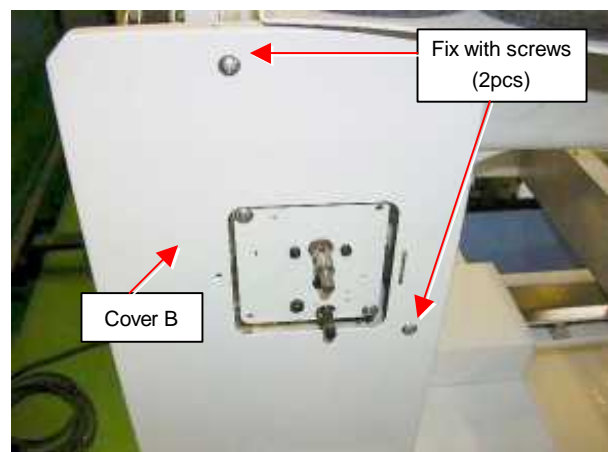

8. Install Cover B with screws.

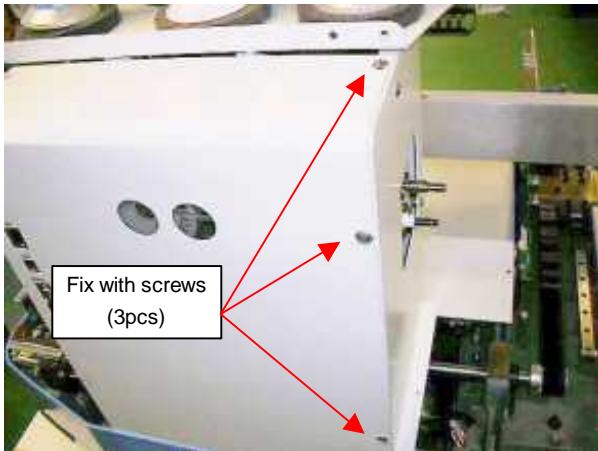

9. Remove screw from Cover D and Install Thread stand pin to Cover D.

Use Flat head screwdriver.

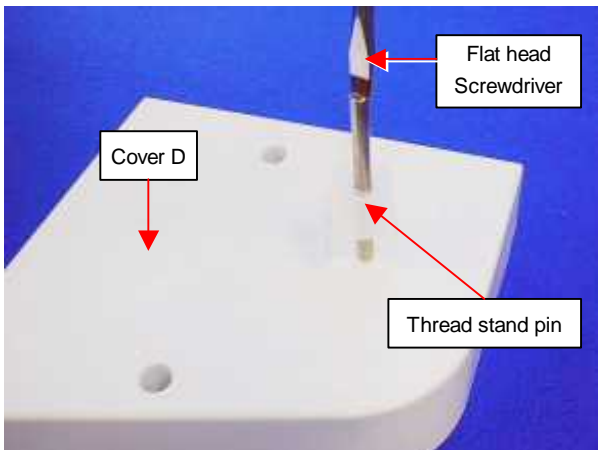

10. Install Cover D on to the Machine body.

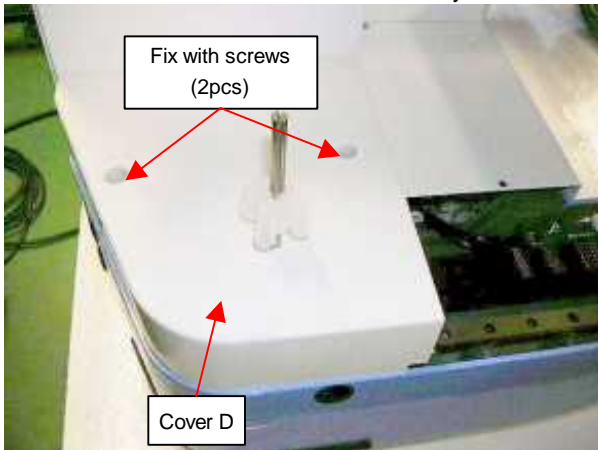

11. Install Bobbin thread tension assembly to Thread stand as the picture below.

( Before installment )

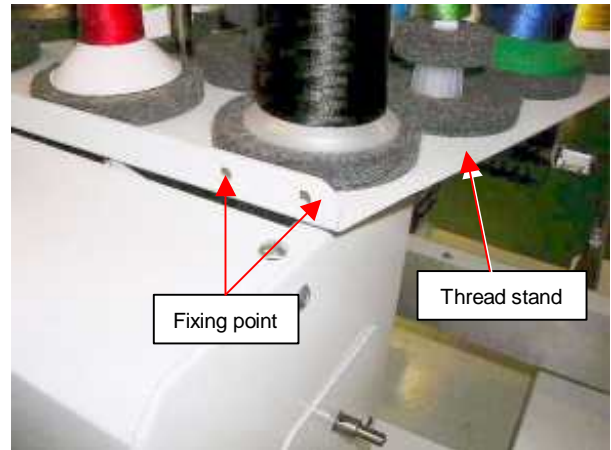

(After installment)

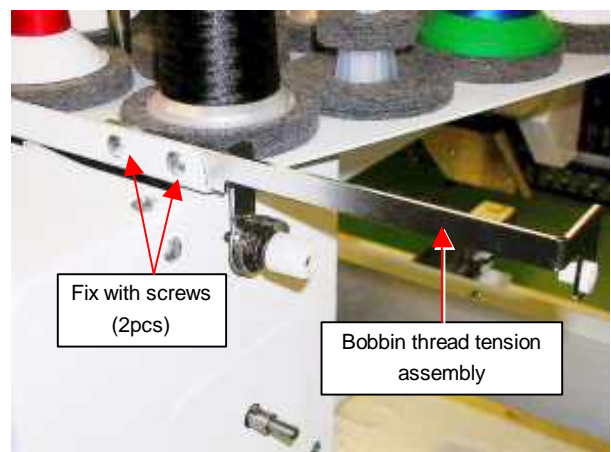

12. Reinstall Guide which has been removed at procedure 1.

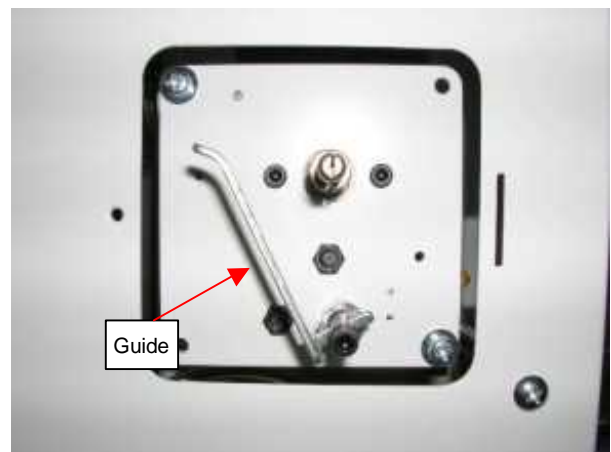

13. Adjust position of Guide.

Put Empty bobbin into Thread winding shaft and adjust position of Guide to be center of Empty bobbin.

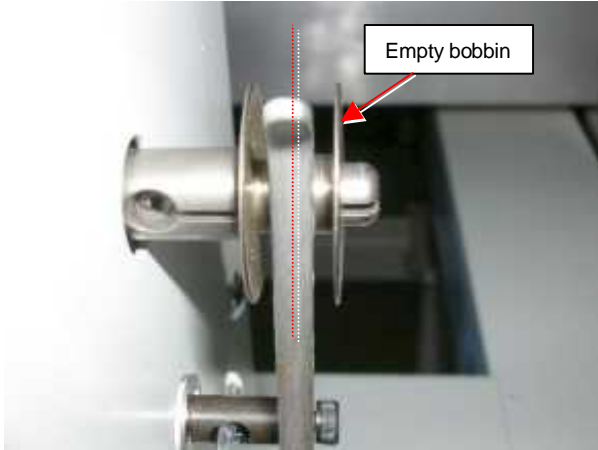

\* Loosen screw(2pcs) of Thread winding shaft and adjust position by moving backward or forward.

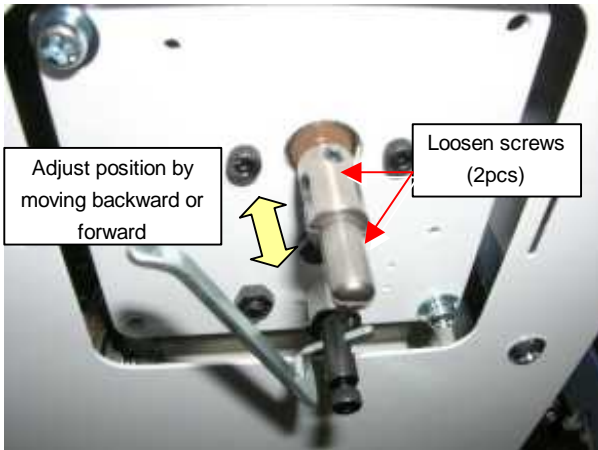

14. Wind the bobbin thread. Put the thread through as below.



\* Check thread winds up properly by adjusting position of procedure 13.

15. Remove Guide and install attached Winder cover to Cover B.

<Note> Clearance around shaft should be kept averagely.

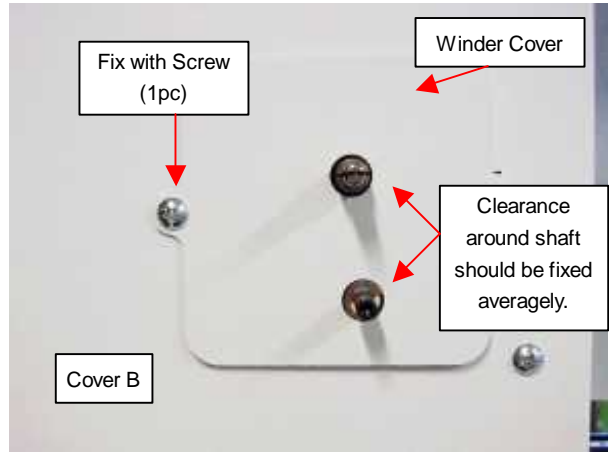

16. Install Guide which has been removed on procedure 15



17. Wind the bobbin thread.

Adjust Position of Guide to adjust volume of thread to be wound.

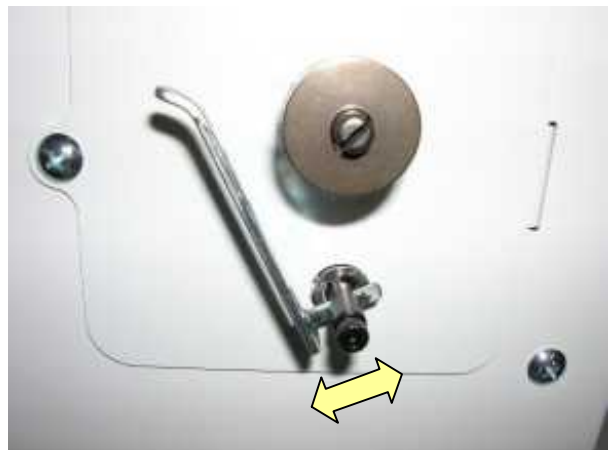

Installment of Bobbin thread winder is finished.

## 8 Initialization of system

8-1 Notice for update and Initialize machine systems

8-2 Operation order for update and Initialize machine systems

8-3 Detail operation order for update machine systems

8-3-1 How to Update Program for Control of ATA LCD Board

8-3-2 How to Change Language Setting

8-3-3 How to Update CPU Board Program

8-3-4 How to Update Data for Frame Driving

8-4 Initialization of memory

8-4-1 Initialization ATA LCD board memory

8-4-2 Initialization CPU board memory

Rewriting of program is required for version up of control program, replacement of CPU board and ATA LCD boards or change of language setting

\* Contents of system program for HCD are as follows.

### CPU Board

OS : HCDH\*\*\*\* ( program for control of CPU board )  
Drive : CD1A ( data for frame driving )

### LCD Board

Control : LCDH\*\*\*\* ( program for control of LCD board )  
Language : H\_ENG\*\*\* ( English )  
          : H\_JPN\*\*\* ( Japanese )

\* System program above will be shown as below on PC screen.

Program for control of CPU board	: HCDH****——HCDH****.upi + HCDH****.bin	: 2 files required
Data for frame driving	: CD1A***——CD1A***.upi + CD1A***.bin	: 2 files required
Program for control of LCD board	: LCDH****——LCDH****.upi + LCDH****.bin	: 2 files required
Language (English and others)	: H_ENG***——H_ENG***.upi + H_ENG***.bin	: 2 files required

### <NOTE 1>

Please do not write system program in folder in CF card (FD) when you upgrade machine by writing system program in CF card (FD) by PC as machine becomes unable to recognize version up program (please write system program on route of subject media).

### <NOTE 2>

When you upgrade program with Floppy Disk Drive, please proceed without CF card inserted.  
Upgrading is not available when you upgrade program with CF card inserted as priority is given to CF card.

\* In case, upgrade plural programs same time, please keep following priority install order.

1. LCDH\*\*\*\* ( Program for control of LCD board )
2. H\_ENG\*\*\* or H\_JPN\*\*\* or H\_GER\*\*\* or H\_DAN\*\*\* etc.... ( Language )
3. HCDH\*\*\*\* ( Program for control of CPU board )
4. CD1A\*\* ( Data for frame driving )

### <NOTE 3>

\* After replace board and upgrade program, please operate following items.

1. After upgrade LCD board program (Control and Language), please operate chapter [8-4-1 Initialization ATA LCD board memory LCD] for clear a memory.
2. After upgrading CPU board control program, please proceed with Initialization of system and Automatic speed setting with reference to “25-1.2 Initialization of machine” in Instruction Book of separate volume.
3. In case of replacement of CPU board, please make correct Clock Setting with reference to “13-7 Registration of coordinates” and “3-7 DATE/ TIME” in Instruction Book of separate volume.

\* Work sequence of Updating Program are described below.

If you need more detail information fro each sequence, please reference each manual

- |   |   |   |
|---|---|---|
| 1. Insert CF card ( FD ) saved update program to slot of control panel.<br>Press and keep [ MENU ] button and turn on the machine | } | Maintenance Manual<br>8-3 Detail operation<br>order for update<br>machine systems           |
| 2. In Maintenance Mode, Installation of each data for upgrading and change of language data are available.                        |   |   |
| 3. [Update LCD board control program]<br>Flip dipswitch [DSW1 to ON] on ATA LCD board. And turn on machine.Starts initialize      | } | Maintenance Manual<br>8-4 Initialization of memory  |
| 4. [Update LCD board control program]<br>Turn off machine power And Flip back dipswitch [DSW1 to OFF].                            |   |   |
| 5. [Replacement of CPU board]<br>Register frame position in Maintenance Mode.   | } | Maintenance Manual<br>9-7 Position—Registration<br>of coordinates for<br>positioning sensor |
| 6. Press [MENU] button and select [System] in menu of [OTHER] for initialization of system.                                       | } | Instruction book<br>25-1.2 Initialize machine   |
| 7. Press [MENU] button and select [Speed] in menu of [OTHER] for automatic speed setting.   |   |   |
| 8. [Replacement of CPU board]<br>Calender setting   | } | Instruction book<br>3-7 Calendar setting  |
| 9. end of process   |   |   |

1. Update of ATA LCD board program

Insert CF card contains data for version up into CF card insertion slot (FD Drive is for use of Floppy Disk).



2. Refer to [ 9-1 How to enter maintenance mode ] and enter maintenance mode. Display comes as below.

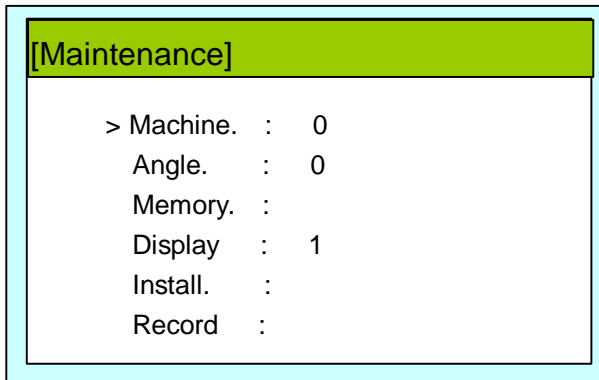

3. Place cursor at [ Install ] by button and press **SET** button.

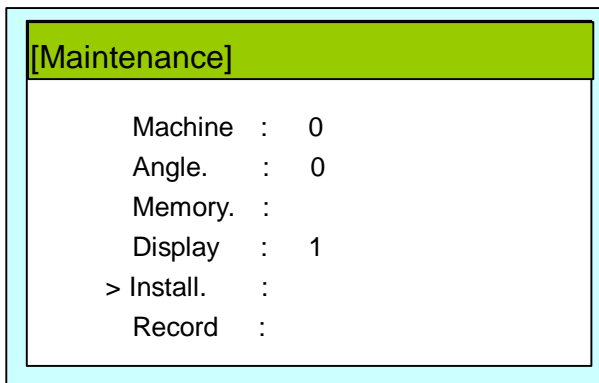

4. Display comes as below after reading data in PC card or Floppy Disk.

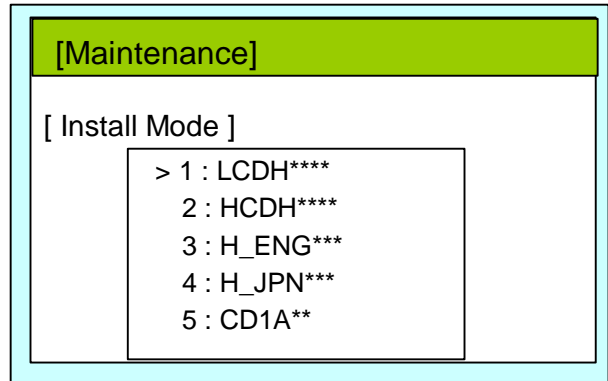

5. Place cursor at [LCDH\*\*\*\*] by button and press **SET** button. Installation of program for control of LCD board begins. Display comes as below.

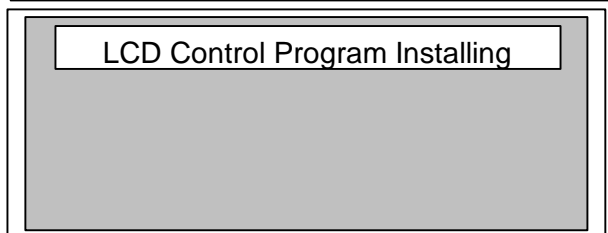
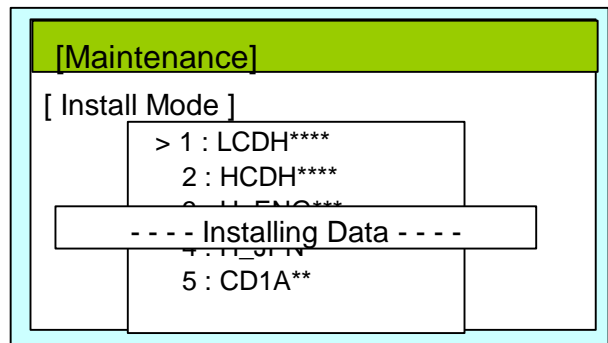

<NOTE>

- 1. Please do not take out CF card (Floppy Disk) during installation
- 2. Please do not turn off the power during installation (it will take for a while for completion of installation).

Reactivation is done automatically.





- \* Press **SET** button.
- \* End of process.

1. Change language of LCD panel

Insert CF card contains data for version up into CF card insertion slot.(FD Drive is for use of Floppy Disk).

2. Refer to [ 9-1 How to enter maintenance mode ] and enter maintenance mode.

3. Place cursor at [ Install ] by  button and press **SET** button.

4. Select language display program required for installation by  button. Installation of language display starts by pressing **SET** button.

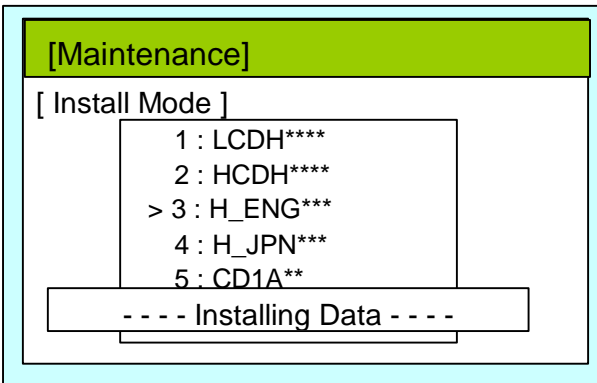

\* Language data are as follows:

- English    H\_ENG\*\*\*
- Japanese   H\_JPN\*\*\*
- German.    H\_GER\*\*\*
- Danish.    H\_DAN\*\*\*

<NOTE>

1. Please do not take out CF card (Floppy Disk) during installation.
2. Please do not turn off the power during installation (it will take for a while for completion of installation).

5. Message below will be shown after proper completion.

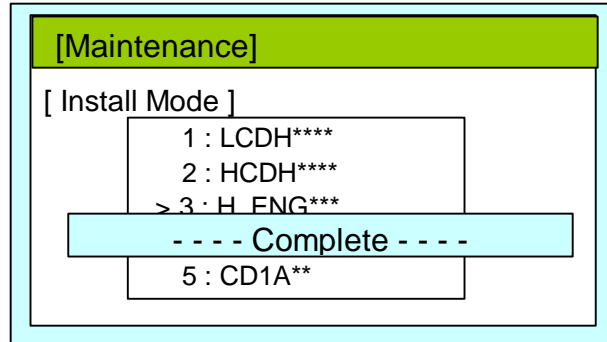

6. Only a short while later, maintenance mode is displayed.

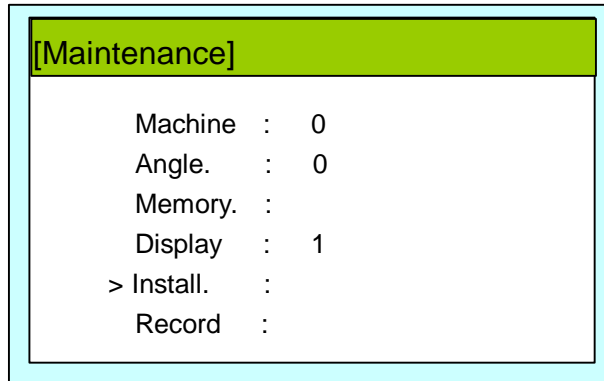

\* Please retry when you have display as "Error" by mistake of writing.

\* End of process.

1. Update of CPU board program

Insert CF card contains data for version up into CF card insertion slot.(FD Drive is for use of Floppy Disk).

2. Refer to [ 9-1 How to enter maintenance mode ] and enter maintenance mode.

3. Place cursor at [ Install ] by  button and press **SET** button.

4. Place cursor at [ HCDH\*\*\*\* ] by  button and press **SET** button. Installation of program for control of CPU board begins. Display comes as below.

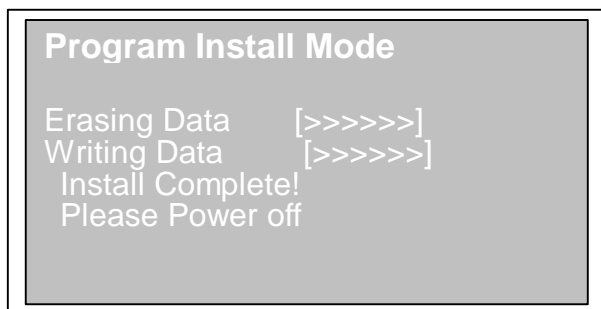
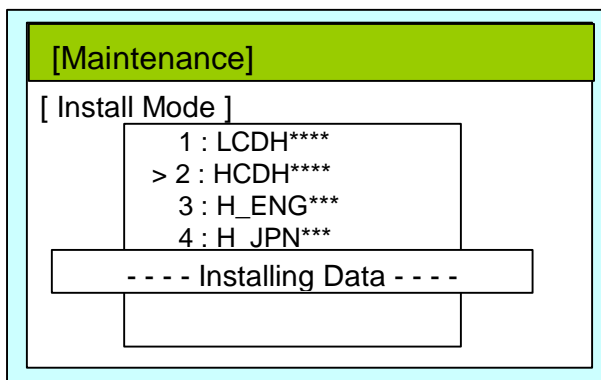

<NOTE>

1. Please do not take out CF card (Floppy Disk) during installation.

\* Please retry when you have display as "Error" by mistake of writing.

5. Once turn off power and turn on again.



\* Press **SET** button.

\* End of process.

1. Update of Frame Driving

Insert CF card contains data for version up into CF card insertion slot.(FD Drive is for use of Floppy Disk).

2. Refer to [ 9-1 How to enter maintenance mode ] and enter maintenance mode.

3. Place cursor at [ Install ] by  button and press **SET** button.

4. Set cursor at [ CD1A\*\* ] by  button and press **SET** button. Installation of data for frame driving starts.

\* Display is shown as below.

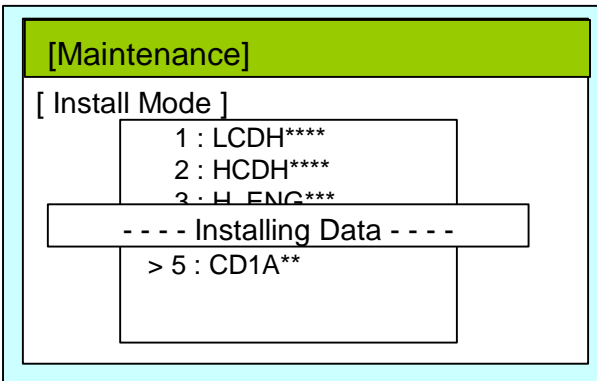

<NOTE>

- 1. Please do not take out CF card (Floppy Disk) during installation.
- 2. Please do not turn off the power during installation (it will take for a while for completion of installation.)

5. Message below will be shown after proper completion.

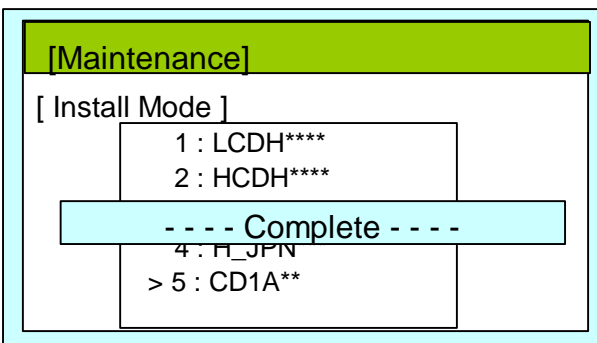

6. Only a short while later, maintenance mode is displayed.

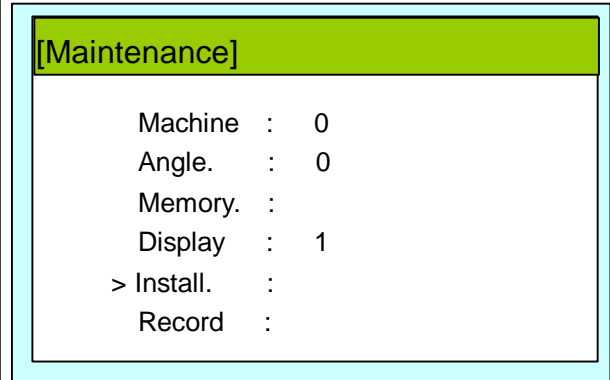

\* Please retry when you have display as "Error" by mistake of writing.

\* End of process.

## Initialization of memory

8-4

---

At time of start-up, this is to initialize work memory to specified value. Please initialize memory of ATA LCD board in case of update or change of program for LCD board control and when display is not shown normally. Please initialize memory of CPU board when you have a mechanical trouble. Resetting of revolution is required after initialization of CPU board.

---

### Initialization ATA LCD board memory

8-4-1

1. Please flip dipswitch DS1-1 on ATA LCD board. Then turn on the machine



2. End of initialize. Please turn off machine and flip back dipswitch DS1-1 to [OFF].

---

### Initialization CPU board memory

8-4-2

1. Set DS1-1 on CPU board to [ ON ] to turn power on.

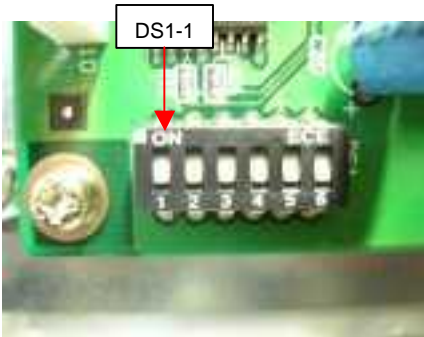

2. You will have no problem in starting and finishing initialization. Please turn power off to set DS1-1 to [ OFF ] after initialization
3. Please proceed with Automatic Speed Setting with reference to "25-1.2 Initialization of machine" of separate volume.

<NOTE> As memory area is not cleared, please refer to "13-3 Initialization of pattern memory" when you like to clear it.

## 9 Maintenance mode

9-1 How to enter Maintenance mode

9-2 Machine—Machine movement

9-3 Memory—Initialization of design memory

9-4 Record—Operation data display

9-4-1 Total number of stitch

9-4-2 Record of Error occurrence

9-4-3 Number of occurrence in each error display

9-5 Setup—Machine setting

9-6 Position—Registration of coordinates for positioning sensor

Maintenance mode is divided into 10 items as below.

- Machine———Movement test, maintenance and Adjustment.
- Angle———Angle display(Normally not used at maintenance)[0 fixation.]
- Memory———Initialization of design memory.
- Display———Switch over the display mode of LCD(Normally not used at maintenance)[1 fixation.]
- Install———Update of Control program Frame driving.Installation of Displayed language data(By CF card FD.)
- Record———Total number of stitch.Record of error occurrence. Number of occurrence in each error display.
- Setup———Modification of machine control setup data.
- Register———Registration of machine maintenance date(Normally not used at maintenance)
- Position———Registration of coordinates for positioning sensor
- OS update(with PC)——Update and Installation through PC (Update software will be needed separately)

## How to enter maintenance mode

Enable to enter maintenance mode with below procedure, which is not displayed normally.

1. Turn on machine with keep **MENU** button pressed

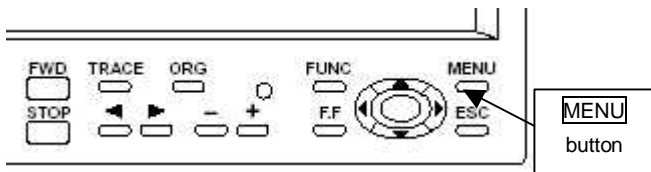

**<NOTE>**

Keep **MENU** button pressing until below display will come.



2. press **SET** button

**<NOTE>**

The frame has a sudden move. Keep hands away from the frame.

3. Below display will come

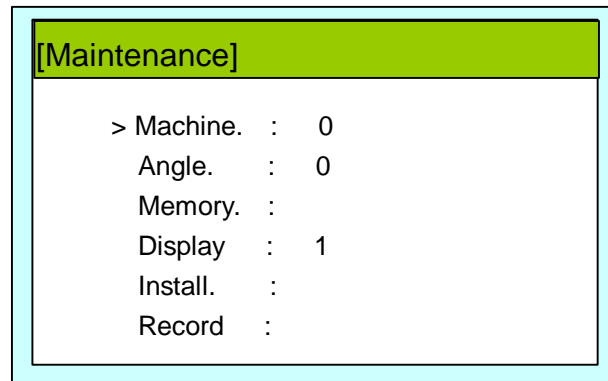

\* Turn of power again with procedure 1 and 2 if above display won't come.

4. Change to Drive display if you press **ESC** button at display of procedure 3.

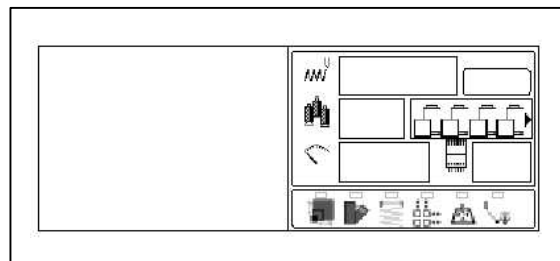

5. Once enter maintenance mode, you are able to enter maintenance mode again at anytime by keep pressing menu button at stand by display until turn off power.

Below operation will be moved solely. In some operations, actuator of motor will be moved, Keep hands and face away during movement for your own safety.

## Machine

- |   |  |
|---|--|
| <p>0 : All actuator OFF</p> <p>1 : Input test of L point C / point</p> <p>2 : Input test of Actuator origin point</p> <p>3 : Input test of alarm</p> <p>4 : Main shaft control test on low speed(80rpm) at start</p> <p>5 : Main shaft control test on low speed(120rpm) at thread</p> <p>6 : Main shaft control test on jog speed(10rpm)</p> <p>7 : (To be determined)</p> <p>8 : Sole movement test of jump solenoid ON-OFF</p> <p>9 : Sole movement test of thread catch hook IN-OUT</p> <p>10: Continuous action test of Thread catch hook (Include jump)</p> <p>11: Continuous action test of Keeper solenoid ON-OFF</p> <p>12: Movement Test of moving knife OPEN-CLOSE (1 step movement)</p> <p>13: Sole movement test of cooling fan ON-OFF</p> <p>14: (To be determined)</p> <p>15: Movement test of Keeper solenoid ON-OFF (1 step movement)</p> <p>16: Continuous action test of moving knife Open-Close</p> <p>17-19: (To be determined)</p> <p>20: Main shaft control test on voltage designation [0-5V](Jump)</p> <p>21: Automatic speed setting (Needle bar drive is selectable)</p> <p>22: Main shaft control test on speed designation (Needle bar drive)</p> <p>23: Main shaft control test on speed designation (Needle bar drive is selectable)</p> <p>24: Confirm of Minimum speed and Maximum speed (Jump)</p> <p>25: Sole movement test of Jump solenoid ON-OFF</p> <p>26: (To be determined)</p> <p>27: Main shaft control test of jog speed (10rpm)</p> <p>28: Main shaft control test on low speed (80rpm) at start</p> <p>29: Main shaft control test on low speed (120rpm) at thread trim</p> | <p>30: Voltage control test of Needle bar change unit (Holding)</p> <p>31: Input of Needle bar detect Potentiometer (For installation adjustment)</p> <p>32: Movement test of Needle bar change unit (every 1 needle to the right direction)</p> <p>33: Movement test of Needle bar change unit (every 1 needle to the left direction)</p> <p>34-39: (To be determined)</p> <p>40: Input test of Button switch</p> <p>41: Input test of Limit switch</p> <p>42: Input test of L point / C point</p> <p>43: Input test of Actuator origin point</p> <p>44: Input test of alarm</p> <p>45: Display of operational state for USB</p> <p>46-49: (To be determined)</p> <p>50: Voltage control test of Thread cut motor (Holding)</p> <p>51: 1 Pulse drive movement of Thread cut motor (For adjustment)</p> <p>52: Return performance from distribution of Thread cut motor</p> <p>53: Movement Test of moving knife OPEN-CLOSE (1 step movement)</p> <p>54: Continuous action test of moving knife Open-Close</p> <p>55-59: (To be determined)</p> <p>60: Voltage control test of Thread catch motor (Holding)</p> <p>61: 1 Pulse drive movement of Thread catch motor (For adjustment)</p> <p>62: Return movement from distribution of Thread catch hook</p> <p>63: Sole movement test of thread catch hook IN-OUT</p> <p>64: Block movement test of thread catch hook IN-OUT</p> <p>65-69: (To be determined)</p> |
|---|--|

Machine

- 70: Disabled
- 71: Disabled
- 72: Disabled
- 73: Disabled
- 74: Disabled
- 75-79: (To be determined)

- 80: Deletion of frame drive data
- 81: Deletion of frame position data
- 82: Deletion of speed data
- 83: Deletion of machine setting data
- 84-88: (To be determined)
- 89: Deletion of all installation data

- 90-98: (To be determined)
- 99: Permission of full installation of Operating system (Power cutoff prohibition)
- 100-250: Direct designation of rotation control per 10rpm(0-1200rpm)

Machine—Machine movement

1. Enter maintenance mode in reference to [9-1 How to enter maintenance mode]

2. Choose [ Machine ] with  and press **SET** button

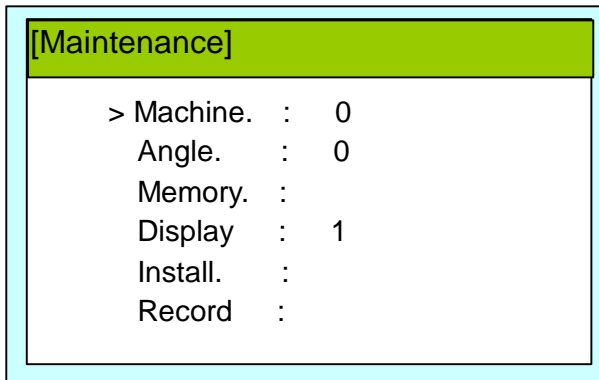

3. Press  to select desired number to be confirmed and press **SET** button [ # ] mark will be displayed left side of desired number to be confirmed and selected item will be executed

\* Below is Main shaft control test on speed designation

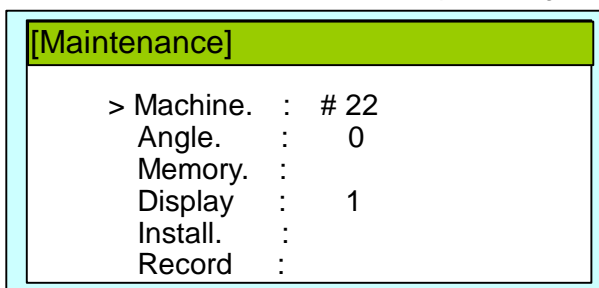

4. By pressing **ESC** button [ # ] mark will be disappear and return to number setting display (Unnecessary to press **ESC** button if the item complete automatically)

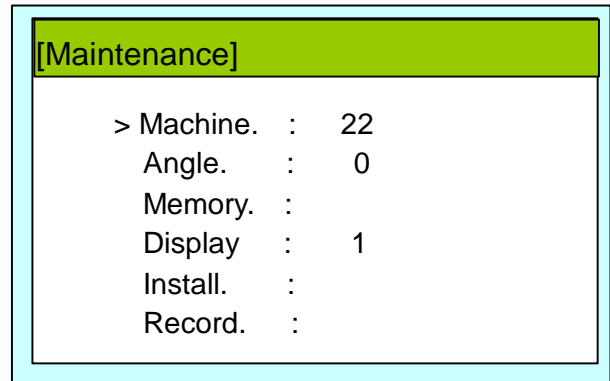

5. Enable to Quit maintenance mode and return to drive mode by pressing **ESC** button

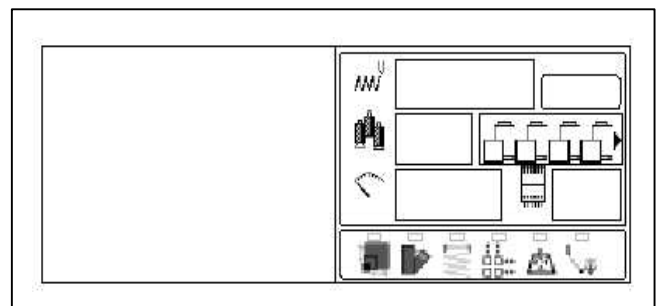

Delete all the design memory with checking movement of design memory area.

Execute this function when occurring design breakage or impossibility of design input.

In case of deflection, board exchange may be suggested and it is conceivable cause of deflection.

**<NOTE>**

All the internal design memory will be deleted by initialization of design memory.

You have to be careful when initializing design memory.

1. Enter maintenance mode in reference to [9-1 How to enter maintenance mode ]

2. Choose [ Memory ] with  and press **SET** button

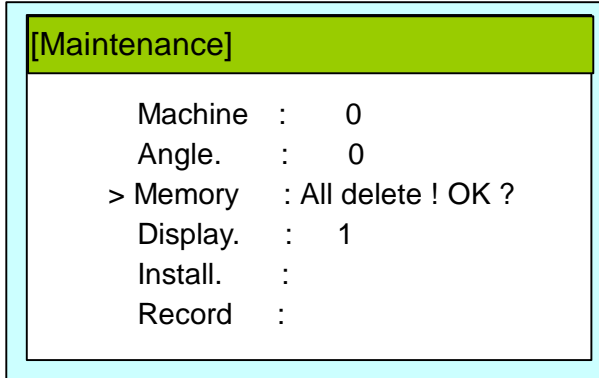

\* Above will be displayed

3. Confirm of free area and all delete will be started after pressing **SET** button

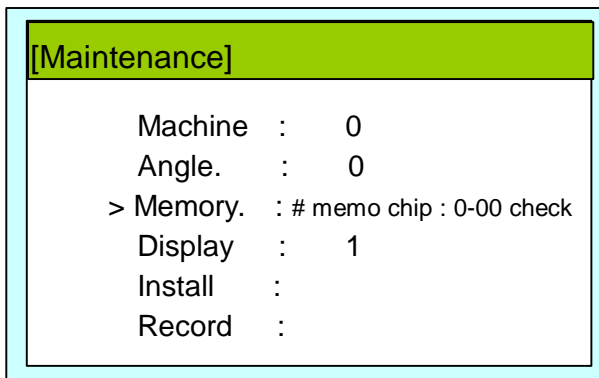

4. After display of [Chip:\*-15], buzzer sounds and complete with below display.

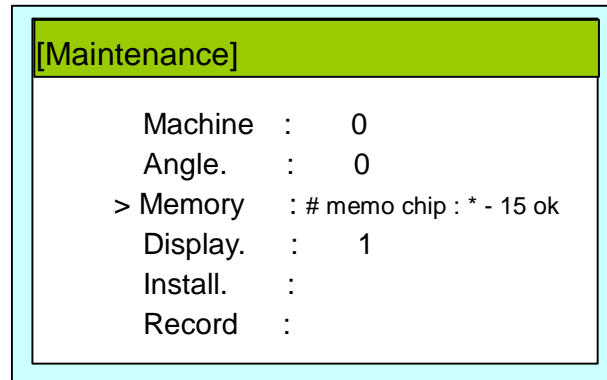

5. Below will displayed when there is defect.

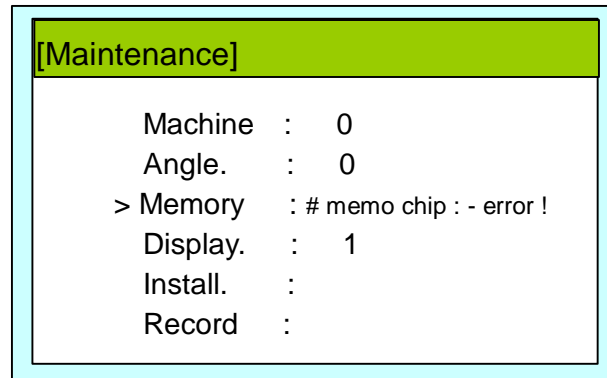

6. Return to number setting display by pressing **SET** button

7. Return to drive mode by pressing **ESC** button

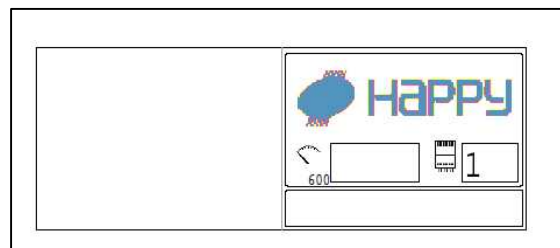

Enable to confirm past record of operation

Record—Total number of stitch—: Total stitch number that are embroidered till now

button ↓↑  button

Record of error occurrence—: Occurrence date and error number of last 32 case

button ↓↑  button

Total number of each error—: Integrated value for each error

## Total number of stitch

1. Enter maintenance mode in reference to [ 9-1 How to enter maintenance mode ]

2. Choose [ Record ] with  and press  button.

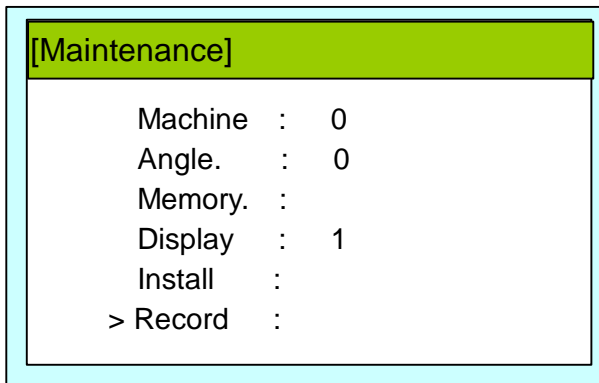

3. Below will displayed

Total number of stitch till now will be displayed.

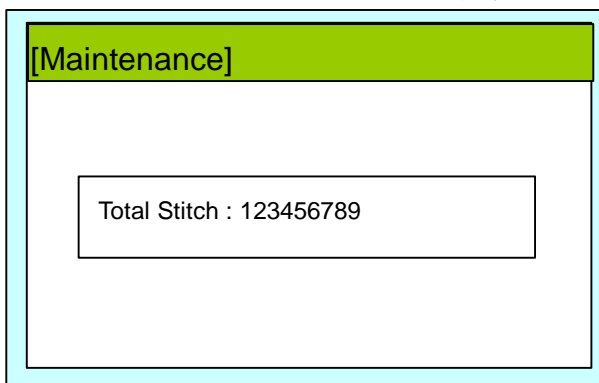

4. Selection menu of Clear Total Stitch will be opened when pressing  button at Procedure 3.

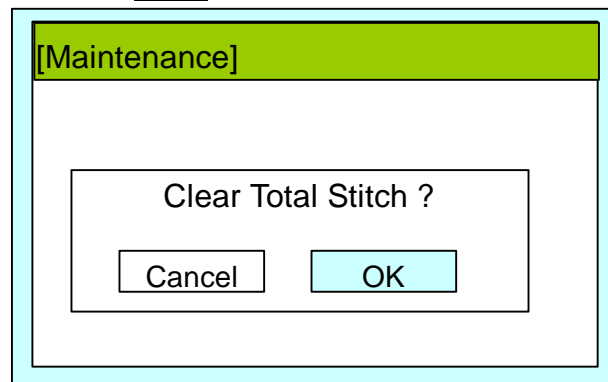

\* Enable to Clear Total Stitch by selecting  and pressing  button and return to display of procedure 3.

\* If you prefer not to clear it, select  and press  button and return to display of procedure 3.

1. Enter maintenance mode in reference to [ 9-1 How to enter maintenance mode ]
2. Choose [ Record ] with  and press **SET** button  
(Total number of stitch will be displayed)
3. Press SET button at displayed window of Total stitch.  
Enable to confirm Record of error occurrence  
(Date of occurrence and error number of last 32 cases)

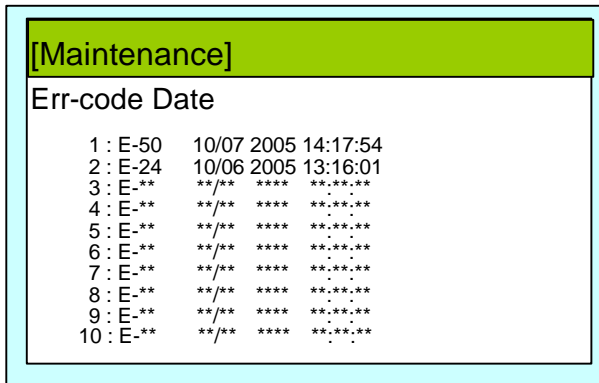

\* Enable to confirm Occurrence date and error number of last 32 cases with  button.

4. Selection menu of Clear Error Recode will be opened when press **MENU** button at display of procedure 3

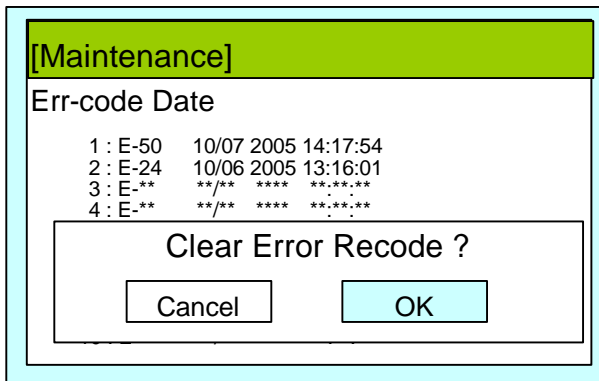

\* Enable to Clear Error Record by selecting **OK** and pressing **SET** button and return to display of Procedure 3.

\* If you prefer not to clear it, Select **CANCEL** and press **SET** button and return to display of Procedure 3.

1. Enter maintenance mode in reference to [ 9-1 How to enter maintenance mode ]

2. Choose [ Record ] with  and press **SET** button  
(Total number of stitch will be displayed)

3. Press **SET** button at displayed window of Total stitch.  
Enable to confirm Record of error occurrence.

4. Press **MENU** button at displayed window of Error occurrence record. Enable to confirm total number of occurrence in each error.  
(E-000 to E-255 will be displayed )

[Maintenance]			
Err – code cnt		Err – code cnt	
E-000 :	0	E-010 :	0
E-001 :	0	E-011 :	0
E-002 :	0	E-012 :	0
E-003 :	0	E-013 :	0
E-004 :	0	E-014 :	0
E-005 :	0	E-015 :	0
E-006 :	0	E-016 :	0
E-007 :	0	E-017 :	0
E-008 :	0	E-018 :	2
E-009 :	0	E-019 :	0

\* Enable to confirm integrated value for E-000 to E-255 with  button.

5. Selection menu of Clear Error Total Count will be opened when press **MENU** button at display of procedure 4.

[Maintenance]			
Err – code cnt		Err – code cnt	
E-000 :	0	E-010 :	0
E-001 :	0	E-011 :	0
E-002 :	0	E-012 :	0
E-003 :	0	E-013 :	0
E-004 :	0	E-014 :	0

Clear Error Total Count ?

Cancel
OK

- \* Enable to Clear Error Record by selecting **OK** and pressing **SET** button and return to display of Procedure 4
- \* If you prefer not to clear it, Select **CANCEL** and press **SET** button and return to display of Procedure 4.

Basic machine setting will be done. All the setting will be written into built-in Flash Memory card and setting contents will not be deleted even if you proceed all memory clear.

<NOTE>Be sure to confirm us when you modify below setting contents( Change setting of “ \* “ mark are prohibited)

Contents

* Max Needle Number.	: 15	(1-15.)	: Number of Needle
* Max Head Number	: 1	(1-30.)	: Number of Head
* Needle Sensor type.	: Potentio.	(or photo S.)	: Needle position detect sensor type
* Needle Motor type.	: Pulse.Mtr.	(Rev.DCM.)	: Needle motor type
* Frame Sensor type.	: Point s.		: Carriage sensor type
	( Center.S ABS.C ABS.RF Limit.C Limit.RF )		
* Frame Motor Type.	: Pulse Mtr.	(Servo Mtr.)	: Frame drive motor type
* THD. Break Sensor.	:Rotary S.	(PinPin S.)	: Thread break detect sensor
Borrer device	: No.		: Use of Borrer device Yes or No
* Cut device.	: Yes.		: Use of Automatic thread cut device Yes or No
* LED Needle Pointer.	: No		: Use of LED Pointer Yes or No
* Stop 300rpm drive	: 2	(2.3.)	: Number of 300rpm drive at the time of stoppage
* Caution output.	: No		: Output for external contact
* Detection test.	: No		: Test of Thread break detect
X Start base angle.	: 50	(20-90)	: Starting angle of frame movement on X axis
Y Start base angle.	: 50	(20-90)	: Starting angle of frame movement on Y axis
* Keeper off N. tmg.	: 250.	(180-250)	: Thread trim(Normal) Turn OFF timing of Keeper
* Keeper off L. tmg.	: 250	(180-250)	: Thread(Long) Turn OFF timing of Keeper
* Stop sycle speed.	: 600	(100-1000)	: Speed of Middle range drive at the time of stoppage
* Cut sycle speed.	: 400	(100-1000)	: Speed of Middle range drive at the time of thread trim
* Needle start time.	: 100	(100-1000)	: Constant 1 of Needle bar change control
* Needle drive time.	: 500.	(100-2000)	: Constant 2 of Needle bar change control
* Needle brake time.	: 20	(10-100.)	: Constant 3 of Needle bar change control
* Speed Calc. Angle.	: 15	(1-360.)	: Constant of Speed calculation
* Communicate Check.	: 10	(1-20.)	: Signal control 1
* Communicate Wait.	: 10	(1-20.)	: Signal control 2
* OPTION.	: Yes		: Use of Option Yes or No (To be determined)
* Y Encoder limit.	: 5	(1-100.)	: Carriage control Signal 1
* Machine Max Speed.	: 1200	(500-2000)	: Maximum rotation
* Machine Eria X.	: 520	(1-1000)	: Maximum embroidery area at X axis
* Machine Eria Y.	: 400	(1-1000.)	: Maximum embroidery area at Y axis
* X Center Sensor No.	: 2	(0-12.)	: Center sensor number of X axis
* Y Center Sensor No.	: 0	(0-12.)	: Center sensor number of Y axis
* X Position Sensor.	: 6	(0-12.)	: Number of position sensor at X axis
* Y Position Sensor.	: 4	(0-12.)	: Number of position sensor at Y axis
* Current Voltage.	:130	(0-230.)	: Constant 1 of Motor power control
* Low Power Voltage	:160	(0-230)	: Constant 2 of Motor power control
* High Power Voltage.	:220	(0-230)	: Constant 3 of Motor power control
* Normal Stop Angle.	: 270.	(200-300.)	: Normal stoppage angle
* Cut Stop Angle	: 270.	(200-300.)	: Thread cut stoppage angle
* N.Stop Auto Calc	: Yes		: Automatic calculation of normal stoppage angle

Contents

* C.Stop Auto Calc.	: Yes		: Automatic calculation of Thread trim stoppage angle
* Jump ON1(*250us.)	: 8	(2-100)	: Constant 1 of Jump control
* Jump ON2(*250us.)	: 40	(2-100)	: Constant 2 of Jump control
* Brush Data [mm.]	: 20	(1-25.)	: Distance of Frame movement at thread brush
* Safety Sensor	: No.		: Use of safety sensor( rear )Yes or No( To be determined )
N.Safety Sensor	: No.		: Use of safety sensor(front) Yes or No
* Front Cover Sensor.	: No		: Use of front cover sensor Yes or No(To be determined)
* Change Point Angle	: 275.	(0-360)	: C point angle(Target angle of stoppage)

1. Enter maintenance mode in reference to [ 9-1 How to enter maintenance mode ]

2. Choose [ Setup ] with  and press **SET** button

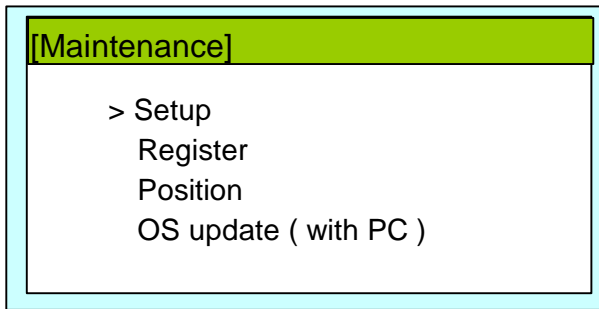

3. Press  to select desired number to be confirmed and press **SET** Button

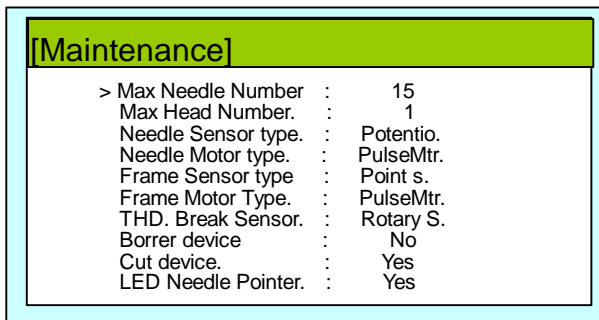

4. Selected setting number will be turned into blue. Modify setting by pressing  button and press **SET** button.

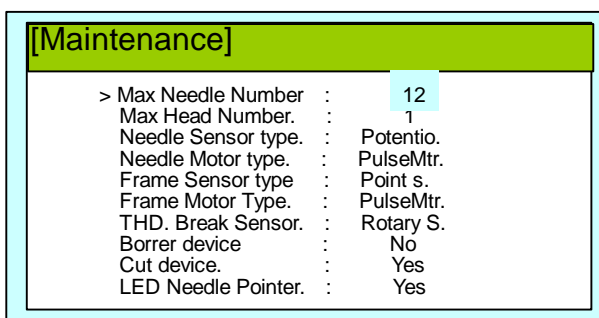

5. Press **ESC** button after modifying of setting number. Confirmation message will be displayed as below, select [ OK ] with  button and press **SET** button.

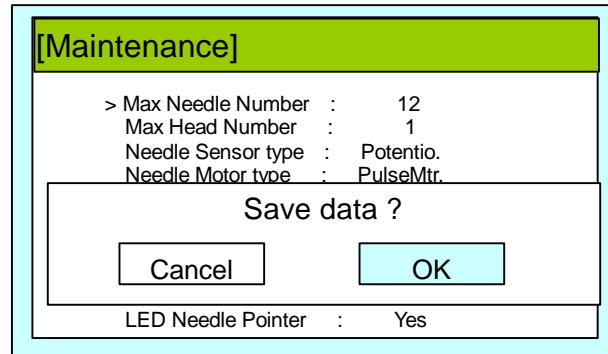

6. Below message will be displayed and saved into built-in flash memory.

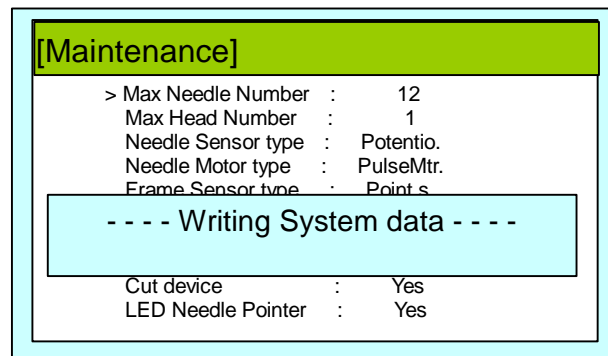

7. Once update is done, return to display of procedure 2

8. Return to drive mode by pressing **ESC** button

9. Turn off power and restart before use a machine

This procedure is to memorize embroidery area into the machine.

This procedure has to be done after exchange of CPU board.

(Machine will display error [ E-67 Position data ] without the registration of coordinate of Position sensor.

**<NOTE>**

\* Registration should be done with cover installed. Correct position may not be registered if the registration is done with the cover off.

\* As frame moves at maximum embroidery area, be sure not to have anything around the machine.

1. Enter maintenance mode in reference to [ 9-1 How to enter maintenance mode]

2. Choose [ Setup ] with  and press **SET** button

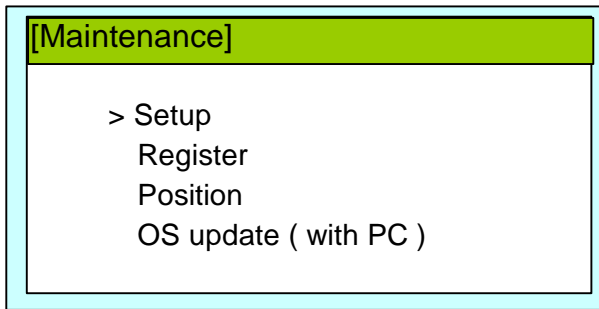

3. Select page number 3 with  button

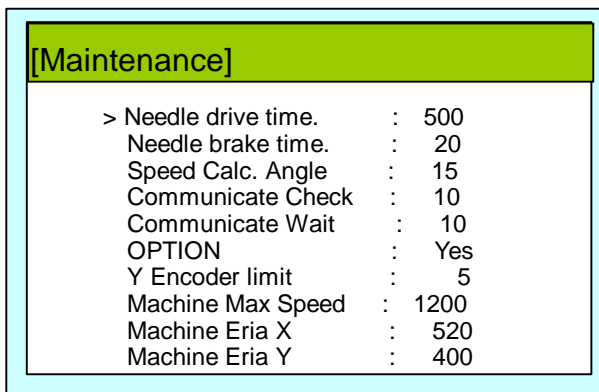

**<Check>**

In case of HCD, confirm machine setting is as below.

Machine area X : 520

Machine area Y : 400

4. Select page number 4 with  button

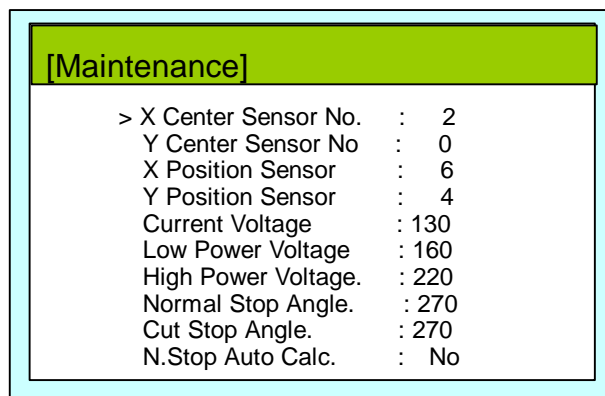

**<Check>**

In case of HCD, confirm machine setting is as below.

X Center Sensor No : 2

Y Center Sensor No : 0

X Position Sensor : 6

Y Position Sensor : 4

5. Return to [Procedure 2] by pressing **ESC** button

6. Select [ Position ] with  button and press **SET** button

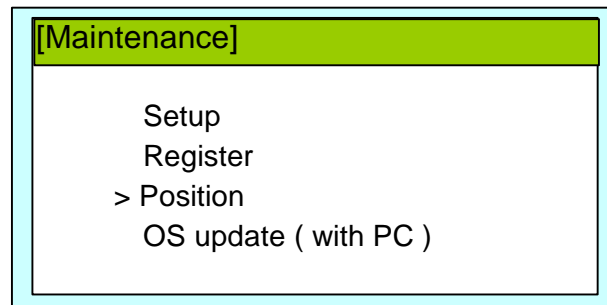

7. Operate according to displayed below message.

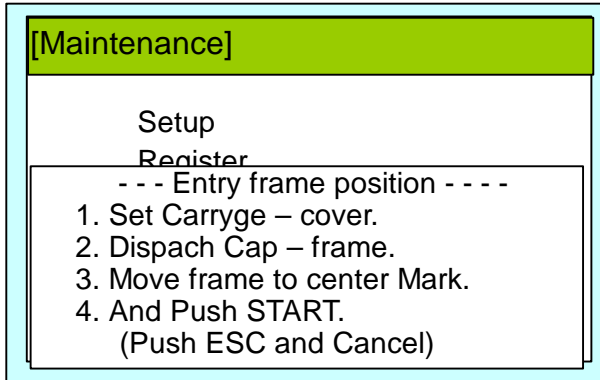

1. Fix carriage cover
2. Remove cap frame
3. Move frame to center mark position  
(Refer to below display)
4. Press **START** button  
(Press **ESC** button in case of cancellation)



Center mark position of X axis

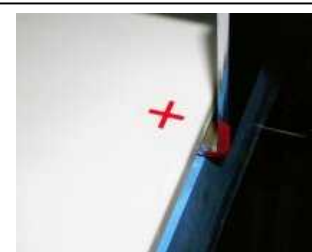

Center mark position of Y axis

8. When you press **START** button, registration of X axis direction will start. Frame moves 1.2.3.4 as in the below displayed order.

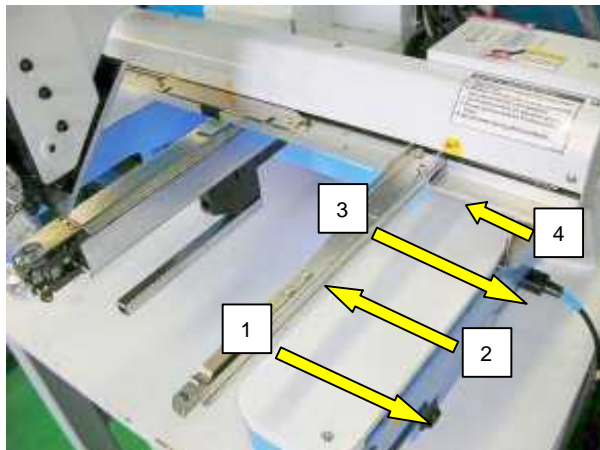

9. Go on to registration of Y axis direction. Frame moves 1.2.3.4 as in the below displayed order.

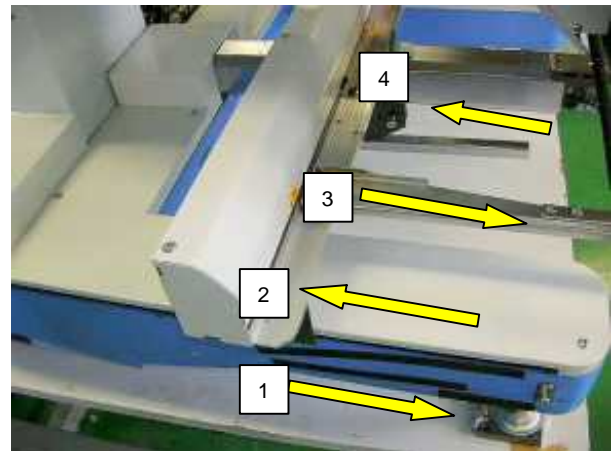

10. Below message will be displayed with successful completion.

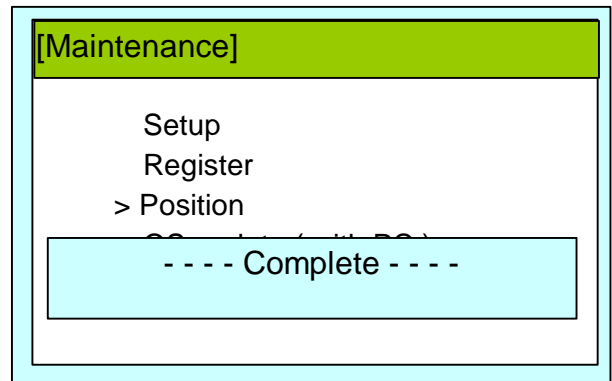

\* Retry from procedure 2 if [Error] occurs.

Frame position registration is finished.

# 10 Revolution

## 10-1 Setting of Revolution

Setting of revolution of main shaft, which is suitable to the machine is required.

If setting is not done, the revolution may not speed up.

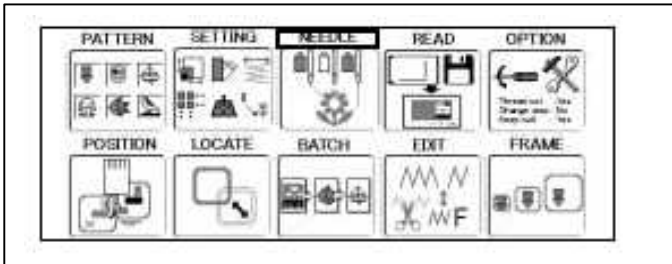

1. Turn on the power. After the program start up, press **MENU** button.

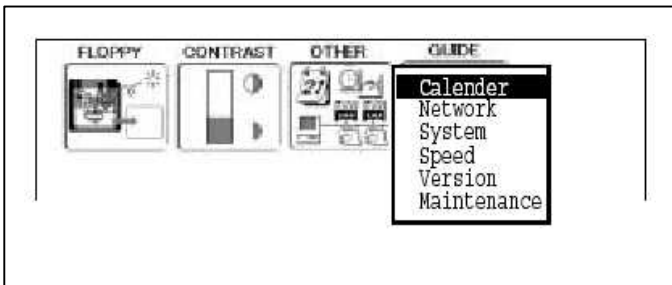

2. Press  to select **OTHER** window and press **SET** button.

Displayed as bellow.



3. Press  to select **Speed** and press **SET** button.  
Press  to select **[OK]** and press **SET** button.

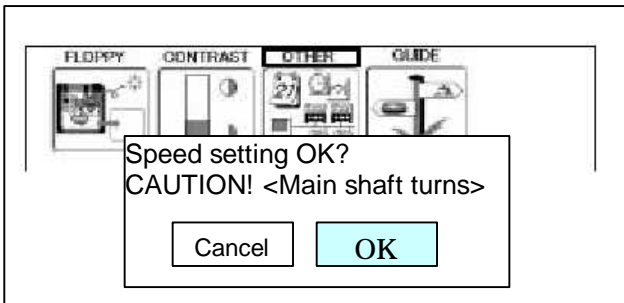

5. Main shaft adjusts its revolution speed automatically. Message **complete** will be displayed when setting is finished and it goes back to drive mode.

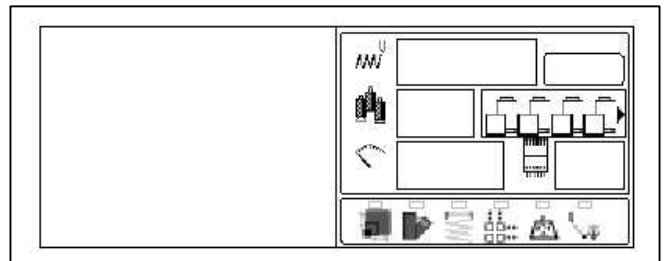
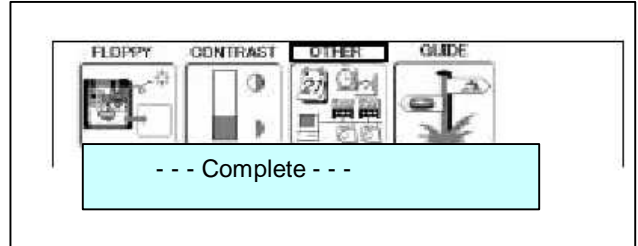

\* End of process.

## 11 Electric system diagram

11-1 Electrical connection diagram

11-2 List of electrical connection diagrams

11-3 Reference diagram for wiring (AC line)

11-4 FR-S510W type Inverter wiring and parameter setting. (For 110V)

11-5 VFNC1(S) type Inverter wiring and parameter setting. (For 220V)

Electrical connection diagram 1/2

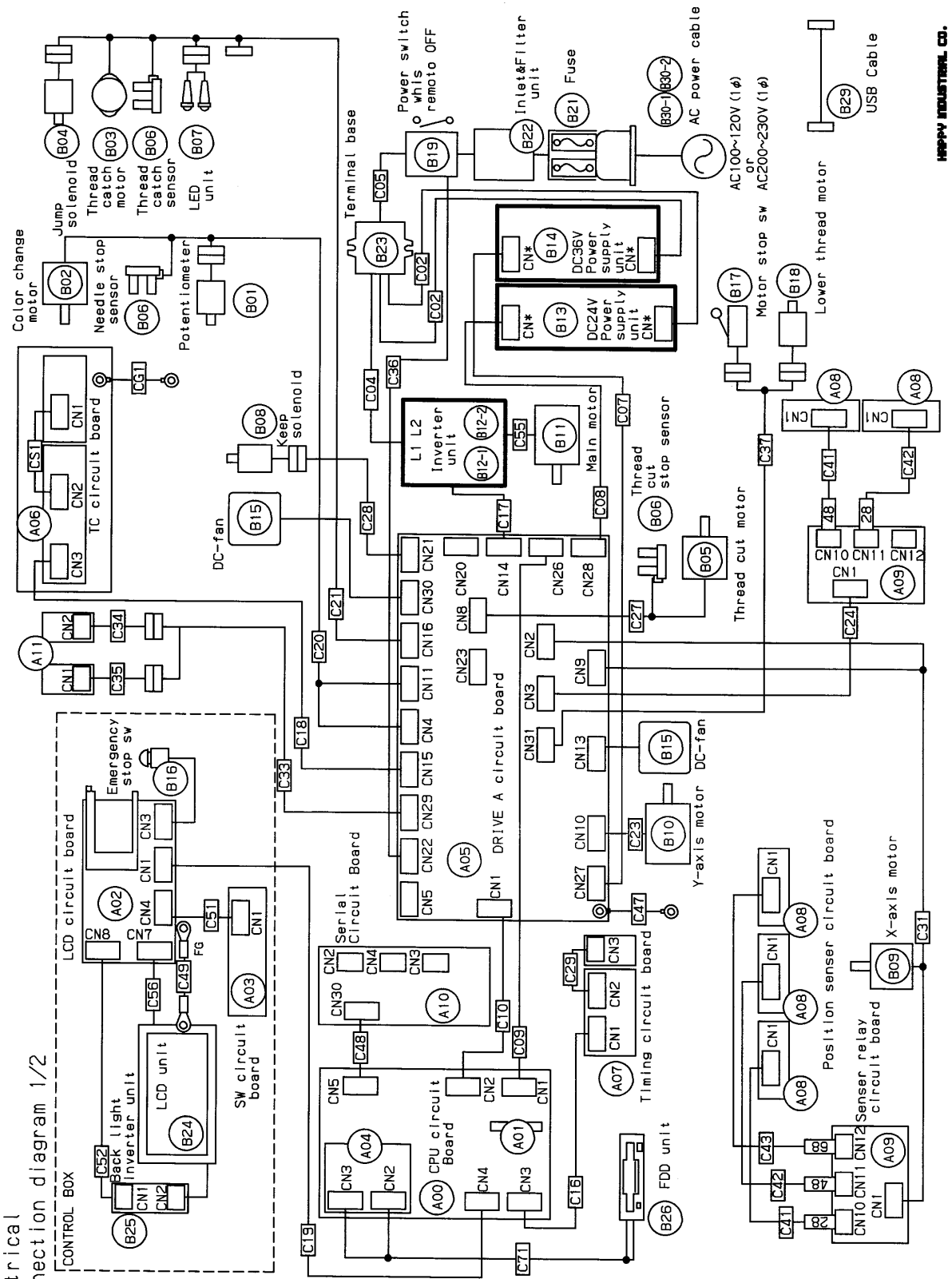

HAPPY INDUSTRIAL CO.

# List of electrical connection diagrams

## Electrical connection diagram 2/2

Parts Names	Parts No.	Main motor	ESHCA7501* 3φ 200V	TC cable	ESHCD7018*	Ground cable	ESHCG7007*
CPU circuit board	ESHCD8100*	Input110V type inverter unit	ESHCD7925*	DISP cable	ESHCD7019*	CG1	
LCD&TACF circuit board	ESHCD8102*	Input220V type inverter unit	ESHCD7927*	Needle bar change cable	ESHCD7020*	B29	ESEPF70075*
Switch circuit board	ESHCD8103*	Output24V type power supply	ESEPK0093* AEST5-24F (NAGANOMUSEN)	Jump&Thread catch cable	ESHCD7021*	B30-1	ESEPF0009* (A2 type)
DRIVE-A circuit board	ESHCD8105*	Output36V type power supply	ESEPK0094* LEP150F-36 (COSEL)	Y-motor cable	ESHCD7023*	B30-2	ESEPE0010* (C4 type) ESEPE0011* (BF type) ESHCD7931*
TC circuit board	ESHCD8106*	DC fan unit	ESHCD7916* F412RS24MB-01 (COPAL)	Y-sensor relay cable	ESHCD7024*		
Timing circuit board	ESHCD8109*	Emergency stop sw	ESHCD7900*	Thread cut motor cable	ESHCD7027*	(OPTION)	
Position sensor circuit board	ESHCD8110*	Power switch	ESEPS0089* AJBR2014BBC (MATSUSITA)	Keep relay cable	ESHCD7028*	A01	ESHCD8101*
Sensor Relay circuit board	ESHCD8111*	Fuse	ESEPF0036* 3SB6A (Be1) 250V 6A	Encoder relay cable	ESHCD7029*		
Serial circuit board	ESHCB8107*	Inlet&Filter unit	ESHCD7918*	X-motor cable	ESHCD7031*	A04	ESHCD8104*
Potentiometer	ESHCB7940*	Terminal base	ESEPF0043* ML-1700-B2P ORBL (SATO)	PD cable	ESHCD7036*	B26	ESEPF0028* FD-235-HG (TEAC)
Color change motor	ESHCD7911*	LCD unit	ESEPT0079* KCG089HVJAA-G00 (KYOSERA)	DC-motor Relay cable	ESHCD7037*	C71	ESHCD7071*
Thread catch motor	ESEPM0052* 42S1A24D5B2 (MATSUSITA)	Back light inverter unit	ESEPT0080* CXA-L0605-VJL (TDK)	Limit relay cable	ESHCD7041*		
Jump solenoid	ESHCB7901*	Power Supply cable	ESHCD7002*	Limit relay (480) cable	ESHCD7042*	B17	ESHCD7922*
Thread cut motor	ESHCB7920*	Inverter power supply cable	ESHCD7004*	Limit relay (680) cable	ESHCD7043*	B18	ESHCD7921* LC30-191BA (COPAL)
Photo sensor	ESEPP0052* GPIA73A (SHARP)	Power supply relay cable	ESHCD7005*	Ground cable	ESHCD7047*	A11	ESHCD8112*
LED unit	ESHCD7915*	DC36 power supply cable	ESHCD7007*	Serial relay cable	ESHCD7048*	C33	ESHCD7033*
Keep solenoid	ESHCD7905* SK0730A12BX (SHINDENGEN)	DC24 power supply cable	ESHCD7008*	LCD Ground cable	ESHCD7049*	C34	ESHCD7034*
X-axis motor	ESHCD7912*	CPU power cable	ESHCD7009*	SW cable	ESHCD7051*	C35	ESHCD7035*
Y-axis motor	103HT822-0446 (SANYO DENKI) 103HT823-0440 (SANYO DENKI)	Drive S cable	ESHCD7010*	BL-Inverter cable	ESHCD7052*		
		Timing cable	ESHCD7016*	MOTER cable	ESHCD7055*		
		Inverter cable	ESHCD7017*	LCD-S (8.9 inch) cable	ESHCD7056*		
				TC connecting cable	ESHCB7019*		

Attention  
 -Inverter  
 -AC power cable  
 Product varies in a power supply to use

\*mark is a revision number

HAPPY INDUSTRIAL CO.

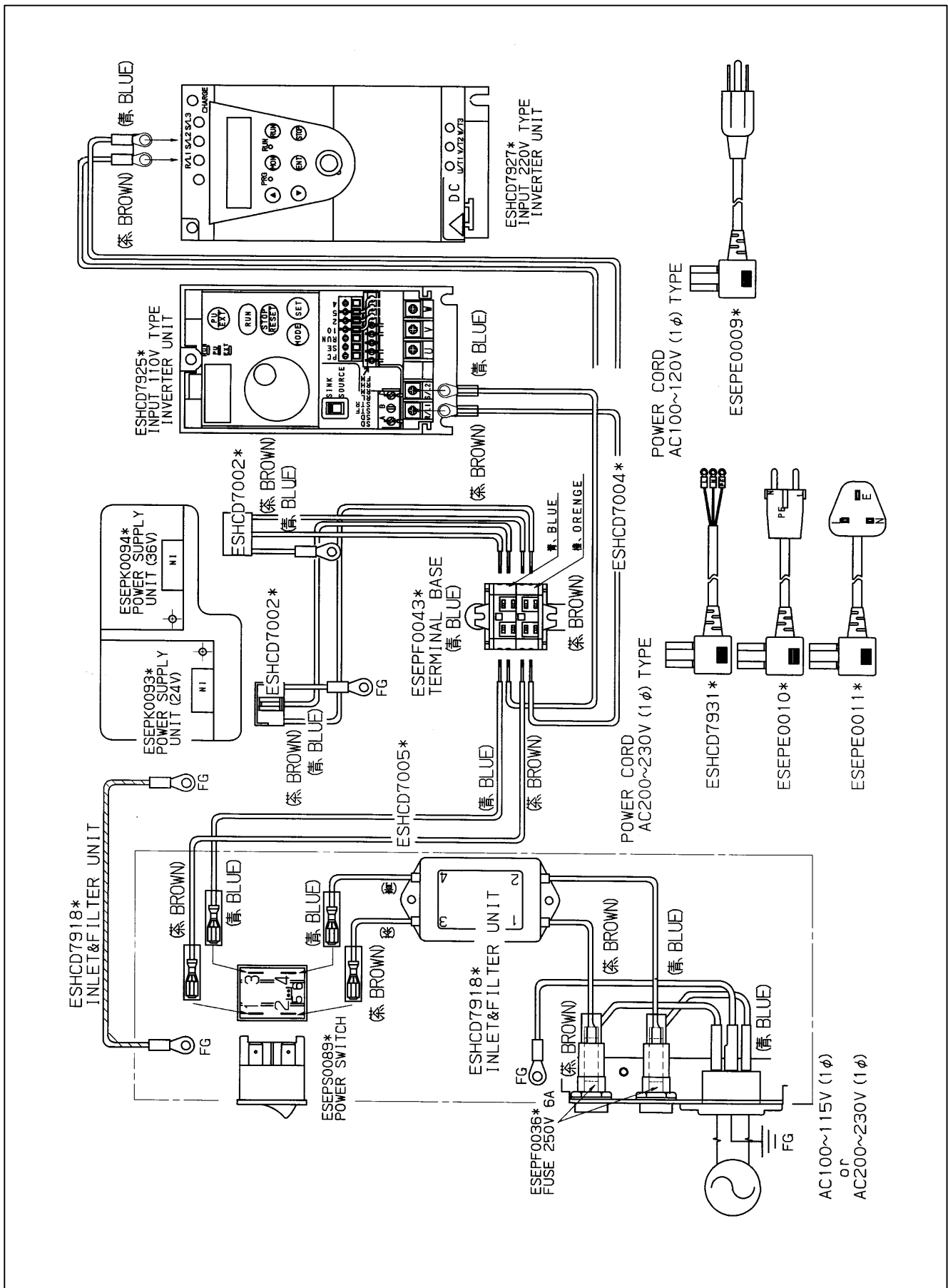

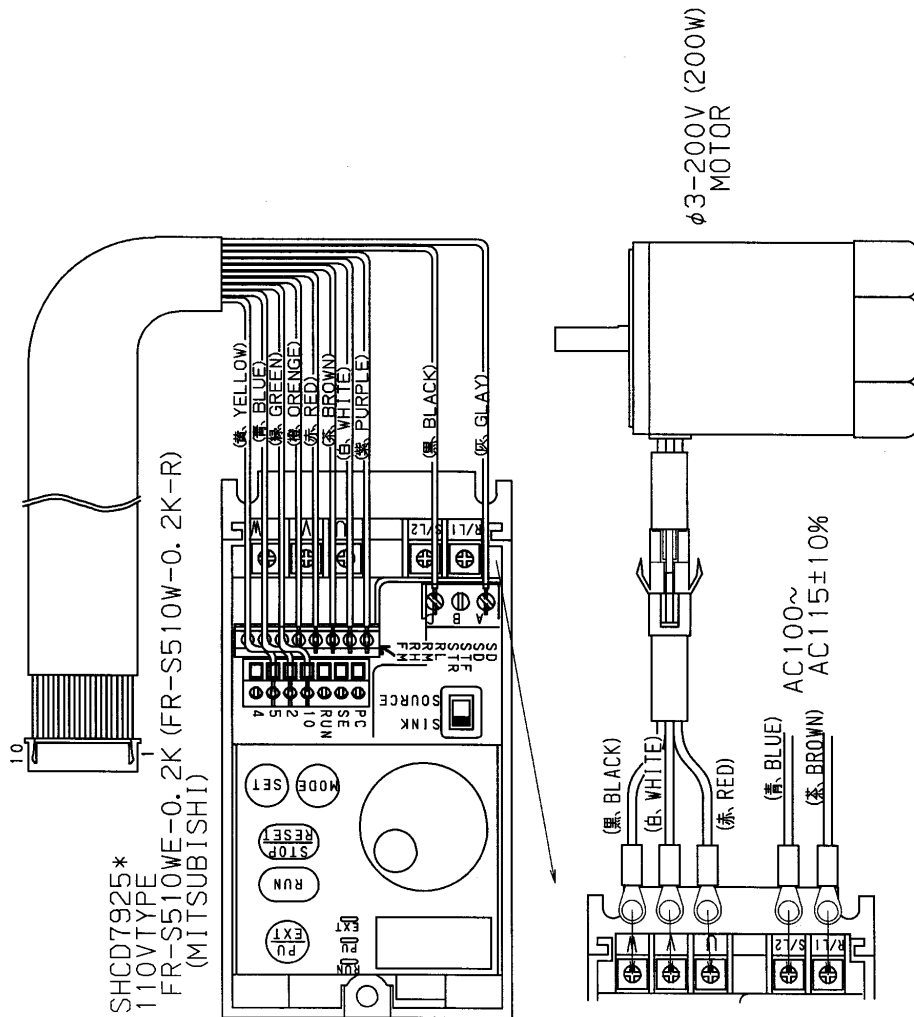

Parameters (No indication default setting)

Parameters	-Setting
Title Function	●ESHCD7925* 110VTYPE
P30 Extend function display selection	→ 1
P79 Operation mode selection	→ 2
P 0 Torque boost	→ 12.0
P 1 Maximum frequency	→ 120.0
P 2 Minimum frequency	→ 0.0
P 3 Base frequency	→ 60.0
P 6 Low-speed setting	→ 2.5
P 7 Acceleration time	→ 2.0
P 8 Deceleration time	→ 0.3
P 9 Electronic thermal O/L relay	→ 1.0
P10 DC injection brake operation frequency	→ 1.0
P11 DC injection brake operation time	→ 0.5
P12 DC injection brake operation voltage	→ 12.0
P15 Jog frequency	→ 2.5
P16 Jog acceleration /deceleration time	→ 0.1
P20 Acceleration/deceleration reference frequency	→ 120.0
P38 Frequency setting voltage gain frequency	→ 120.0
P60 RL terminal function selection	→ 9
P70 Soft-PWM setting	→ 0
P72 PWM frequency selection	→ 2
P74 Input filter time constant	→ 4
P75 Reset selection	→ 0
P98 Automatic torque boost selection	→ 0.18
C4 Frequency setting voltage gain	→ 82.0
P77 Parameter write disable selection (Setting→2,Disable→1)	→ 1

Parameters (No indication default setting)

Basic Parameters

Title	Function	→Setting
Cn0d	Command mode	→ 0
Fn0d	Frequency set mode	→ 2.0
ACC	Acceleration time1	→ 0.3
dEC	Deceleration time1	→ 120.0
FH	Maximum frequency	→ 120.0
UL	Upper limit frequency	→ 0.0
LL	Lower limit frequency	→ 60.0
PL	V/L control mode	→ 3
Ub	Torque boost1	→ 12.0
=Hr	Motor thermal protection level1	→ 80
Sr1	Preset speed operation frequency1	→ 2.0

Extended parameters

Title	Function	→Setting
F109	Analog input/logic input function selection	→ 0
F113	Input terminal selection3(S1)	→ 22
F201	VI/S3 reference point1	→ 0
F202	VI/S3 point1 frequency	→ 0.0
F203	VI/S3 reference point12	→ 43
F204	VI/S3 point1 frequency2	→ 120
F250	DC braking starting frequency	→ 1.5
F251	DC braking current	→ 20
F252	DC braking time	→ 1.0
F300	PWM carrier frequency	→ 5
F401	Slip frequency gain	→ 100
F409	Base frequency volteasel	→ 200
F415	Motor no-load current	→ 1.2
F416	Motor rated current	→ 60
F417	Motor rated speed	→ 1600
F418	Speed control gain	→ 60
F419	Speed control stable coefficient	→ 10
F500	Acceleration time2	→ 2.0
F501	Deceleration time2	→ 0.3
F505	ACC/DCC land2 switching frequency	→ 20.0
F601	Stall prevention level	→ 50
F700	Prohibition of change parameter settings	→ 1

(0=Setting)

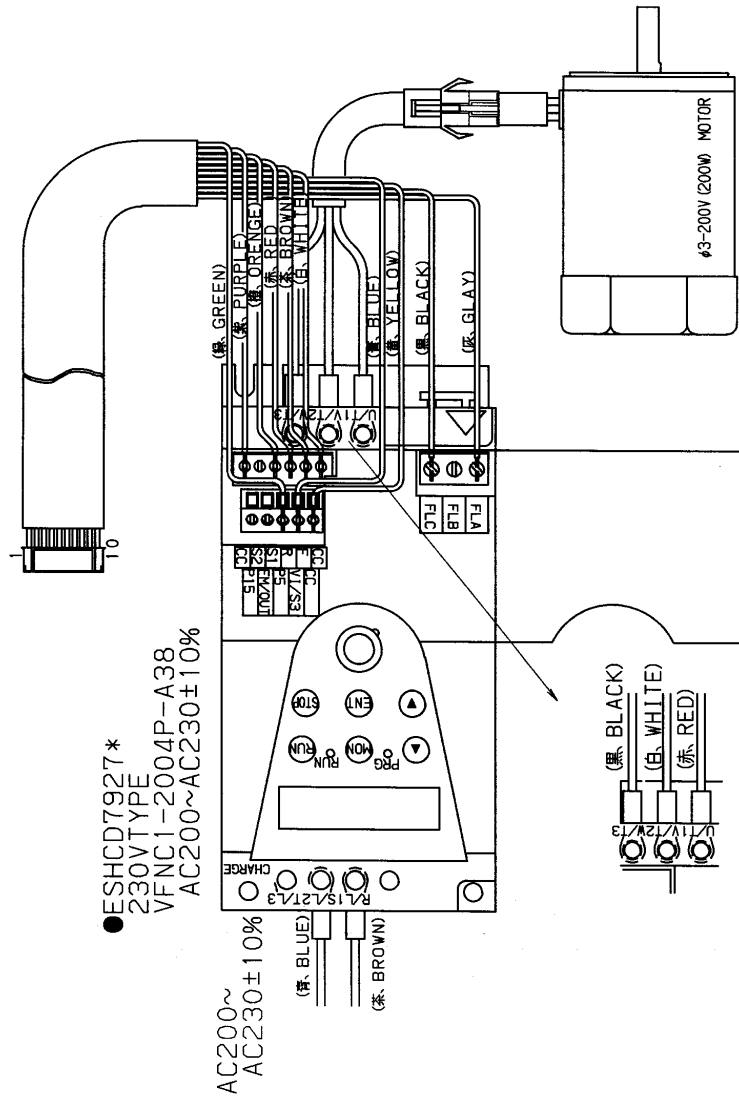

## 12. Others

- 12-1 How to respond for some question (As example step)
- 12-2 Trouble shooting
- 12-3 Error
- 12-4 Reference date

# How to respond for some question (As example step)

\*When you receive some question from customer, please use this step for sold problem as sample.

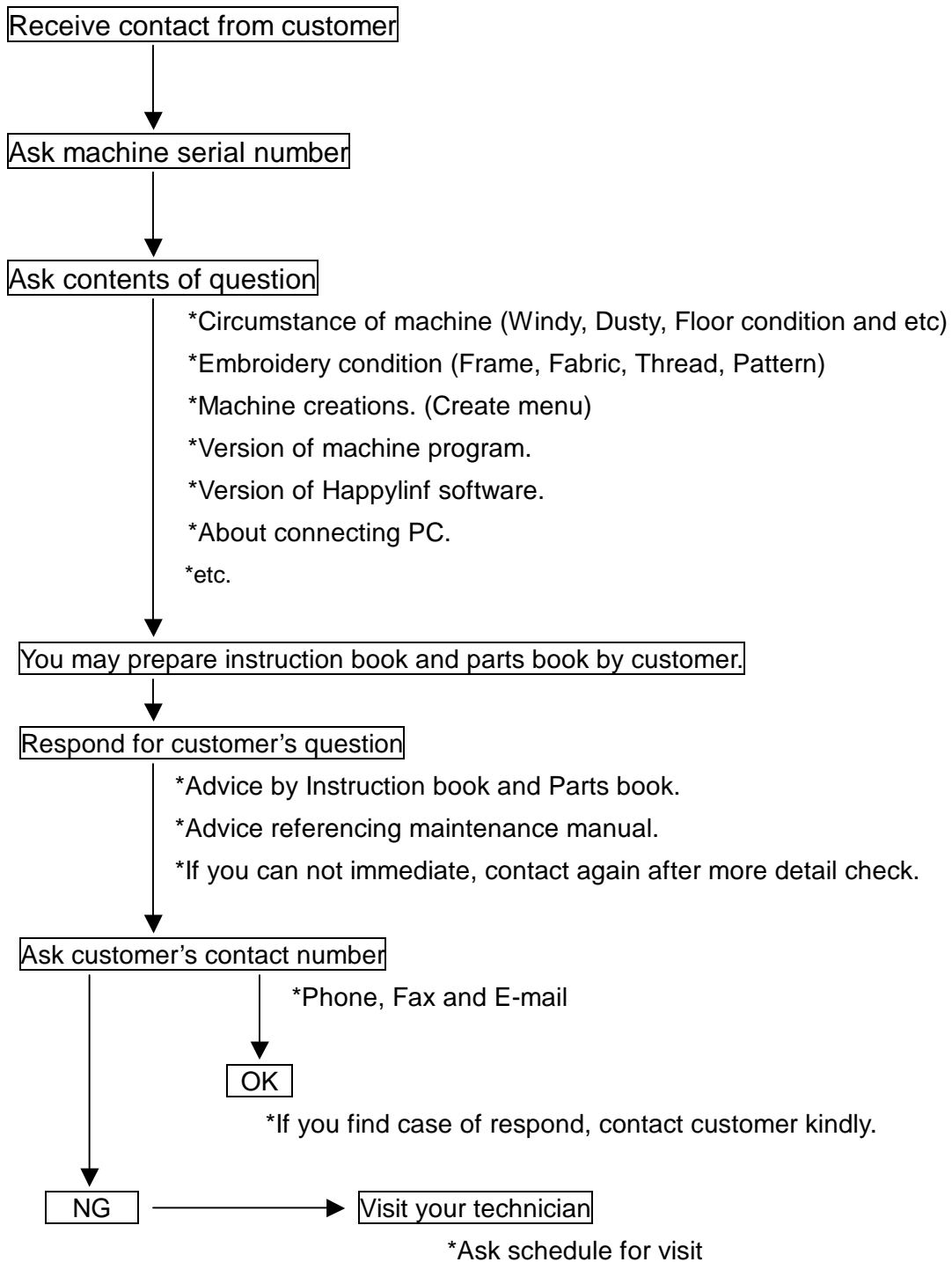

## 12-2 Trouble shooting

- 12-2-1 Electricity doesn't turn on
- 12-2-2 Thread break
- 12-2-3 Erroneous thread cut
- 12-2-4 Off-registration of pattern
- 12-2-5 Upper thread comes off from needle hole
- 12-2-6 Upper thread remains
- 12-2-7 Malfunction of thread break detection
- 12-2-8 Suspension of upper shaft
- 12-2-9 Malfunction of needle bar change
- 12-2-10 Defect on thread catcher
- 12-2-11 Others (Mechanical)
- 12-2-12 Others (Electronically)

# Trouble shooting(Electricity doesn't turn on)

12-2-1

Trouble	Factor	Cause of trouble and measure	Page
Electricity doesn't turn on	Mechanical	1. Did fuse blow? 1-1 If it did, replace it.	4-2
		2. Check of defect on board. 2-1 Replace of CPU board. 2-2 Replace of display board. 2-3 Replace of PMD board A	4-3
		3. No problem in power supply? 3-1 Check and adjust the correct voltage. 3-2 Try to replace power supply.	4-4-2, 3 4-4-1
		4. Check Volume of the power failure detection fit with PMD board A. 4-1 Adjust of power failure detection.	4-4-4
		5. Check of Cable catching causes short-circuit. 5-1 Please insulate the cable after removing outer cover. 5-2 Replace of cable.	
		6. Confirm not getting power supply from same outlet with other embroidery machine or other machines which contains motor. 6-1 Preferably only 1 embroidery machine should be connected with 1 outlet. (Maximum 2-3machines)	
	Operator	1. Didn't press emergency switch? 1-1 Release lock.	(3-8)
	Environment	1. Is electricity in receptacle? 1-1 Supply power.	

( ) ----- Reference instruction book

# Trouble shooting(Thread break)

12-2-2

Trouble	Factor	Cause of trouble and measure	Page
Thread break	Mechanical	1. Is needle drop unstable by vibration? 1-1 Reconsider where to install the machine. 1-2 Move the machine to floor fully reinforced. 1-3 Use strong table to be able to endure vibration.	(2-2)
		2. No burr or scratch in thread guide hole? 2-1 Remove burr and scratch. 2-2 Replace of thread guide.	3-1-1
		3. No problem in thread adjusting spring? 3-1 Replace spring if it doesn't spring. 3-2 If weak or broken, replace it.	3-1-1
		4. Does detecting roller make smooth turn? 4-1 Clean inside hole of bearing. 4-2 Correct so as for slit disc not to touch sensor. 4-3 Correct so as for cable not to touch slit disc. 4-4 Check cable of TC 12 Board is unconnected	3-3-12
		5. No problem in thread guide unit and thread tension ass'y? 5-1 Remove burr and scratch if appeared. 5-2 Remove lints and clean.	3-1-1
		6. Does disc on thread tension ass'y. turn smoothly? 6-1 Remove lints and clean. 6-2 Replace	3-1-1
		7. Is backlash between take-up lever and take-up crank roller not bigger? 7-1 Replace of take-up lever.	3-3-9
		8. No problem in needle holder? 8-1 Remove burr and scratch. 8-2 Make proper fixing. (direction) 8-3 Replace if thread guide is bent.	3-1-2 3-1-1
		9. No burr and scratch on needle plate? 9-1 Remove burr and scratch in needle hole. 9-2 Remove burr and scratch around needle hole on back of needle plate. 9-3 Replace it if not furbished. 9-4 If furbishing made needle hole wider, replace it.	3-1-1
		10. No problem in pressure foot? 10-1 Remove burr and scratch. 10-2 Correct bent. 10-3 Adjust height. 10-4 Replace of pressure foot. 10-5 Replace of pressure foot drive cam.	3-1-1 3-1-1 3-3-6 3-2-11 3-2-4

# Trouble shooting(Thread break)

12-2-2

Trouble	Factor	Cause of trouble and measure	Page
Thread break	Mechanical	11. No problem in rotary hook? 11-1 Clean it to remove lints. 11-2 Furbish scratch. 11-3 If backlash of bobbin case holder and outer hook grows bigger, replace them. 11-4 Replace.	3-1-1 (23-2)
		12. No problem in rotary hook retainer? 12-1 Remove burr and scratch. 12-2 Adjust position.	3-5-2
		13. No problem in needle? 13-1 Fix it properly . 13-2 Select proper size of needle to match thread thickness. 13-3 If tip of needle is warped or bent, replace. 13-4 Replace.	3-1-2 3-1-4 3-1-1
		14. No problem in bobbin case? 14-1 Remove rust and scratch. 14-2 If thread guide spring is off, replace it.	
		15. No problem in bobbin? 15-1 Remove scratch (iron bobbin). 15-2 If distorted. replace it.	
		16. Is needle bar spring not broken? 16-1 Replace it.	3-3-7
		17. Does needle bar make smooth movement? 17-1 If bent, replace it.	3-3-7
		18. No backlash in moving head? 18-1 Adjust positioning roller shaft.	3-3-3
		19. Needle doesn't drop in the center of needle hole. 19-1 Adjust positioning plate and adjust needle drop back and forth. 19-2 Adjust position of needle selection unit, then adjust needle drop right and left.	3-3-3 3-4-1
		20. Is the lowest needle position proper? 20-1 Adjust mechanical lowest needle position. 20-2 Adjust electric lowest needle position.	3-2-5 3-8-3
		21. Is needle height proper? 21-1 Adjust as specified.	3-3-63
		22. Is rotary hook timing proper? 22-1 Adjust as specified.	3-5-1
		23. Is clearance between needle and rotary hook proper? 23-1 Adjust as specified.	3-5-1

( ) ----- Reference instruction book

# Trouble shooting(Thread break)

12-2-2

Trouble	Factor	Cause of trouble and measure	Page
Thread break	Mechanical	24. Check tip of keeper hit the bobbin case. 24-1 Adjust it regularly.	3-6-8
		25. Is take-up lever timing proper ? 25-1 Adjust as specified.	3-2-9
		26. No problem in timing belt? 26-1 Adjust tension. 26-2 If scratched or damaged, replace it.	3-8-1 3-8-2
		27. Is revolution setting proper? 27-1 Make automatic speed setting.	(25-2) 10-1
		28. Is inverter setting proper ? 28-1 Make setting.	6-2
		Operator	1. Operation is wrong (no proper [Machine settings] setting for sewing?) 1-1 Tell how to operate.
	2. Is pattern dwindled too much by pattern adjustment? 2-1 Adjust size so as to produce less thread break. 2-2 Use pattern edited again (density_ change).		
	3. Is thread tension properly set? 3-1 <Upper thread> Considering sewing finish, set tension. 3-2 <Bobbin thread> Considering upper thread tension, set tension.		(8-1) (4-5)
	4. Is bobbin winding proper? 4-1 Adjusting bobbin winding tension, wind with proper strength.		(4-4)
	5. Is bobbin put in bobbin case properly? 5-1 Viewing from front of bobbin case, set so that bobbin turns left-wise.		(4-5)
	6. Does thread cone stand properly? 6-1 Keep thread from hitting felt. 6-2 Stand vertically.		(4-6)
	7. Is passing of thread proper? 7-1 Pass thread properly.		(4-6) (4-7)
	8. Is cloth properly stretched? 8-1 No loosening and no too much tightening. Even tension in depth and width. 8-2 Texture should be even in direction of X and Y.		(6-2) (7-5)
	9. Is frame properly set? 9-1 Frame should be put in positioning hole on tubular-frame. 9-2 No loosening of screw.		(6-3) (7-6)

( ) ----- Reference instruction book

Trouble	Factor	Cause of trouble and measure	Page
Thread break	Operator	10. Is frame used to suit pattern size? 10-1 Use frame to suit pattern size.	(20-1)
		11. When you dispose of thread (thread remains around rotary hook), didn't you damage rotary hook, needle plate with scissors? 11-1 Tell to dispose of thread carefully. 11-2 Open needle plate to dispose of thread.	(23-3)
		12. Didn't you neglect cleaning and oiling? 12-1 Tell to always clean and use cleanly. 12-2 Tell to oil regularly.	(23-2)
	Thread & cloth	1. Is thread used to suit needle size? 1-1 Use thread to suit needle size.	3-1-4
		2. Is thread used to suit embroidery? (thread twist, tender thread). 2-1 Don't use too strongly twisted thread. 2-2 Twist of thread is to be left-wise. 2-3 Use tender thread. 2-4 Don't use thread with knot or uneven size.	3-1-3
		3. Is thread properly wound against cone? 3-1 Use thread to be wound smoothly.	
		4. Isn't tip of cone warped or isn't thread caught in scratch? 4-1 Remove warp and scratch.	
		5. Don't use thread left for a long period? (inferior thread). 5-1 Don't buy thread more than you use. 5-2 Tell not to store thread for a long period. 5-3 Tell how to store. (direct sunshine. humidity dust etc.)	
		6. Isn't poor unwoven cloth used? Is number of sheets used proper?	
	Environment	1. Is strength of table and floor enough? 1-1 Reconsider place to install the machine. 1-2 Move the machine to place where floor is strong enough. 1-3 Use table with strength endurable against vibration.	(2-2)
		2. Are room temperature and humidity proper against thread? 2-1 It is desirable to install air conditioner to keep temperature and humidity in a certain level.	(23-1)
		3. Doesn't embroidery machine receive direct sunlight? (cause of inferior thread) 3-1 See not to expose to sunlight (spread curtain)	

( ) ----- Reference instruction book

# Trouble shooting(Thread break)

12-2-2

Trouble	Factor	Cause of trouble and measure	Page
Thread break	Environment	4. Is there something that produce steam, wasted cotton, dust around. the embroidery machine? 5-1 Keep the embroidery machine off those things.	
		5. Does thread go out of control by taking wind from outside or heater etc.? 6-1 Keep the embroidery machine off such wind. 6-2 Move the embroidery machine to proper place.	
	Pattern	1. Does thread break occur repeatedly at same place in design? 1-1 Check pattern to modify punching.	
		2. Is it too narrow between stitches? 2-1 Check pattern to modify punching. 2-2 Setting of [Reading] menu. (Stitch sweeper)	(14-4)
		3. Too many empty stitches? 3-1 Make [Reading] setting. (Skip null stitches)	(14-4)
	Others	1. Using spray paste (adhesive material) 1-1 Clean around rotary hook. 1-2 Replace or clean needle. 1-3 Use this paste at a given place and never use in front or back of the embroidery machine.	(23-2) 3-1-2

( ) ----- Reference instruction book

Trouble	Factor	Cause of trouble and measure	Page
Erroneous thread cut (E-190) (E-193)	Mechanical	1. Is thread cut timing proper? 1-1 Set timing to specified value.	3-6-1
		2. Isn't rubbing of fixed knife and moving knife weak? 2-1 Adjust to be able to rub properly.	3-6-4
		3. Does moving knife make smooth move? 3-1 Check if rubbing of moving knife and fixed knife is not too strong. 3-2 Check no loosening of screw on moving knife. 3-3 Check no damage or scratch on face of moving knife.	3-6-4 3-6-2
		4. Check Displace of moving knife. 4-1 Adjust of moving knife position.	3-6-5
		5. Check defacement of moving knife or fixed knife. 5-1 If possible, furnish with file. 5-2 Replace	3-6-4 3-6-2
		6. No backlash in up and down direction of knife drive shaft? 6-1 Check no loosening of screw on moving knife. 6-2 Check no loosening of screw on knife drive shaft.	3-6-2
		7. No backlash in fixed knife? 7-1 Check no loosening of screw on fixed knife.	3-6-4
		8. Does thread cut pulse motor work properly? 8-1 Check cable. 8-2 If trouble found in CPU board or PMD board A, replace. 8-3 If trouble found in thread cut pulse motor, replace. 8-4 Adjust of thread cut sensor position.	4-3 3-6-1
		9. Is number of revolution proper at time of thread cut? 9-1 Make automatic speed setting. 9-2 If trouble in CPU board or PMD board A, replace.	(25-2) 10-1 4-3
		10. Is there no skipped stitch? 10-1 Adjust needle depth. 10-2 Adjust clearance between needle and rotary hook. 10-3 Is height of pressure foot proper? 10-4 Is rotary hook timing proper? 10-5 Is relation between needle and thread proper?	3-3-6 3-5-1 3-2-10 3-5-1 3-1-4

( ) ----- Reference instruction book

# Trouble shooting(Erroneous thread cut)

12-2-3

Trouble	Factor	Cause of trouble and measure	Page
Erroneous thread cut (E-190) (E-193)	Mechanical	11. Check the needle bar moves up and down during thread cut. 11-1 Adjust position of jump solenoid. 11-2 Replace needle bar cushion. 11-3 Replace needle bar driver.	3-2-7 3-3-7 3-2-7
		12. Is position of keeper proper? 12-1 Adjust the fixed position regularly.	3-6-8
		13. Check the movement of keeper goes smoothly. 13-1 Readjust if it is not smooth.	3-6-7
	Operator	1. No negligence in cleaning thread cut device? 1-1 Tell to clean regularly. # It's desirable to prepare brush with soft hair and air gun.	(23-2)
		2. Is timing of thread tension proper? 2-1 <Upper thread> Considering sewing finish, set tension. 2-2 <Bobbin thread> Considering upper thread tension, set tension.	(8-1) (4-5)
	Environment	1. Are power and voltage rated and stable? 1-1 Supply rated voltage.	(23-1)
	Thread & cloth	1. Is twist of thread too strong? 1-1 Use thread with proper twist.	3-1-3
		2. No skipping by use of lots of paste? 2-1 Use small amount of paste. 2-2 Remove paste stuck to needle.	

( ) ----- Reference instruction book

Trouble	Factor	Cause of trouble and measure	Page
Off-registration of pattern	Mechanical	1. Does frame move smoothly? 1-1 Avoid curling of thread and cloth. 1-2 Reinstall of outer cover in case of touch with outer cover.	2-2
		2. Is bound of frame base too big? 2-1 Fix frame base between bearing and base without gap.	(6-1)
		3. Is carriage belt tension proper? 3-1 Adjust all belts as specified.	3-7-1 3-7-3
		4. No loosening of screws on carriage drive? 4-1 Check screw. If loosened, tighten firmly.	
		5. No lints or dust around idler pulley on carriage? 5-1 Clean	
		6. No damage in carriage belt? 6-1 If damaged, replace.	3-7-2 3-7-4
		7. No backlash of back and forth in moving head? 7-1 Adjust positioning roller shaft to remove backlash back and forth.	3-3-3
		8. Is height of pressure foot proper? 8-1 Adjust as specified.	3-2-10
		9. No problem in motion of pulse motor? 9-1 Check wiring. If screw got loosened, tighten more. 9-2 After 9-1, still problem, then replace.	
		10. No problem in motion of PMD board A ? 10-1 Check wiring. If screw got loosened, tighten more. 10-2 After 10-1, still problem, then replace.	4-3
		11. Doesn't other frame than Happy's genuine one used? 11-1 If frame is too heavy, don't use it. 11-2 If setting is not proper, set it so as not to move.	
		12. No problem in CPU board? 12-1 Try to initialize. 12-2 Replace of CPU board.	8-4-2 (25-1)
		13. Is number of revolution proper? 13-1 Make automatic speed setting.	(25-2) 10-1
		14. Not affected by noise? 14-1 Don't use the machine near where noise is generated.	
	Operator	1. Is setting of frame correct? 1-1 Frame should be put in positioning hole on tubular frame. 1-2 Set so as for screw not to loosen.	(6-3) (7-6)

# Trouble shooting(Off-registration of pattern)

12-2-4

Trouble	Factor	Cause of trouble and measure	Page
Off-registration of pattern	Operator	2. Is cloth properly stretched. 2-1 Stretch properly.	(6-2) (7-5)
		3. Is thread tension proper? 3-1 Observing sewing rhythm, set thread tension properly.	(4-5) (8-1)
		4. Was the machine left for a long time in middle of sewing? 4-1 Try to finish sewing as soon as possible.	
	Environment	1. Is strength of table and floor enough? 1-1 Check where to place the machine again. 1-2 Move to where floor is strong enough. 1-3 Use strong table to be able to endure vibration.	(2-2)
		2. No problem in pulse motor driver by low power and voltage (variation)? 2-1 Supply rated voltage. 2-2 Use transformer. 2-3 Use stabilizer.	(23-1)
		3. Is there no place where noise is generated near the machine? 3-1 Don't use the machine near where noise is generated.	
		4. Doesn't drive frame hit obstacle? 4-1 Remove obstacle. 4-2 When useing cap frame, see not to hit table.	(7-2)
	Thread & cloth	1. Not using shrinkable cloth? 1-1 Use backing paper (consider number of sheets to use).	(4-3)
		2. Isn't breakable cloth is used by thread tightening? 2-1 Use backing paper (consider number of sheets to use).	(4-3)
		3. Is proper backing paper used? 3-1 Use backing paper to match cloth.	(4-3)
		4. Isn't cloth (embroidery) too heavy? 4-1 Don't use extremely heavy cloth.	
	Pattern	1. Pattern data may be destroyed. 1-1 Read again. 1-2 Let new pattern read.	(5-4) (5-6)
		2. Memory pattern was destroyed. 2-1 Let new pattern read.	(5-4) (5-6)
		3. No problem in floppy disc or memory card? 3-1 Initialize and read again. 3-2 Prepare new floppy disc or memory card.	(21-2) (5-5)

( ) ----- Reference instruction book

Trouble	Factor	Cause of trouble and measure	Page
Upper thread comes off from needle hole	Mechanical	1. Is keeper in motion? 1-1 Check if cable was cut or there is something unusual. 1-2 In case solenoid is in trouble, replace. 1-3 In case CPU board is in trouble, replace. 1-4 In case PMD board A is in trouble, replace.	3-6-7   4-3
		2. Is keeper put in right place? 2-1 Put it as specified. 2-2 Modify bent of keeper. 2-3 Adjust it again if movement is not smooth.	3-6-9  3-6-7
		3. When thread trim action, please check upper thread wind keeper or not. 3-1 If dose not wind, please adjust keeper position again	3-6-8.
		4. Is magic-tape on thread catch holder not worn? 4-1 Replace magic-tape.	3-3-11
		5. Does bobbin thread holder hold bobbin thread? 5-1 Adjust pressure when contacting moving knife. 5-2 In case bobbin thread holder is in trouble, replace. 5-3 Clean bobbin thread holder.	3-6-6
		6. No error in thread cut (2 threads cut)? 6-1 Check and adjust thread cut timing. 6-2 Position moving knife as specified. 6-3 Check and polish burr or scratch on moving knife. 6-4 In case moving knife is in trouble, replace.	3-6-1 3-6-5 3-6-2
		7. Are clearance between needle and rotary point and needle height are proper? 7-1 Adjust clearance between needle and rotary hook as specified. 7-2 Adjust needle depth.	3-5-1 3-3-6
		8. Doesn't thread catch hook cut upper thread? 8-1 Polish burr on hook. 8-2 In case hook is in trouble, replace.	
		9. Does thread catch hook hold upper thread? 9-1 Check if cable was cut or there is something unusual. 9-2 In case pulse motor is in trouble, replace. 9-3 Adjust fixing position. 9-4 If hook is bent, modify. 9-5 In case hook is in trouble, replace. 9-6 In case CPU board is in trouble, replace. 9-7 In case PMD board A is in trouble, replace.	3-2-13    4-3

( ) ----- Reference instruction book

# Trouble shooting(Upper thread comes off from needle hole)

12-2-5

Trouble	Factor	Cause of trouble and measure	Page	
Upper thread comes off from needle hole	Mechanical	10. Check the needle bar moves when start sewing. 12-1 Adjust position to fix jump solenoid. 12-2 Replace needle bar driver.	3-2-5 3-2-4	
		11. Is number of revolution proper when sewing started? 13-1 Make automatic speed setting.	(25-2) 5-3-1	
		12. Is height of pressure foot proper? 14-1 Adjust as specified.	3-2-9	
		Operator	1. Isn't thread tension too strong? 1-1 Weaken tension not to cause trouble in sewing rhythm.	(4-5) (8-1)
	2. Keen in cleaning thread cut device? 2-1 Clean bobbin thread holder regularly.		(23-2)	
	3. Is setting of bobbin thread proper? 3-1 Pass thread on bobbin thread guide surely.		(4-5)	
	4. Is bobbin thread properly wound? 4-1 Adjust tensile strength of bobbin winder and check holding plate. 4-2 Pull out bobbin thread to check if it comes out smoothly.		(4-4) (4-5)	
	5. Is upper thread properly passed? 5-1 Pass properly again.		(4-6) (4-7)	
	6. Does thread cone stand properly? 6-1 Keep thread from hitting felt. 6-2 Stand vertically.		(4-6)	
	7. Is [Machine settings] properly set? 7-1 Select setting of length of TRD. Cut [Long]. 7-2 Select setting of Quick start mode [No]. 7-3 Select setting of STR. Lock stitch [Yes].		(5-1)	
	Thread & Cloth		1. Is thread used to suit embroidery? (thread twist, tender thread). 1-1 Don't use too strongly twisted thread. 1-2 Twist of thread is to be left-wise. 1-3 Use tender thread. 1-4 Don't use thread with knot or uneven size.	3-1-3

( ) ----- Reference instruction book

# Trouble shooting(Upper thread remains)

12-2-6

Trouble	Factor	Cause of trouble and measure	Page	
Upper thread comes off from needle hole	Environment	1. Does wind let thread go beyond control? (outside wind, heater, and fan etc.) 1-1 Keep the embroidery machine off from wind.	(23-1)	
		2. Is voltage of power as rated and stable? 2-1 Supply rated voltage.		
	Pattern	1. Is there stop sewing stitch for start sewing? 1-1 Modify pattern.		
Upper thread remains	Mechanical	1. Upper thread is difficult to come out of keeper at time of thread cut (bent or warp etc.). 1-1 Modify bent or warp. 1-2 Replace keeper.	3-6-8	
		2. Keeper doesn't return properly at time of thread cut. 2-1 Modify bent of keeper. 2-2 Adjust position to fix. 2-3 Adjust it again if movement is not smooth.		
		3. Upper thread does not come off from magic tape of thread holder. 3-1 Insert something(Thickness 0.1-0.2mm) into holder then move it right and left to put magic tape in order. 3-2 Replacement of magic tape.		3-3-11
		4. Doesn't thread catch hook cut upper thread? 4-1 Polish burr on hook. 4-2 In case hook is in trouble, replace.		
	Operator	1. Setting of thread tension is weak. 1-1 Strengthen so as not to cause trouble in sewing rhythm.	(4-5) (8-1)	
		2. Is [Machine settings] properly set? 2-1 Select setting of length of TRD. cut [Normal].	(5-1)	
	Thread & cloth	1. Using hard cloth make thread difficult to go through. 1-1 Select needle and thread.	3-1-4	
		2. Using thick cloth make thread difficult to go through. 2-1 Select needle and thread.	3-1-4	
		3. Is thread used to suit embroidery? (thread twist, tender thread). 3-1 Don't use too strongly twisted thread. 3-2 Twist of thread is to be left-wise. 3-3 Use tender thread. 3-4 Don't use thread with knot or uneven size.	3-1-3	

( ) ----- Reference instruction book

# Trouble shooting(Malfunction of thread break detection)

12-2-7

Trouble	Factor	Cause of trouble and measure	Page
Malfunction of thread break detection (empty detection)	Mechanical	1. Trouble in turning detection roller. 1-1 Clean roller shaft holder. 1-2 Check if slit disc doesn't contacts sensor. 1-3 Clean sensor if dust gets stuck. 1-4 Check if cord doesn't contacts slit disc. 1-5 Check Disconnection of cable. 1-6 Check clog of thread detection roller. Roller shaft should have clearance.	3-3-12
		2. Check circuit board. 2-1 Replace of CPU board. 2-2 Replace of TC 12 board. 2-3 Replace of PMD board A.	4-3
		3. Sometimes needle bar doesn't work when start sewing. 3-1 Replace of needle bar driver. 3-2 Adjust of jump solenoid position. 3-3 Clean and overhaul of Jump solenoid. 3-4 Replace of Jump solenoid.	3-2-6 3-2-7 3-2-14
	Operator	1. No thread is passed through detecting roller. 1-1 Pass thread properly.	(4-7)
		2. Is thread tension proper? 2-1 Observing sewing rhythm, adjust thread tension properly.	(4-5) (8-1)
		3. Is proper detection sensitivity of thread cut selected? 3-1 Select detection sensitivity according to sewing condition of thread and cloth etc.	(5-1)
	Environment	1. Is there any device to yield lints etc. around the embroidery. 1-1 Keep it off the embroidery machine. 1-2 Move the embroidery machine to other place.	
		2. Doesn't thread go beyond control by wind? (thread comes off from needle hole by losing) 2-1 Keep thread off wind. 2-2 Move the embroidery machine to other place.	
	Thread & Cloth	1. Isn't silicone agent used on thread? (Thread slips at detecting roller part due to adhere of silicone.) 1-1 Clean silicone agent attached to detecting roller groove.	

( ) ----- Reference instruction book

# Trouble shooting(Malfunction of thread break detection)

12-2-7

Trouble	Factor	Cause of trouble and measure	Page
Malfunction of thread break detection  (not detected) (slow detected)	Mechanical	1. Check circuit board. 1-1 Replace of CPU board. 1-2 Replace of TC 12 board. 1-3 Replace of PMD board A.	4-3
	Operator	1. Is thread tension proper? 1-1 Observing sewing rhythm, adjust to proper thread tension. (Adjust it little bits stronger.)	(4-5) (8-1)
		2. Is proper detecting sensitivity of thread cut selected? 2-1 Please check [TRD. break detect] in setting menu to except [Off]. 2-2 Select detection sensitivity of thread cut according to sewing condition of thread and cloth etc.	(5-1)

( ) ----- Reference instruction book

# Trouble shooting(Suspension of upper shaft)

12-2-8

Trouble	Factor	Cause of trouble and measure	Page
Suspension of main shaft (E-18) (E-51) (E-52)	Mechanical	1. Upper thread twine round rotary hook or rotary hook retainer. 1-1 Get rid of it.	(23-2)
		2. Check return of keeper goes smooth. (when start sewing, thread cutting. 2-1 Adjust it regularly.	3-6-8
		3. Check upper thread is sticking at thread guide part of bobbin case. 3-1 Get rid of it. 3-2 Do not use of bobbin case in which thread guide is coiled type. (use standard type)	(23-2)
		4. Effect by breakage of parts. 4-1 Repair broken place.	
		5. No damage in electric parts? 5-1 Replace of CPU board. 5-2 Replace of Timing Board. 5-3 Replace of inverter. 5-4 Replace of PMD board A.	3-8-3 4-3
		6. Trouble of software in CPU circuit board. 6-1 Initialize, then make automatic speed setting.	8-4-1 (25-1) (25-2)
		7. Trouble in control of number of revolution. 7-1 Make automatic speed setting.	10-1 (25-2)
	Operator	1. Isn't foreign stuff such as thread or cloth caught in where revolution is driven. 1-1 Get rid of foreign stuff. 1-2 Stretch properly.	(6-2) (7-5)
		2. Isn't thread tension too strong (stop at time of action of thread cut)? 2-1 Weaken tension so as not to cause trouble in sewing rhythm. 3. Check condition of lubrication. 3-1 Lubricate (refer to message)	(4-5) (8-1)
	Environment	1. Check adequate level of voltage (refer to trip of inverter). 1-1 Supply rated voltage. 100V – 115V -10V / +15V 200V – 230V -10V / +10V	(23-1)

( ) ----- Reference instruction book

# Trouble shooting(Malfunction of needle bar change)

12-2-9

Trouble	Factor	Cause of trouble and measure	Page
Head does not move (E-021) (E-022)	Mechanical	1. Check lint or cloth is seized between Lower Moving rail and Bearing. 1-1 Remove seized lint or cloth.	
		2. Check lint or waste is seized in gap of Moving Cam. 2-1 Remove seized lint or waste.	
		3. Effect by breakage of parts. 3-1 Repair broken place.	
		4. No problem in PMD board A. 4-1 Replace of PMD board A.	
	Operator	1. Check Stopper of Moving Head is removed. 1-1 Remove Stopper.	
Uncontrollable Move (E-024) (E-025)	Mechanical	1. No problem in sensor circuit board ? 1-1 Clean dust attached to sensor. 1-2 Replace sensor circuit board.	4-2-3
		2. Trouble in potentiometer. 2-1 Replace	3-4-2
		3. Needle number is not exactly recognized. 3-1 Recognize needle number with maintenance mode.	9-2
		4. Breakage of Pulse Motor . 4-1 Replace Pulse Motor.	

( ) ----- Reference instruction book

# Trouble shooting(Defect on Thread catcher)

12-2-10

Trouble	Factor	Cause of trouble and measure	Page
does not catch thread	Mechanical	1. Thead catcher does not extend hook sufficiently. 1-1 Adjust position of Thread catcher 1-2 Adjust position of Thread holder.	3-2-12. 3-3-10
		2. Excessive distance between Hook and tip of Needle. 2-1 Adjust position of Thread catcher. 2-2 Adjust position of Thread holder.	3-2-12 3-3-10
		3. Check Hook of Thread catcher bent or not. 1-1 Repair bent Hook. 1-2 Replace Hook.	
		4. Check position of Thread catcher is proper. 2-1 Adjust	3-2-12
Hook of Thread catcher does not extend	Mechanical	3. Check position of Thread holder is proper. 3-1 Adjust	3-3-12
		4. Check Thread catcher. 4-1 Check cable is securely connected. 4-2 Replace Pulse Motor with trouble.	
		5. No damage in electric parts? 5-1 Replace CPU Board. 5-2 Replace of PMD board A.	4-3
		1. Check Hook is bent or not. 1-1 Repair bent Hook. 1-2 Replace Hook.	
		2. Check position of Thread catcher is proper. 2-1 Adjust	3-2-12
Hook hits or catches Needle (E-193)	Mechanical	3. Check position of Thread holder is proper. 3-1 Adjust	3-3-10
		1. Check if Needle is securely set. 1-1 Set Needle properly.	(4-1) 3-1-2
		Operator	
	Constant display of E-193	Mechanical	1. Trouble of Photo sensor. 1-1 Replace Photo sensor.

( ) ----- Reference instruction book

Trouble	Factor	Cause of trouble and measure	Page
Needle Breakage	Mechanical	1. Check Needle is not bent. 1-1 Replace bent Needle.	(4-1) 3-1-2
		2. Check Moving Head set securely. 2-1 Adjust Positioning Roller Shaft.	3-3-3
		3. Secure adequate distance between Needle and Rotary Hook. 3-1 Adjust distance properly.	3-5-1
	Operator	1. Is thread method in proper way? 1-1 Threading again in a proper way.	(4-7)
		2. Check upper thread comes in a smooth way. (Thread stand, Thread tension point, double back etc) 2-1 Adjust place be caught in.	(4-7)
		3. Check whether fabric is fixed firmly or not. 3-1 Hooping fabric firmly again.	(6-2) (7-5)
Defect of pressure foot movement	Mechanical	1. Check whether pressure foot and thread catcher holder touch each other or not. 1-1 Adjust installment position of thread catch holder. 1-2 In case pressure foot is fixed at an angle, fix it vertically again.	3-3-10 3-2-11
Abnormal noise	Mechanical	1. By defect of cover installation. (Pressure foot drive, Carriage etc) 1-1 Take care of insert condition, clearance etc and fix again.	
		2. By lack of oil inside rotary hook. 2-1 Refuel 2-2 Replace of rotary hook	(23-1) 3-5-1
Big noise	Mechanical	1. Bearing gap of take up crank ass'y. 1-1 Adjust roller shaft ass'y. 1-2 Replace of roller shaft ass'y.	3-2-8
		2. Gap between take up lever ass'y and take up clank ass'y. 2-1 Replace of take up lever ass'y. 2-2 Replace of take up lever crank ass'y	3-3-9 3-2-1
		3. Needle bar driver gap of needle bar driver ass'y. 3-1 Replace of needle bar driver ass'y.	3-2-6
		4. Gap between Crank ass'y and Rod ass'y. 4-1 Replace of crank ass'y. 4-2 Replace of rod ass'y	3-2-1 3-2-2
		5. Big gap pressure foot cam 5-1 Replace of take-up lever cam.	3-2-4

( ) ----- Reference instruction book

Trouble	Factor	Cause of trouble and measure	Page
Frame overrun	Mechanical	1. Interference between censor circuit board and douser. 1-1 Position adjustment of douser. 1-2 Replace of censor circuit board.	
		2. Check whether cable has problem or not. 2-1 Replace in case damage exists. 2-2 Insert connector again.	
		3. No damage in electric parts? 3-1 Replace CPU Board. 3-2 Replace of PMD board A.	4-3
Key on control box can not be pressed down and returned	Mechanical	1. When removing panel in replacing circuit board , due to poor cable bundling, circuit board being pushed from inside. 1-1 Bundle cable again	5-1-1
Defect of LCD	Mechanical	1. Check LCD . 1-1 Replace of LCD	5-1-2
		2. Inadequate condition of cable insertion 2-1 Insert to the back firmly	5-1-1
		3. Check whether CPU board is out of order or not. 3-1 Replace of CPU board	
Defect of data communication (E-90) (E-91)	Mechanical	1. Check whether cable is insert firmly between CPU Board and serial board or not. 1-1 Insert again	
		2. Check whether PC has problem or not. 2-1 Affirm whether there is problem or not.	
		3. Check serial circuit board is out of order or not. 3-1 Replace of serial circuit board.	
		4. Check whether CPU circuit board is out of order or not. 4-1 Replace of CPU board.	
	Operator	1. Baud rate does not fit between machine side and PC side. 1-1 Make setting of baud rate	(5-1) P19-P20
Pattern disappears / Watch doesn't indicate time	Mechanical	1. Trouble in back-up battery 1-1 Replace CPU board.	
		2. No trouble in memory tip on CPU board? 2-1 Conduct [memory all clear] in maintenance mode. 2-2 If above measure doesn't solve the trouble, replace CPU circuit board.	9-3

( ) ----- Reference instruction book

P\*\*-P\*\* --- Refer to Happy Link instruction book

## 12-3 Error

12-3-1 Error and measure

When trouble occurred while the machine is running, error number and error item will be displayed. After confirming contents, press button [SET] on control box to release error, then restore in accordance with measure in this list.

No.	Message	Error	Measure	Page
001	Circuit board	Trouble detected in control circuit board.	(1)Turn power off once and turn on again. (2)If recurred, replace CPU circuit board.	
002	Power source	Power failure or abnormal voltage	Replace CPU circuit board.	
004	System memory	Trouble in system memory.	Replace CPU circuit board.	
014	Fan Alarm	Cooling fan fault	(1)Clean dust attached to fan. (2)Replace fan.	4-5
015	Inverter trip	Trouble in drive unit on main shaft. Overload on main shaft motor, damage in drive unit on main shaft.	(1)Turn power off, turn main shaft by hand and if no trouble found, turn power on again. (2)If trouble found, repair where damaged. (3)If inverter in trouble, replace. (4)Check if voltage high or not. If high,check origin of power source of factory. Or use stabilizer, transformer to set to rated voltage.	6-1-1
016	Alarm X unit	X-motor-related trouble, i.e. x-motor overload, short circuit, problem with motor drive unit	(1)Power off machine, test pantograph movement manually. Check for any abnormality throughout full range of motion. If none found, power on again. (2)Check related harness. (3)Replace drive-A circuit board.	4-3
017	Alarm X unit	Y-motor-related trouble, i.e. y-motor overload, short circuit, problem with		
018	Main shaft	Suspension of main shaft in mid way.	(1)Check if trouble found between main shaft and drive. If trouble found, restore. (2)If recurred, find cause and fix. (3)Make automatic speed setting again.	10-1
020	Needle detect	Needle position not detected. Trouble in stop position of needle selection unit.	(1)Turn needle selection cam by hand to set to regular position. (2)Fix needle selection related mechanical trouble. (3) Replace sensor circuit board or potentiometer.	3-4-2
021 022	Needle move	Suspension of needle selection motor in mid way. Trouble in take-up lever hinders. Trouble in position detecting circuit board.	(1)Turn needle selection cam by hand to set to regular position. (2)Fix needle selection related and take up lever related troubles. (3)Replace sensor circuit board or potentiometer.	3-4-2

( ) ----- Reference instruction book

No.	message	Error	measure	page
024	Needle center	Stop position of needle bar is off center	(1)Turn needle selection cam by hand to set to regular position. (2)If trouble occurs repeatedly, fix mechanical trouble in needle selection & its vicinity.	
025	Needle over	Specified needle number went beyond needle number of the machine.	Adjust position of needle selection cam (potentiometer) and needle number of moving head.	3-4-3
026	Needle differ	As needle number differed from memory when power turned on, it was renewed.	(1)Turn power off once and turn on again. (2)Let the machine recognize needle number.	3-4-3
030	Slow mismatch	Inadequate adjustment of number of low speed revolution. Low speed revolution doesn't come below 100rpm.	(1)Make automatic speed setting. (2)If not solved even after speed adjustment, replace CPU circuit board.	10-1 (25-2)
050	C point	Main shaft stops off its position.	(1)Turn main shaft to plus direction to set to C point.	(24-1)
051	L sensor	Poor lowest needle position sensor on timing detecting circuit board. Damage in timing detecting circuit board, stained photo sensor, poor adjustment of slit disc.	(1)If photo sensor is stained, clean. (2)Adjust timing. (3)Replace main shaft timing circuit board.	3-8-4
052	C sensor	Damage in color change point sensor on timing circuit board. Damage in timing detecting circuit board, stained photo sensor, poor adjustment of slit disc.		
060	X limit	Drive frame went beyond limits in X direction.	(1)Move drive frame back to limits with move key. (2)Correct pattern size and setting contents.	
061	Y limit	Drive frame went beyond limits in Y direction.		
066	Frame drive	Frame movement did not complete during origin point movement.	(1) Dirt L point sensor [PH1] or wrong position of slit. (2)Replace timing circuit board.	3-8-4 3-8-3
067	L sensor	Consumption of embroidery frame coordinate data.	Adjust position sensor position on carriage. Then register frame position again.	9-6
068	Position set	Failure to read embroidery frame sensor signal. (Return)	(1)Check if position sensor is dirty. Turn off power source, then turn on again. (2) Replace position sensor circuit board.	9-6
069	Position Entry	Failure to read embroidery frame sensor signal. (Entry)		

( ) ----- Reference instruction book

No.	message	Error	measure	page
070	Safety sensor	Safety sensor has been tripped.	(1)Clear area around safety sensor. (2)Check material dose not shut out safety sensor beam. (3) Adjust safety sensor position.	7-3-3
090	Miss reception	Error has occurred during data transfer (via cable) between machine and PC.	(1)Let the machine read pattern data from first. (2)Set transmitting speed of the machine and personal computer.	(5-4)(5-6) (5-1)
091	No send	Data is not put in for over 10 seconds.	Let the machine read data from first.	(5-6)
103	Data format	Machine unable to determine format of pattern data.	(1)Check format of pattern data. (2)By setting reading of pattern data,	(14-4)
104	Miss function	Timing to read pattern data doesn't conform.	Read pattern data again from the first.	(5-4)(5-6)
105	Dual function	One stitch data has more than 2 functions.	(1)Read pattern data again from the first. (2)Check and modify the design data if there is wrong.	(5-4)(5-6)
106	No function	Interval between start read time and time of reception of actual pattern data	Read pattern data again from the first	(5-4)(5-6)
108	Improper read	While reading pattern data, there accrued error in internal processing.	Read pattern data again from the first.	(5-4)(5-6)
110	Memory full	While reading pattern data, memory exceeded its capacity.	(1>Delete unnecessary patterns and read from the outset. (2) Put additional memory (Option).	(5-B) 7-2
111	Change over	While reading pattern data, the frequency of color change (color No.) exceeded 250 times.	(1)Modify pattern data and reduce frequency of color change of one pattern to less than 250 times. (2)Divide pattern data and reduce frequency of color change of one pattern to less than 250 times.	
112	Data error	Pattern data of pattern to be embroidered is damaged.	(1)Read pattern data again from the first. (2)Read pattern data again if you have a backup data.	(5-8)
114	Id over	The number of pattern in memory has reached maximum of 99.	Delete unnecessary patterns and read.	(5-B)
116	Not found Id	Specified pattern does not exist.	(1)Check setting. (2)Re-initialize machine system.	(25-1)
118	Trace data over	The stitch number counts over 1024 stitches during preparing Trace data.	Set Embroidery area of pattern data within 2m(X) x 2m(Y).	
120	Memory error	It became impossible to retain contents of memory.	(1)Turn power off once and turn on again. (2) If problem recurs frequently, replace CPU board assembly.	

No.	message	Error	measure	page
130	Disk error	Unable to communicate continuously with memory card or data disk.	(1)Turn off power source once and turn it on again. (2)Memory card reading processor may defective. Replace the circuit board.	
131	Device no ready	Memory card or data disk is not set.	Check if memory card or data disk is properly set.	(5-5)(5-8)
132	Write protect	Disk write protected	Disable write protect on disk.	(2-5)
133	Bad disk	Improper or faulty data disk or data disk.	(1)Memory card oor datadisk might be not readable with the machine. Prepare readable memory card or data disk for the machine. (2)Memory card or datadisk might be defective. Prepare another memory card or data disk which is not defective. (3)Initialize the memory card if it is not initialized.	(5-5)(5-8)
134	Disk unit	Trouble in disk drive unit.	(1)Turn off power source once and turn it on again. (2)If error remains, there is a problem with the disk drive unit.	
140	Entry over	Maximum number of patterns has been exceeded.	Clear unnecessary patterns or use alternate disk.	(21-1)(21-2)
141	Not found name	Designated pattern is not found.	Memory card might be not readable with the machine. Prepare readable memory card for the machine.	(5-5)
142	Disk full	Disk is full to capacity.	Clear unnecessary patterns or use a different data disk.	(21-1)(21-2)
143	Multi name	Another pattern with same name has been detected while attempting to write to disk.	Change name, use a different disk, or overwrite existing pattern.	
190	Cut blade	Thread cut knife is not at stop position.	(1)Restore the moving knife to stop position. (2) Check dirt of trim sensor or position of slit. (3)Modify the adjustment if the problem repeats. (4) Adjust sensor position.	(24-6)
193	Catcher	Thread catch hook is not in its stop position.	(1)Check if mistake is found in thread cut. If found, cut thread and move thread catch hook to proper position. (2)Adjust and correct trouble that hinders motion of thread catch hook.	(24-8)

No.	message	Error	measure	page
215	Frm. drive err	Frame movement did not complete. during normal movement. (Time over)	(1) Check timing sensor unit and slit. (2) Install Frame moving data.	
217	Frm.drive data	Frm.drive data	Install Frame moving data.	
220	Calendar Stop	Calendar has not been setup.	Set calendar data after re-starting machine. If problem recurs frequently, replace CPU board assembly.	(3-7)
221	Battery Low	Low voltage warning for CPU board battery.	If machine has not been powered on for an extended period, CPU board battery drains. Power on machine and if problem persists, replace CPU board assembly.	
222	Calendar Data	Incorrect calendar data. been exceeded.	Please set calendar date and time. If you have same problem often, please replace CPU board assy'.	(3-7)

( ) ----- Reference instruction book

## 12-4 Reference date

12-4-1 Tables for timing / adjustment value

		Tables for Timing/Adjustment value
Take-up lever timing		0 degrees
Rotary hook timing		23 degrees
Needle height		5 degrees
Main shaft timing	L	LED4 light out at 0 degrees(Clockwise)
	C	LED3 light on at 270-284 degrees(Clockwise)

Maintenance Manual for Embroidery Machine

HCD-1501-40

2006 / 1



**HAPPY Industrial Corporation**

9-5. TAITO 2-CHOME, TAITO-KU, TOKYO, JAPAN

TEL +81-3-3834-0711

FAX +81-3-3835-8917