



Training:

HAPPY HCS-1201 Voyager Operations & Maintenance **For Voyager, Color Monitor with Firmware v1.14**

Chapter 2: MACHINE SETUP & ORIENTATION

– Proper Machine Setup

- Machine environment *page 2*
- Upper threading *page 3*
- Bobbin threading & Tensioning *page 5*

– Control Panel 2

- Sewing controls, what your machine is telling you on the main screen *page 6*
- Frame screen: key functions accessed in the frame menu *page 9*
- 6 Important Main Menu functions in detail: Pattern, Setting, *page 10*
Needle, Read, Frame, Position

– Transferring Designs into the machine, detailed steps

- Transfer by USB cable connection from a PC *page 27*
- Transfer by Compact Flash or USB jump drive *page 31*

Proper Machine Setup: Environment

Temperature and Humidity-Controlled Environment

Set up/store your machine in a temperature and humidity-controlled environment to prevent long-term corrosion and to protect the electronics. Don't keep your machine anywhere you wouldn't keep a laptop or desktop computer !

Clean, Protected Electrical Power

grounded outlets: Your machine uses standard 110v household current. Be sure you connect it to a grounded 3-prong outlet like the one shown here. This is standard in most homes and businesses today, but some older buildings may only have 2-prong outlets.



Standard
3-prong
110v
outlet



Basic surge
protector

surge protection: Protect your machine against occasional power spikes (from electrical storms or electrical wiring problems) with at least a basic surge protector. The electronics on your machine can be very expensive to replace. Higher-end surge protectors and UPS units are able to protect against higher energy strikes, and often come with a guarantee.

Steady Table / Mounting Surface

Your machine will perform better (especially at higher speeds) when operated on a strong, level and steady mounting surface. Although on wheels, the optional stand provides plenty of stability, and even more when the wheel brakes are applied at all 4 corners.



Optional machine stand with accessory
shelf, casters and wheel brakes

Proper Machine Setup: Upper Thread

UPPER THREAD

-Proper Thread Routing: All threads **must** be routed correctly at all points along the path through the sewing head.

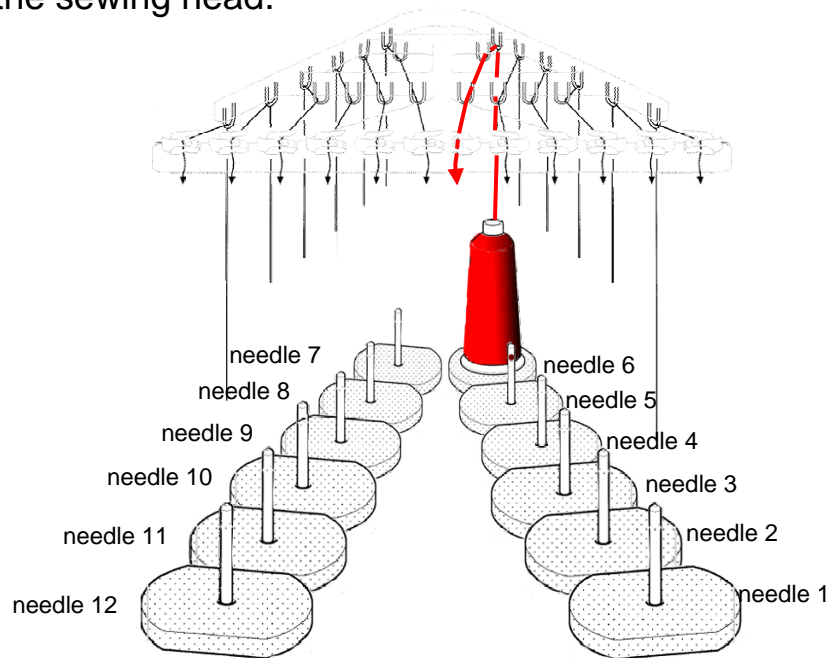

Layout of Cone/Needle Sequence

Needle numbers are arranged right to left, lowest number to highest.

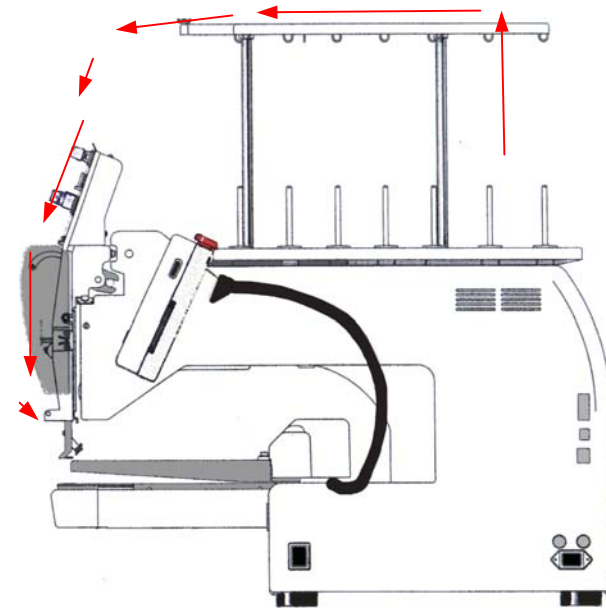

General Thread Route

Thread must pass up from cones through guide holes in thread tree and through every specific point along the face of the sewing head. Thread must be "docked" at the thread holder spring.

Proper Machine Setup: Upper Thread

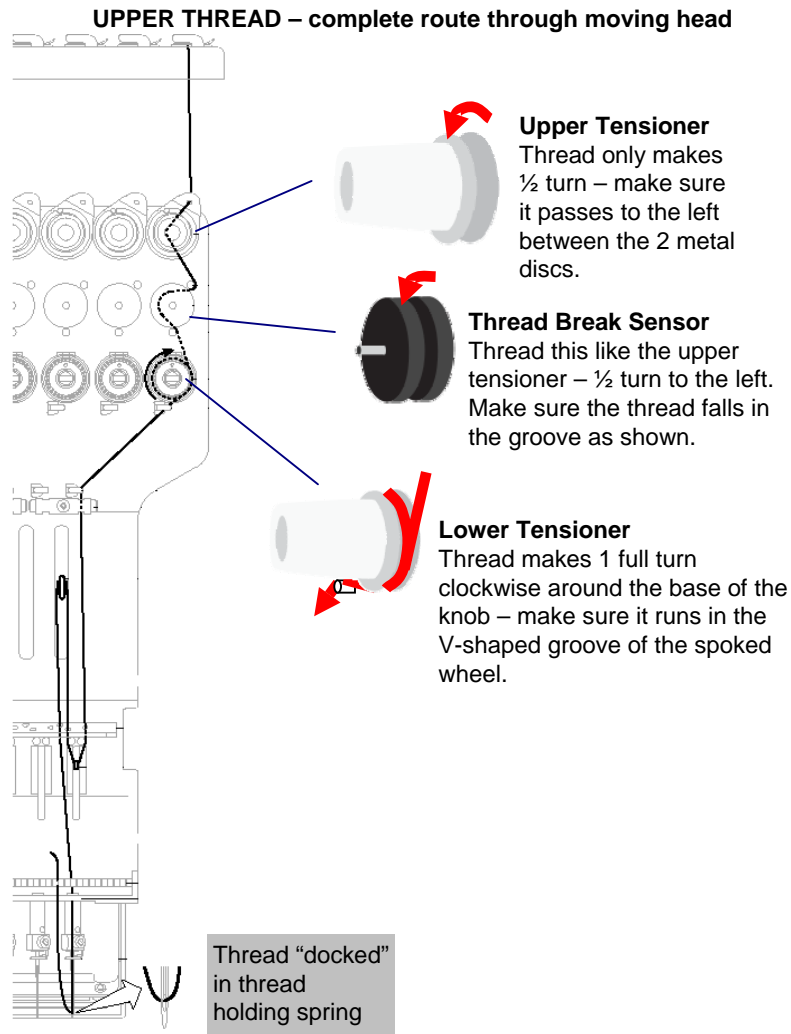

-Proper Thread Routing: All threads **must** be routed correctly at all points along the path through the sewing head.

-Practice good thread “Discipline”: After threading all needles, ensure there is no slack anywhere along the thread path. Make sure to:

-Pull all threads – to ensure thread feeds smoothly and turns the break sensor, and all slack is removed from around thread cones

-“Dock” all thread ends from each needle onto the thread-holding spring. Prevents thread from coming loose and catching where not desired.

Proper Machine Setup: Bobbin loading and Tension check/ adjustment

Machine Setup

Control Panel 2

Design Transfer

RE-LOADING THE BOBBIN CORRECTLY

The bobbin will need to be replaced frequently, allowing only 30,000 to 60,000 stitches per spool. This has to be done correctly every time.

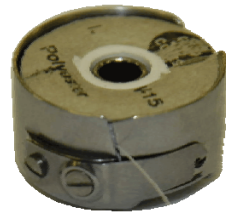

1. Ensure bobbin turns clockwise. Pull thread through this slit.



2. Feed thread through eye at the end of the tension flap.



3. Pass thread under wire loop at the top front of the bobbin case.

CHECKING TENSION

- **The “yo-yo” test** is very exact in checking tension. Perform this quick check each time you re-load the bobbin. Practice until you are comfortable doing this.
- **Check bobbin tension frequently** when changing bobbins.

TAKE CARE TO RE-INSERT THE RELOADED BOBBIN CASE FULLY!

Your machine will not sew any stitches unless this is done. At worst, the needle & needle bar may strike the side of a poorly-inserted bobbin case, breaking the needle and possibly putting needle depth out of adjustment for that needle.

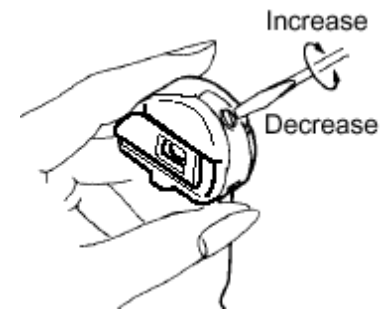

Make small adjustments

– no more than a $\frac{1}{4}$ or $\frac{1}{2}$ turn in either direction before re-checking tension.

Sewing Controls

Basic Sewing Controls

On this page, learn the function of the important sewing controls.

Color Code

Items in **black** – function only when machine is stopped.

Items in **red** – function when machine is running or stopped.

• Sewing Controls

Understand the functions of these key sewing controls.

P.FOOT lowers the presser foot on command

TRACE only traces when design is at Origin. Does slow trace when held continuously.

FWD advances sewing position forward while machine is stopped.

CUT cuts current thread and tucks end into thread holder.

START starts sewing. Bypasses trace. Sews in “creep” mode when held down.

STOP stops sewing. Also when stopped moves sewing position backwards. Useful after thread breaks.

Needle Select Keys change the currently-selected needle while machine is stopped.

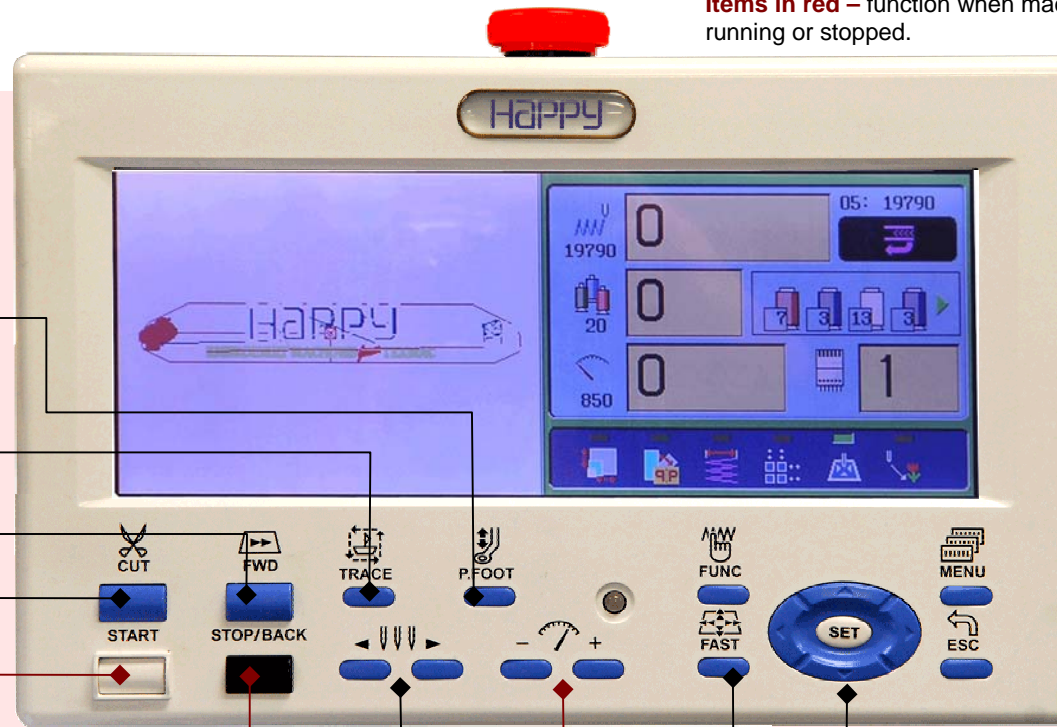

Speed control – adjusts max sewing speed.

Sewing arm movement move pantograph arm with the 4 blue arrow keys, hold FF at same time for quick movement

Main Screen Information

Information Display

Important information about design & sewing status

of Stitches in design
current stitch position in design

Total # of color blocks in the design
current block #
next 4 colors in sequence

origin indicator – indicates that sewing position is at the design origin, before the trace.

Max allowed speed – set this with the + and – keys up to 1000 spm.

Actual sewing speed – machine sews at speeds up to max allowed speed, but varies according to stitch length. Longer stitches take more time, requiring a slower speed.

Active needle: shows the currently selected needle #

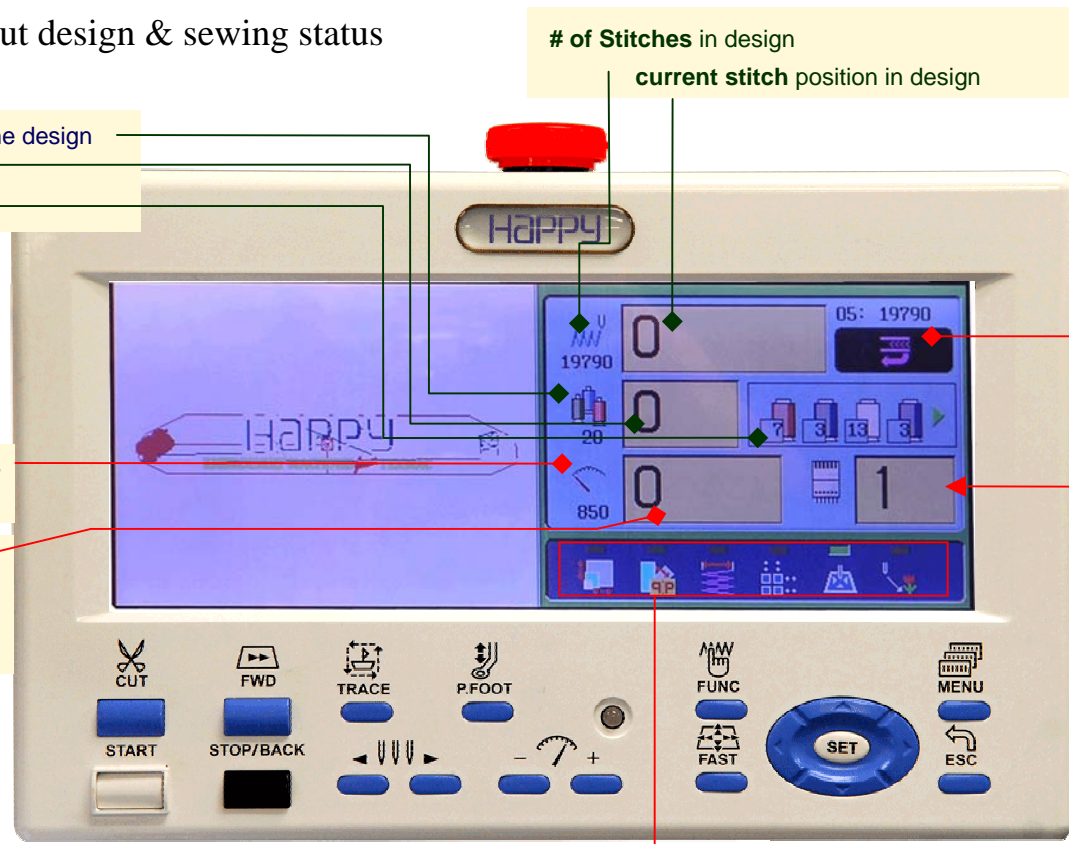

Indicator lights: serve as reminders for any edits that may have been done to the design from the control panel (in order from left to right, scale, rotate, satin pull compensation, repeat, auto origin return, offset)

General Tips in Navigating Main Menu Screens

In many of the screens accessed from the main menu, there are additional options that can be accessed in the same way. In the sample screen shown below, we've illustrated a few simple rules:

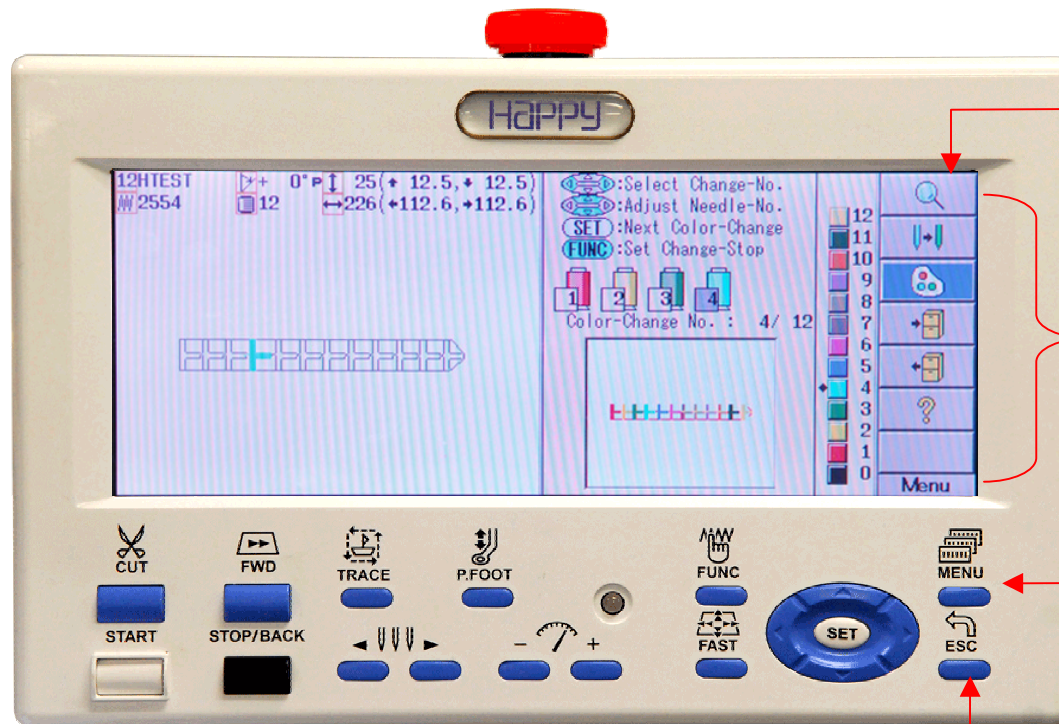

View Design: This option displays the design full-screen with any current changes you've made to it.

Sub-menu: Contains additional options for a given screen.

Press MENU to access the sub-menu. You'll see the uppermost icon highlight in blue.

Press ESC to exit the sub-menus and return the cursor to the rest of the Needle screen (example shown here)

The Function Screen

The FUNC menu allows quick access for key machine functions directly in the main drive screen.

O SET sets the design origin point at the current hoop position.

TOP positions the hoop at the top of the pattern. Repeating returns hoop to previous position.

ORIGIN: resets sewing position to the start. Does not change position in hoop.

LOG-IN: Set this to log the machine on to a Happy machine network.

TURN-OFF: Always try to power down the machine from this option, not at the power switch.

FRAME POSITION displays the submenu menu shown. Functions are shown below.

Access this menu by pressing the FUNC key.

CENTER centers the hoop.

FRAME OUT

CENTER DESIGN in the hoop.

POSITION moves hoop to current stitch position.

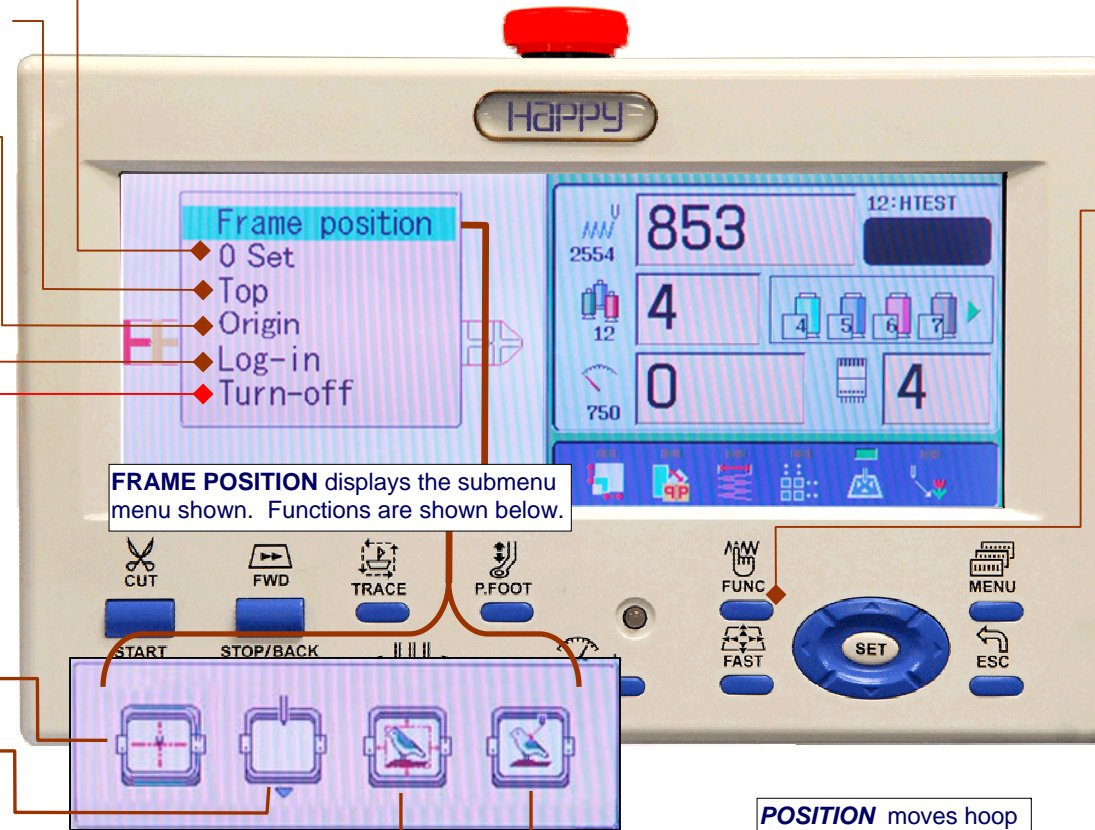

The 6 Important Main Menu Screens

Important Main Menu Features

The options on the first page of the main menu have the most important, useful functions.

Needle Screen is most important – for assigning thread colors to the design.

Read Screen is for read designs from a compact flash card or USB jump drive.

Setting Menu allows you to make useful adjustments to the design.

Pattern Menu: select, organize, delete designs, or save back to flash memory device

Position Function lets you jump to different parts of the current design

Frame Function allows you select a hoop and adjust fit/position of the current design in that hoop. Allows the user to input custom hoops or frames.

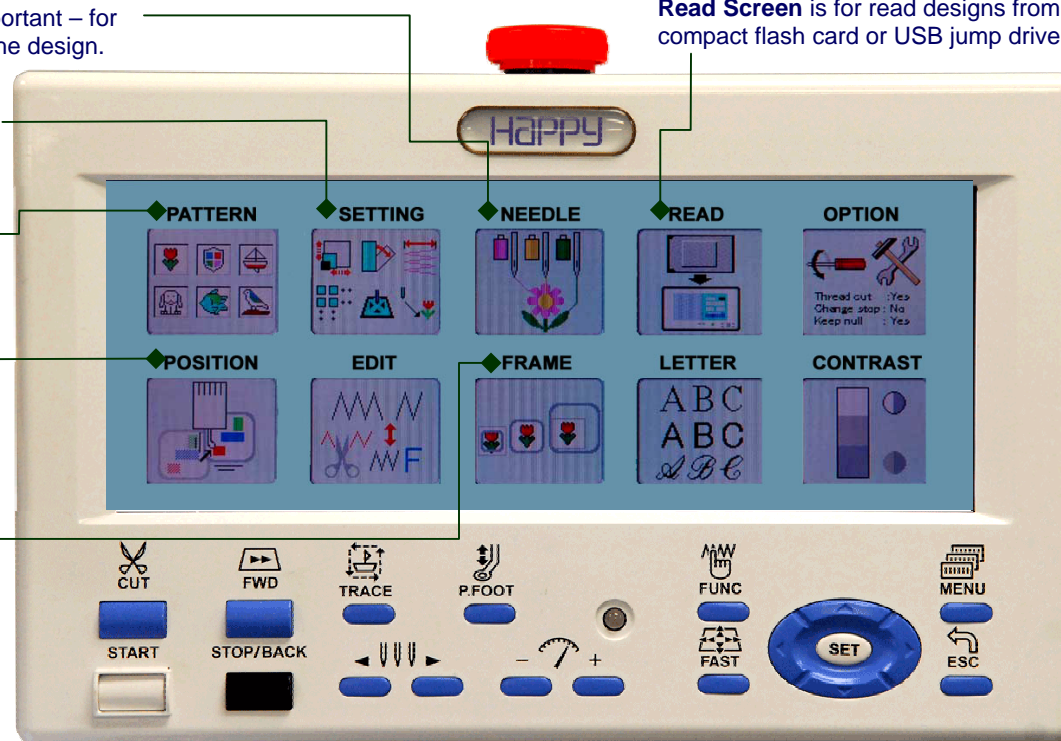

Important Main Menu Screens: Needle Screen

Designs sew in a sequence of **color blocks**. In order that your machine sews each color block with the correct color in the correct order, you can set that color sequence in the Needle screen, shown here.

First match the thread color palette to the actual thread colors installed on the machine. You'll only need to do this once for all colors, then only for any time you replace thread cones with other cone colors.

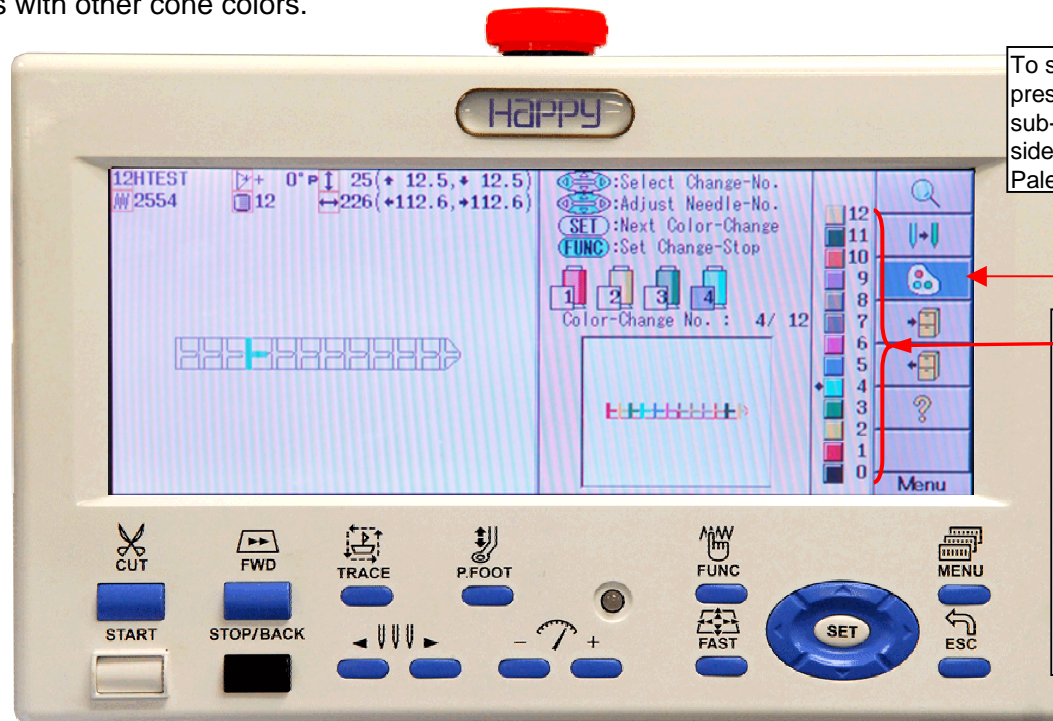
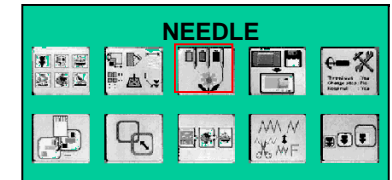

To set the color palette, press MENU to access the sub-functions on the right side, then arrow down to the Palette icon.

Thread color palette: lets you tell the machine which thread color is assigned to a given needle. When properly matched, it allows a color-accurate preview of the design colors that will actually sew.

NEXT: THE COLOR PALETTE

Important Main Menu Screens: Needle Screen

Designs sew in a sequence of *color blocks*. In order that your machine sews each color block with the correct color in the correct order, you can set that color sequence in the Needle screen, shown here.

First match the thread color palette to the actual thread colors installed on the machine. You'll only need to do this once for all colors, then only for any time you replace thread cones with other cone colors.

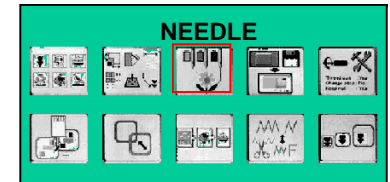

How to Change the color assigned to each needle: Use the blue arrow keys to move the pointer to the needle whose color you wish to change. Then, press SET, calling up a color palette. Use the arrow keys to choose a different color and finally press SET.

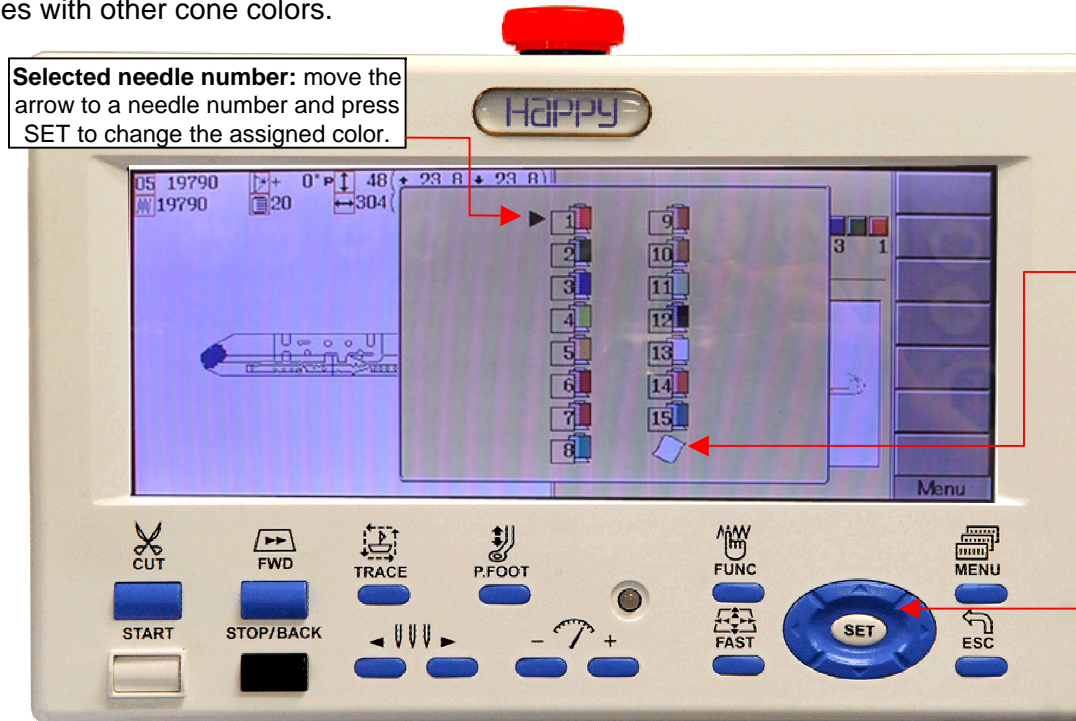

NEXT: HOW TO SET THE COLOR SEQUENCE

Important Main Menu Screens: Needle Screen

Designs sew in a sequence of *color blocks*. In order that your machine sews each color block with the correct color in the correct order, you can set that color sequence in the Needle screen, shown here.

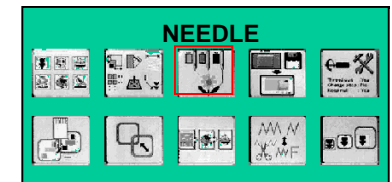

Only 4 color blocks show in the list. To navigate to other color blocks, press the left or right arrow key to shift and show color blocks earlier or later in sequence.

Appliqué: Pressing the FUNC key when the arrow is next to a particular color block sets a stop command (marked by an asterisk *) causing the machine to sew that color and stop before continuing.

1. Select the color block # you wish to edit using the left or right arrow keys.

2. The selected color block will highlight to help confirm the part of the design you're setting the color for.

3. Change the needle number by using the up/down arrow keys. Up increases, down decreases the value.

4. Arrow to the next color and continue until a needle# is selected for all the color blocks in the design.

Currently-selected color block # / total color blocks

Left & right arrow keys select the color block number.

Use the up and down arrow keys to choose the needle number for the desired color.

How to Set the Color Block Sequence for A Design:

Follow steps 1-4 on the right to set the color sequence for a design. When finished, press ESC to return to the main menu, and/or ESC again to return to the main sewing screen.

Note: if a color block isn't assigned a needle #, that block will show a needle # of zero. When reaching that color block number during sewing, the machine will stop and prompt the operator to select a color.

Important Main Menu Screens: Pattern Screen

The control panel can store a maximum of 250,000 stitches of designs, or 99 designs total. The Pattern screen lets you choose from these designs if you wish to sew a design other than the current active design, as well as perform other design management functions such as deleting, re-naming, duplicating and locking designs.

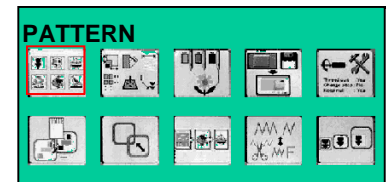

How to choose a design in the Pattern menu:

1. Use the blue arrow keys to select a pattern.
2. Press the SET key to make that pattern the active pattern.
3. Press ESC to return to the main menu.

Design Information – shows:

- Design name & number
- Stitch count
- # of color changes
- Height in mm
- Width in mm
- Distances from origin point to top & bottom edges
- Distances from origin point to left & right edges

This pattern is locked, preventing accidental deletion or modification.

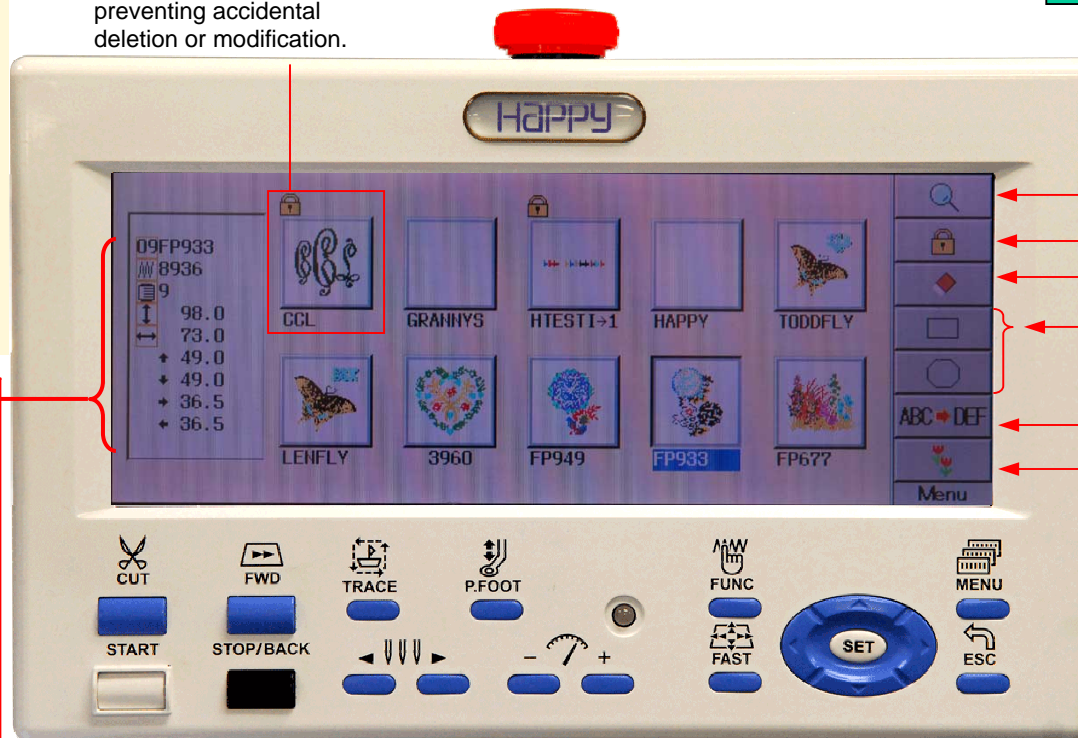

Additional Options (access these by pressing MENU)

- View pattern full-screen
- Lock selected pattern
- Delete 1 or more patterns
- Select trace types (slower outline trace or faster but less accurate area trace)
- Re-name selected pattern
- Duplicate selected pattern

NEXT: THE SETTING SCREEN

Important Main Menu Screens: Setting Screen

The Setting screen allows you to perform some useful modifications to the current pattern. Any changes made to a design in the Setting screen will be saved with that design and will be remembered as long as the design stays in the control panel memory.

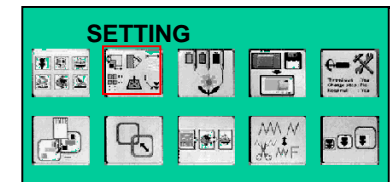

Left side of the Setting screen shows:

- Design information
- Outline of the design to display what's being done to the design i.e. rotation, new size, etc.

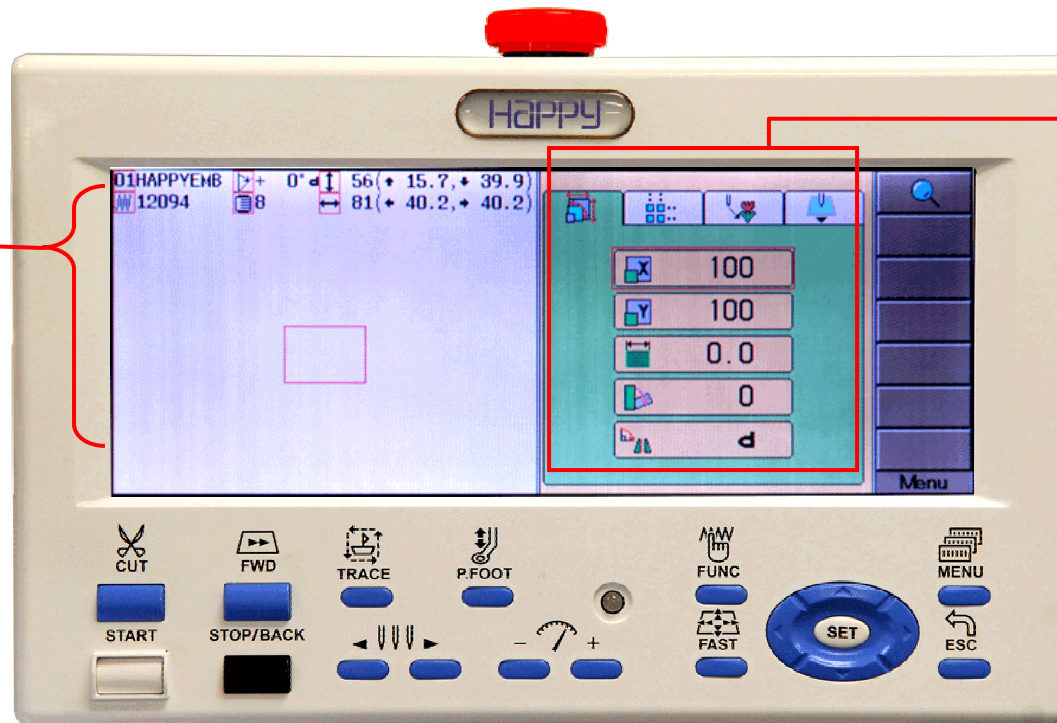

The **SETTING** screen is divided into 4 tabbed sub-screens. The functions on each tab are described on the next 4 pages.

NEXT: SETTING SCREEN 1st TAB

Important Main Menu Screens: Setting Screen

The Setting screen allows you to perform some useful modifications to the current pattern. Any changes made to a design in the Setting screen will be saved with that design and will be remembered as long as the design stays in the control panel memory.

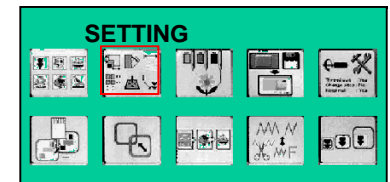

1st Tab: useful design editing functions

The functions found on the default first tab perform the most common edits: re-scale, satin pull compensation, and design rotation.

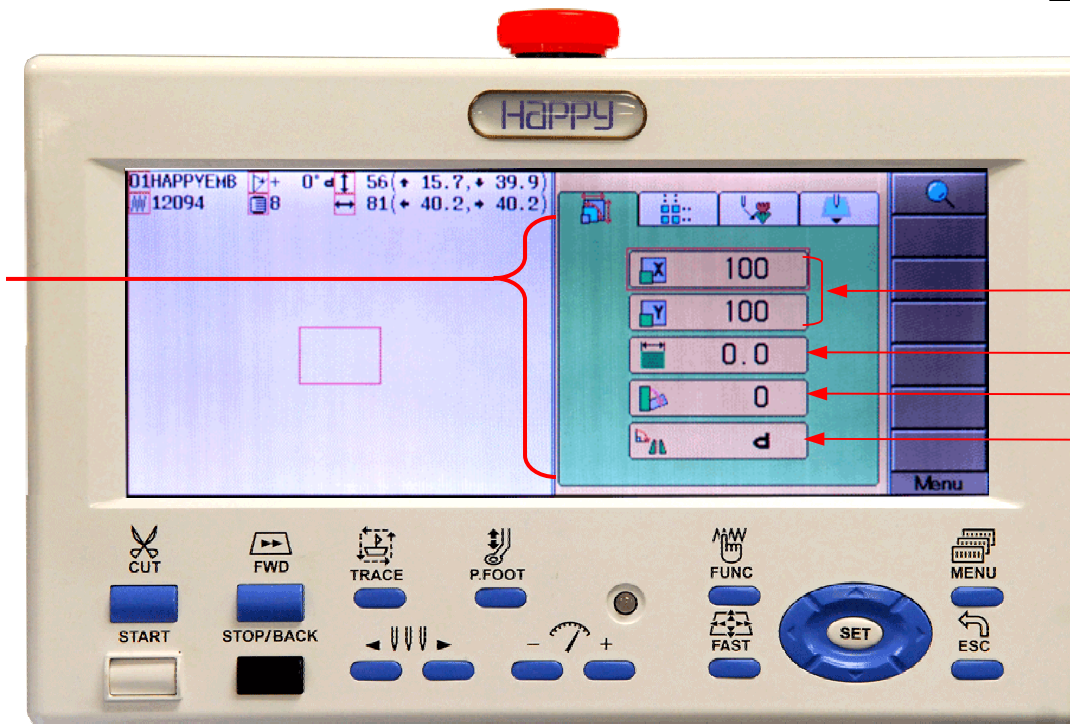

- Re-size design (no stitch processor)
- Satin pull compensation
- Rotate by degrees
- Rotate or flip (in 90 deg. increments)

NEXT: SETTING SCREEN 2nd TAB

Important Main Menu Screens: Setting Screen

The Setting screen allows you to perform some useful modifications to the current pattern. Any changes made to a design in the Setting screen will be saved with that design and will be remembered as long as the design stays in the control panel memory.

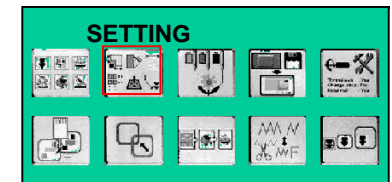

2nd Tab: Repeat

Function: This can be useful if you wish to sew the same design repeatedly on a large hoop i.e. to create a series of patches.

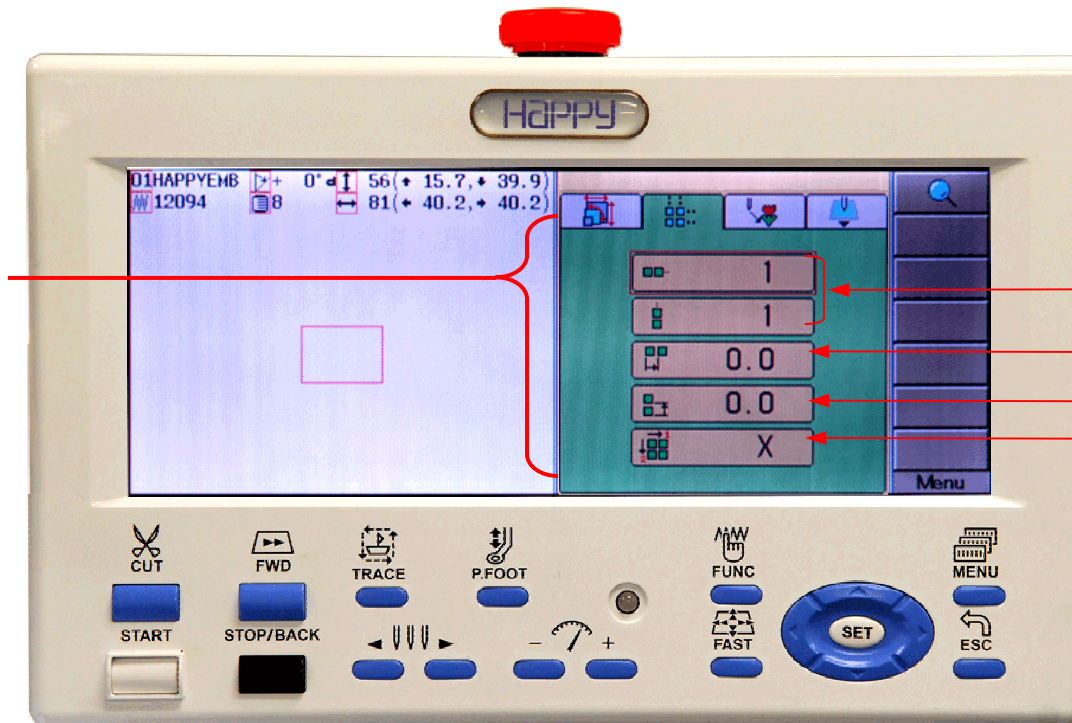

- Set number of rows and columns
- Spacing between columns
- Spacing between rows
- Toggle between "sew by row" or "sew by column"

NEXT: SETTING SCREEN 3rd TAB

Important Main Menu Screens: Setting Screen

The Setting screen allows you to perform some useful modifications to the current pattern. Any changes made to a design in the Setting screen will be saved with that design and will be remembered as long as the design stays in the control panel memory.

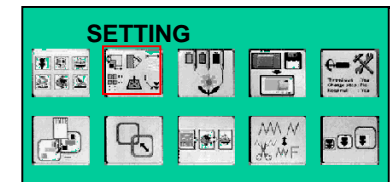

3rd Tab: Offset: This function allows you to program a design to sew a design offset from center by a given distance in mm in the X and Y directions. Note that -Y values move the design lower in the hoop and vice-versa. -X values move the design to the left in the hoop and vice-versa.

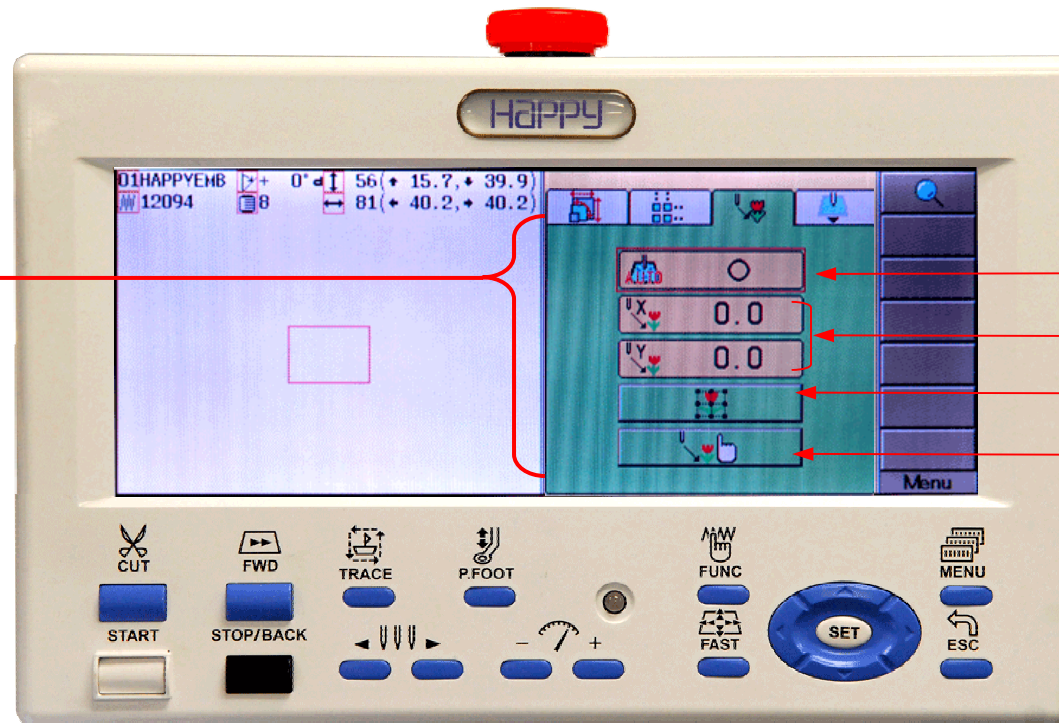

Toggle auto origin on or off

Set offset distance in mm for X and Y values

Set offset to a corner of the design

Set offset distance by using the arrow keys (sewing arm moves, letting you "eyeball" the offset)

NEXT: SETTING SCREEN 4th TAB

Important Main Menu Screens: Setting Screen

The Setting screen allows you to perform some useful modifications to the current pattern. Any changes made to a design in the Setting screen will be saved with that design and will be remembered as long as the design stays in the control panel memory.



4th Tab: Frame-out for applique

“Frame-Out” lets you command the machine to stop after sewing a specific color block number and then move the sewing arm towards you by a specific, pre-programmed distance. As an example, this is useful when sewing appliqué, where sewing needs to pause after the marker stitch has been laid. However, it can also be done more simply in the Needle screen (see page 12 in this chapter)

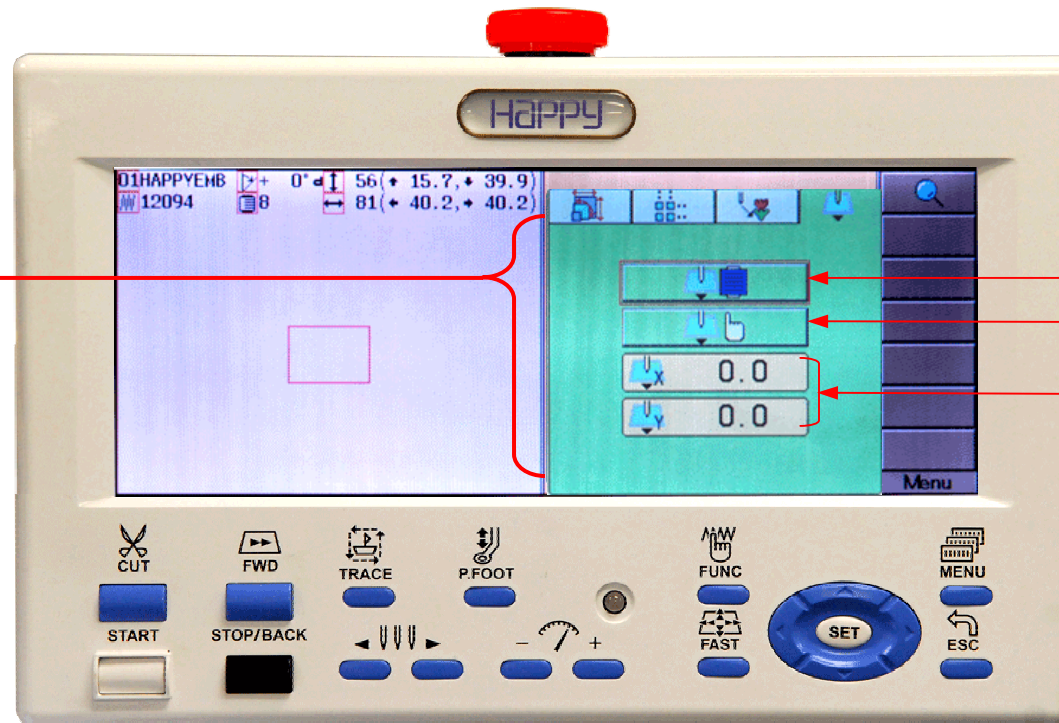

- Choose color block # where the frame-out occurs.
- Set frame-out by moving sewing arm
- Set frame-out movement numerically by entering exact X and Y values in mm

NEXT: THE READ SCREEN

Important Main Menu Screens: Read Screen

The Read screen is used to read designs from a compact flash card or USB jump drive.

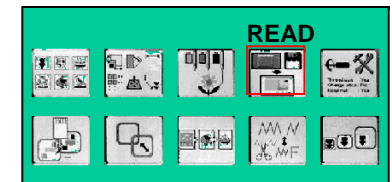

Choose **CF card or USB Jump drive** from the selections shown on the right when first selecting "READ".

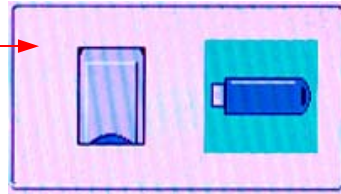

Right side: **design list from the card**: shows 8 designs at a time – to view the rest, arrow down below the list bottom or up to go higher.

Left side: **"read settings"** for the design: allows you to adjust the way the machine reads in a design. Some useful features are illustrated here.

combine jump – net effect reduces the number of trims in a design

stitch sweeper – always turn on. removes problematic short stitches.

sweep length –lets you set the max size of the stitches it deletes in tenths of a mm. 4 is the recommended value.

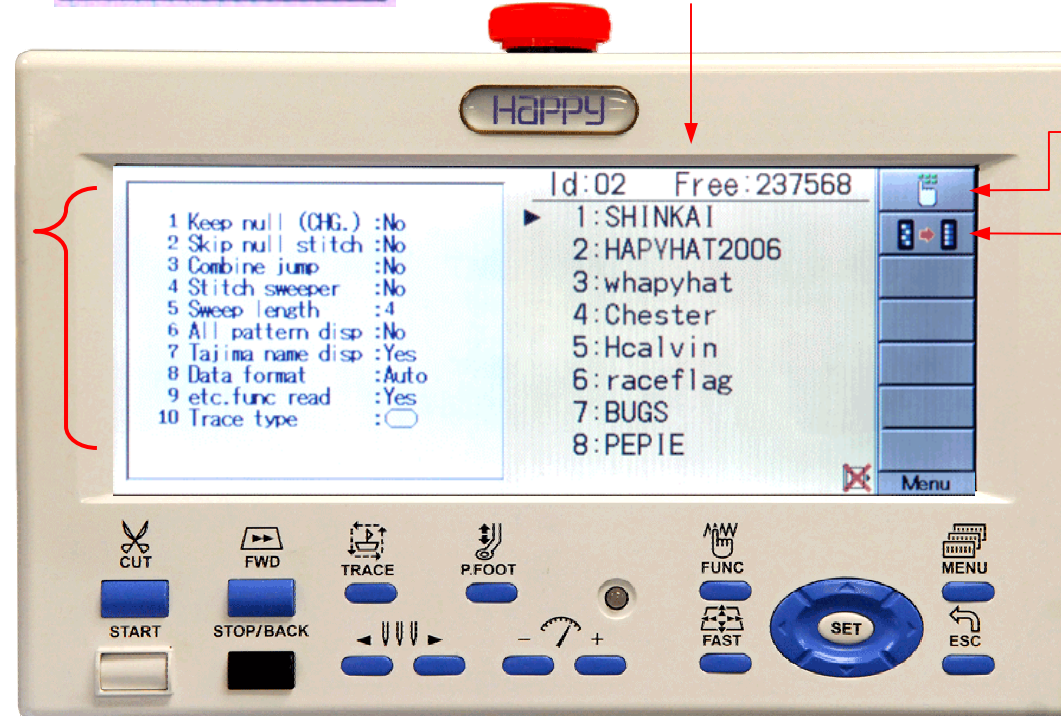

To access left side options

To set left side options back to factory defaults

NEXT: THE POSITION FUNCTION

Important Main Menu Screens: Position

Use the Position function if you wish to start sewing a design at any point other than the beginning. Note that this is not used to return to position after a power fail recovery or sewing interruption: in those cases, use the Position option accessed from the FUNC key (when in the main “drive” screen)

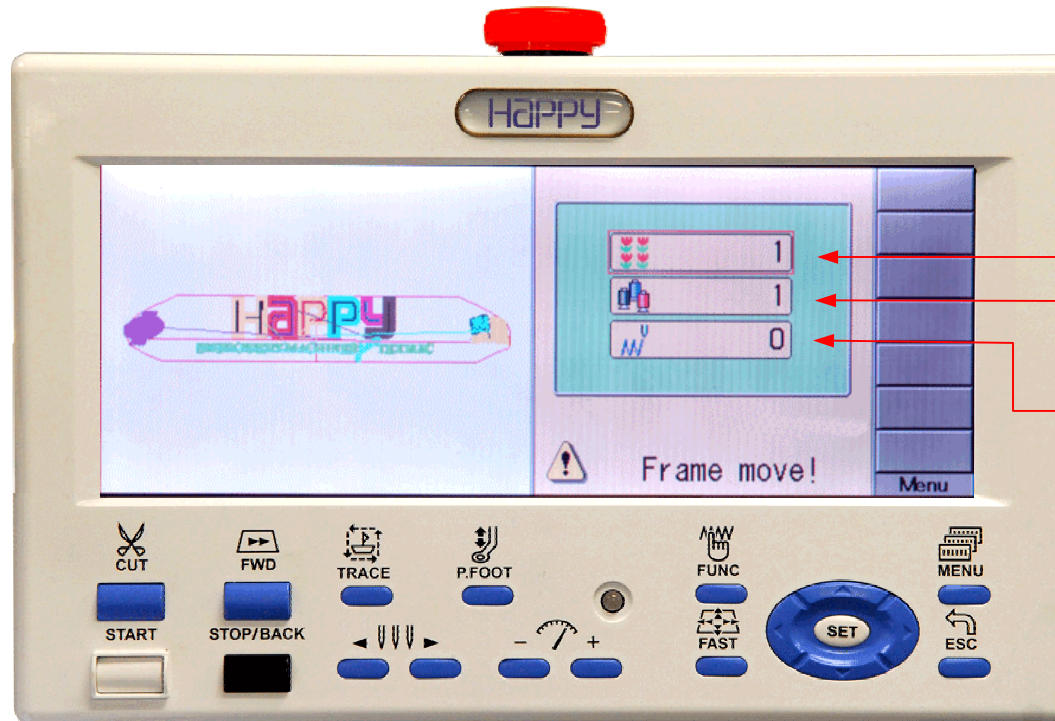

Set sewing position by repeat # (if repeat function is used)

Set sewing position by color block # - This is used most commonly.

Set sewing position by stitch# - Useful if you remember the exact stitch # where the machine left off sewing

NEXT: THE FRAME FUNCTION

Important Main Menu Screens: Frame Screen

The Frame function lets you choose a hoop for a design, check the design fit and adjust the design position within the hoop.

HOW TO USE THE "FRAME" FUNCTION

Follow the steps on this page and the next to use the Frame function.



1. Choose **Frame** from the main menu.
2. Choose **OK** and press **SET** to the prompt "Check the top of pattern data".

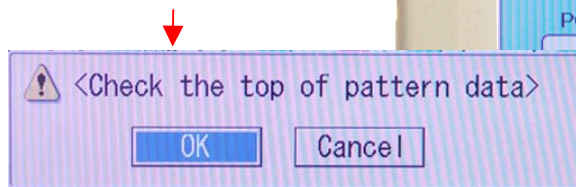

Continued on next page

Important Main Menu Screens: Frame Screen

The Frame function lets you visually check the fit of your design with a selected HAPPY hoop stored in memory.



HOW TO USE THE “FRAME” FUNCTION

Follow the steps on this page to use the Frame function. (continued from previous page)

3. Choose frame (hoop) type with left/right arrows – round, square, or user-defined.
4. The available hoops within that type appear in a list on the right. Arrow up/down to a hoop and press SET. Hoop sizes are indicated in mm in the right column (ignore the left column of 2-digit numbers). For example, if you wish to choose a 12cm hoop, choose “120”.
5. Press SET to select the hoop. Design outline appears in blue. Red line is the safety margin for the hoop. Black outline is outline of hoop itself.

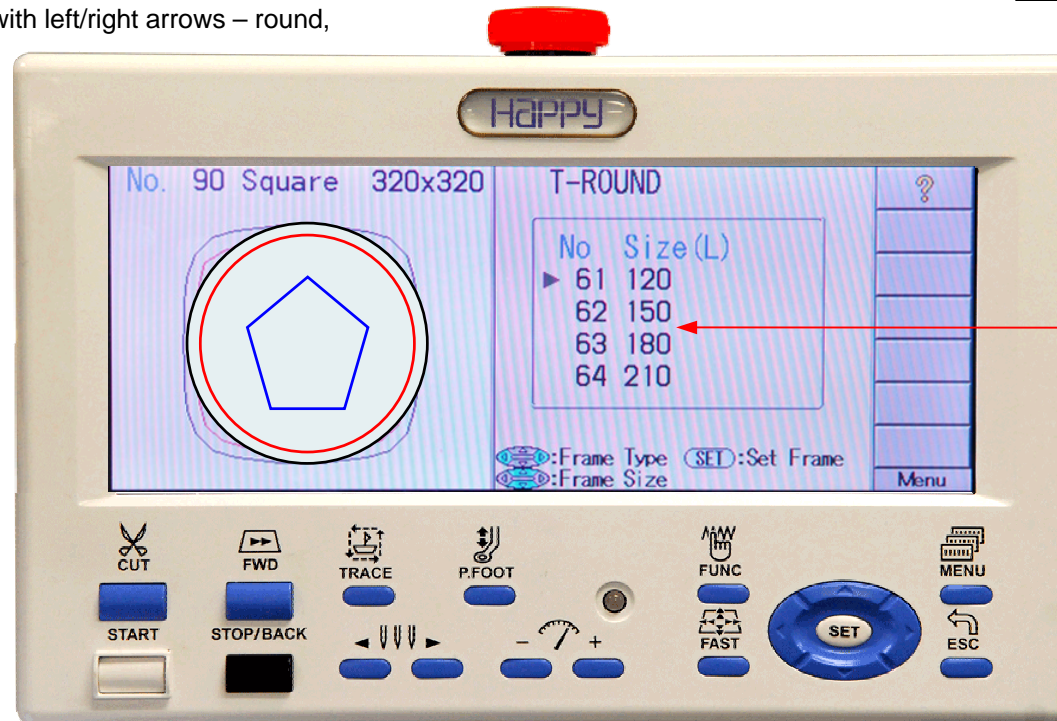

Choose a hoop and press SET: the right side numbers indicate hoop size in mm. (The left side number is an internal reference # and not useful)

6. Press SET once you've confirmed fit and position, which can be adjusted with the arrow keys.

NEXT: HOW TO SET UP FOR CUSTOM HOOP SIZES IN THE FRAME SCREEN

Important Main Menu Screens: Frame Screen

On this page and the next, you'll learn how to use the "user" option in the Frame function to choose a non-standard hoop instead of the library of HAPPY hoops.



STEPS FOR WORKING WITH CUSTOM SIZED HOOPS

1. Choose "USER" for frame type using the left/right arrow keys.
2. Select 1 of the 5 available slots and press SET to select a user-defined frame.
3. To edit/set up a selected user-defined frame, press MENU after selecting it. This allows you to choose the Data Entry mode for that hoop. (shown top right).

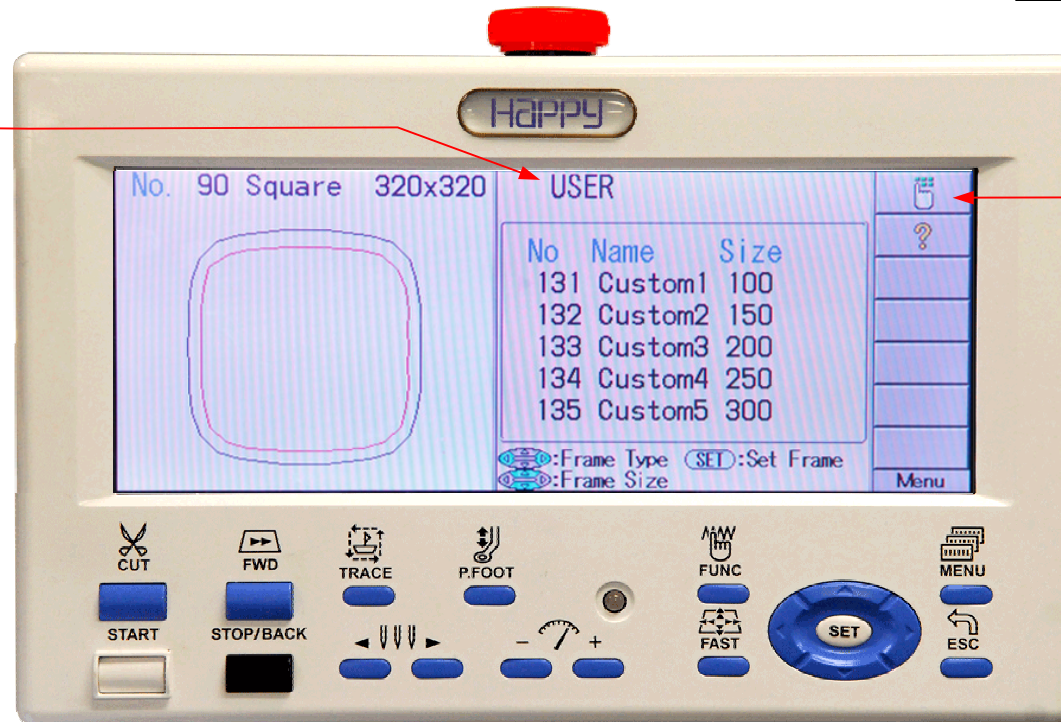

Option to set up selected user defined hoop

Continued on next page

Important Main Menu Screens: Frame Screen

On this page and the next, you'll learn how to use the "user" option in the Frame function to choose a non-standard hoop instead of the library of HAPPY hoops.



STEPS FOR WORKING WITH CUSTOM SIZED HOOPS

4. **Set the hoop class** – choose round or rectangular then press SET.
5. **Set the hoop size** – For a round hoop, you'll be able to enter a single number – its useful diameter in mm. For a rectangular hoop, you'll be able to enter both length and width in mm.
6. **The new hoop size will appear** next to the custom slot you've set up.

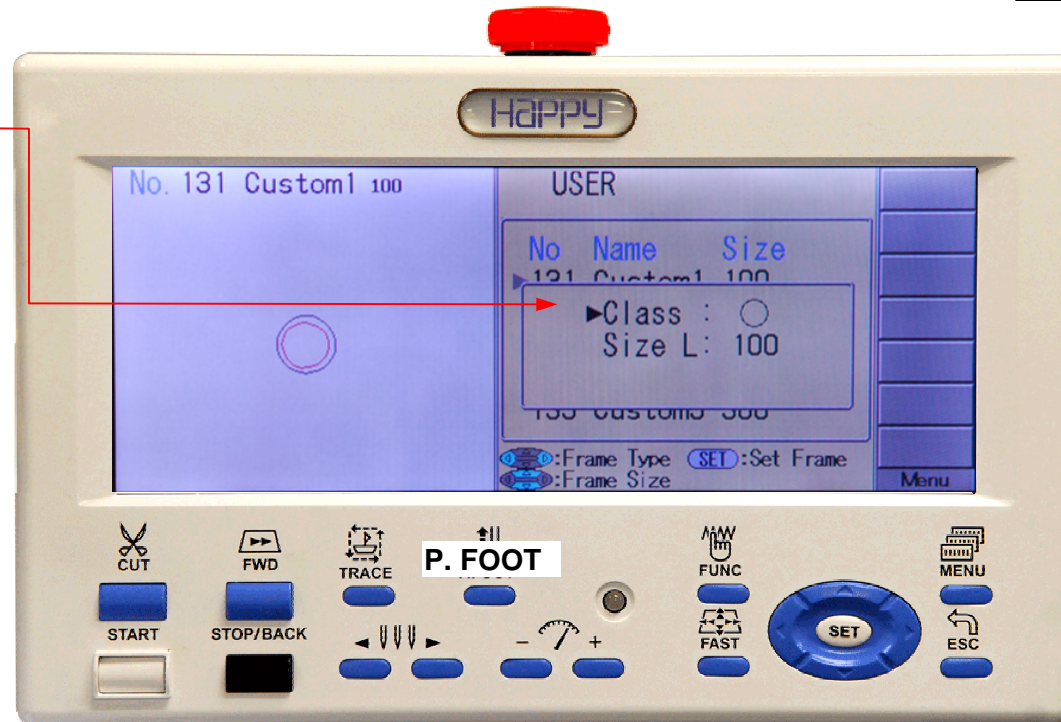

NOTE: On 3rd-party hoops, actual sewing area may differ from hoop's stated size, based on hoop shape presser foot clearance and other factors. Always test sewing area after entering hoop dimensions. This is especially true of square/rectangular hoops.

Next: Transferring Designs

Transferring Designs into Your Machine

In this section, we provide detailed steps about the 2 most common ways to transfer a design into your machine to be sewn:

- **USB connection** or
- **Flash media (CF card or USB Jump drive)**

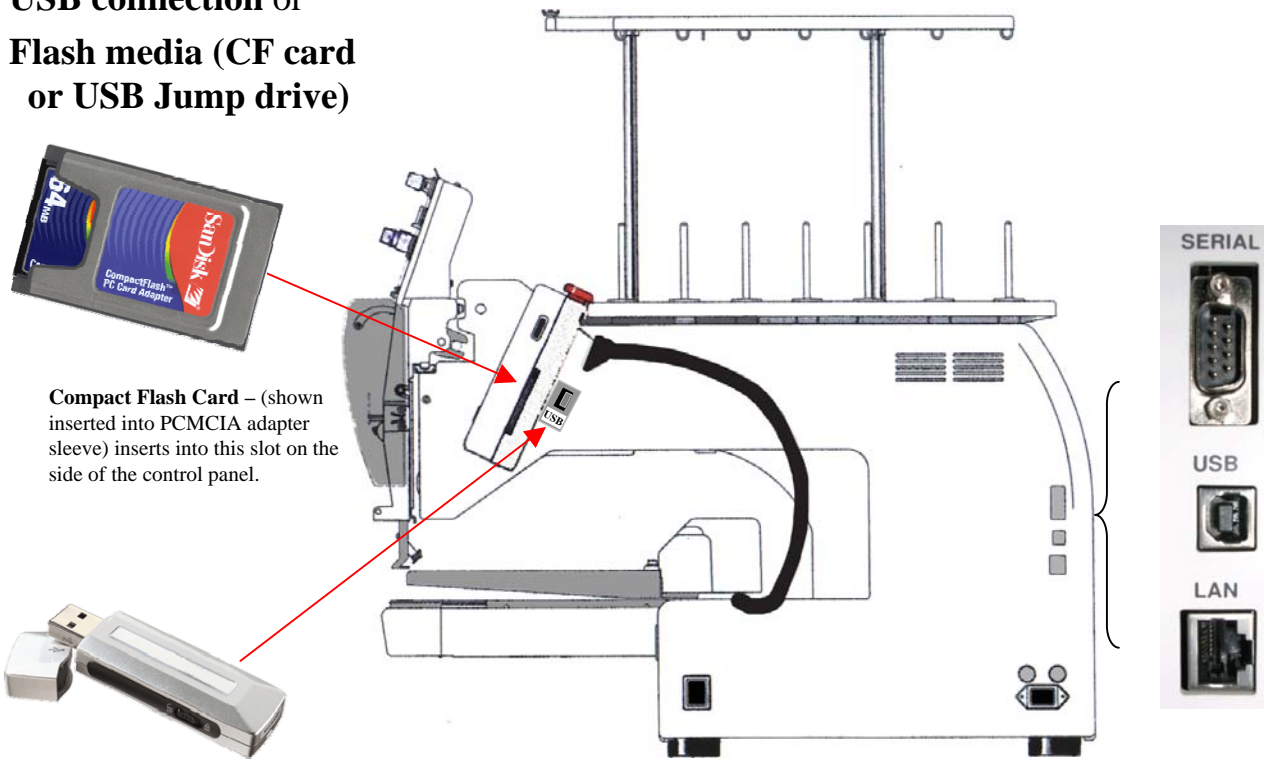

Compact Flash Card – (shown inserted into PCMCIA adapter sleeve) inserts into this slot on the side of the control panel.

USB “Jump” drive – connects in to this port just behind the control panel on later-model 2008 Voyagers. Accepts up to 1Gb max USB jump drives.

USB port is found on side wall of machine with other ports. You can connect a Windows PC to the machine with a USB cable so you can transfer designs and perform other functions.

On the following pages, we’ll go over the steps for both methods in detail. Next: USB connection

Transfer via USB Connection

One-Time Set-up of the USB Connection (continued from last page)

Follow the steps on these pages to set up your PC for a USB connection. You'll only need to do this once.

1. Run the CD that came with your machine before connecting your HAPPY machine to your computer.



2. Wait for the CD install screen to appear.

3. Install HAPPYLINK. Install 3.07 or newer for Vista 64 or Windows 7.

4. Click to install the appropriate USB driver for your Windows Operating system.



5. Launch the HAPPYLINK program you installed in Step 3.

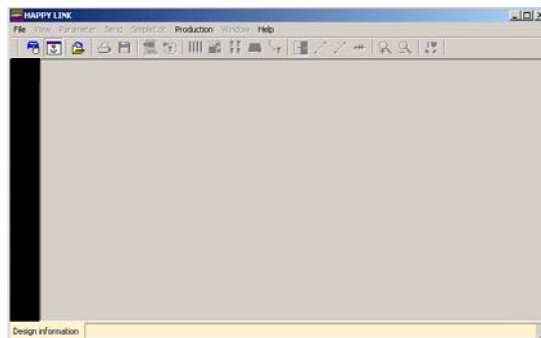

HAPPYLINK program window

6. Click on File...Options until the dialog box shown below appears. Ensure that the dialog box is set as shown below, then click OK.

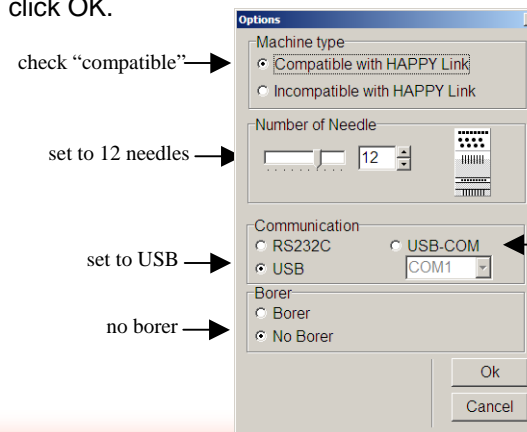

For 64-bit versions of Windows Vista and all versions of Windows 7, choose USB-COM. You'll have to find the port# after connecting your Happy machine via USB cable and letting the driver set up, as in the next page. Return to this screen here on the left after finding the virtual COM port# assigned to your HAPPY machine by Windows.

Transfer via USB Connection

One-Time Set-up of the USB Connection (continued from last page)

Follow the steps on these pages to set up your PC for a USB connection.

5. Ensure that your HAPPY machine is turned off, and connect a USB cable between your PC and the machine. You may use the cable that came with your machine or purchase a longer one at any computer supply store. Ensure that any USB cable you purchase is high-quality and under 16 feet.

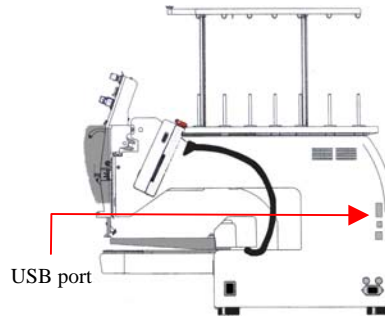

Connect USB cable to any USB port on your PC.

6. Power on your HAPPY machine and watch your PC screen. Windows should detect the machine, starting the Hardware Installation Wizard, similar to what is shown below.

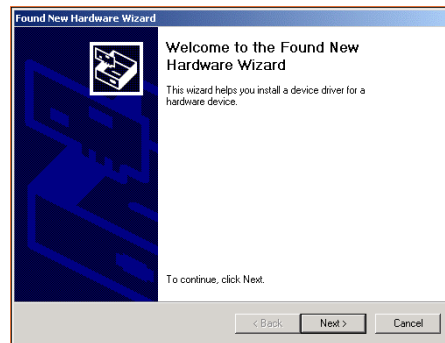

7. Continue through the prompts, ensuring that at some point, Windows identifies the new hardware as "02 Happy Embroidery Machine" for Windows XP / Vista 32, or, in Vista 64/Windows 7, lists it in the Device Manager under Ports. Be sure to note the port#.

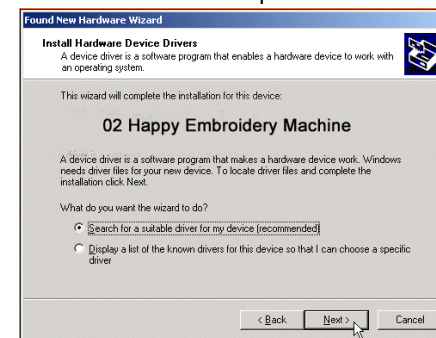

8. Continue until the message "Your new hardware is installed and ready to use" or a similar message appears.

Transfer via USB Connection

One-Time Set-up of the USB Connection (continued from last page)

Follow the 11 steps on these pages and the next to set up your PC for a USB connection.

11. **Launch the HAPPYLINK program** again. If you've done everything correctly, the USB connection indicator should appear as a solid grey icon in the top-left corner of the program bar as shown below.

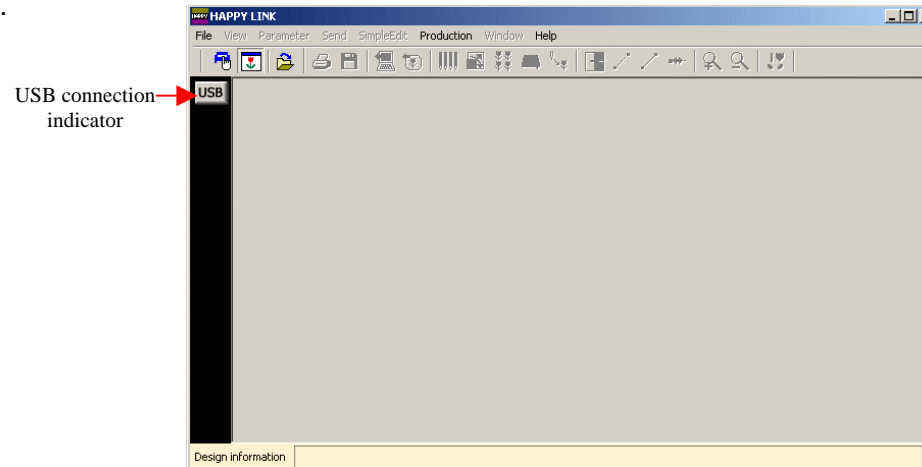

NEXT: Actual Steps to Transfer a Design by USB Cable

Transfer via USB Connection

Actual Steps to Transfer a Design by USB

Once you've properly set up HAPPYLINK and the USB drivers on your PC, you'll only need to follow the 5 steps on this page to actually transfer designs.

1. Ensure that the machine is powered on and at the main (drive) screen. Your PC will only be able to transfer designs from this screen.

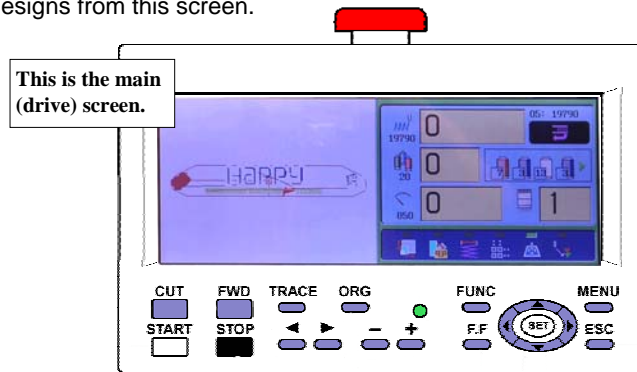

2. Connect the USB cable between machine and PC if you haven't already done so.

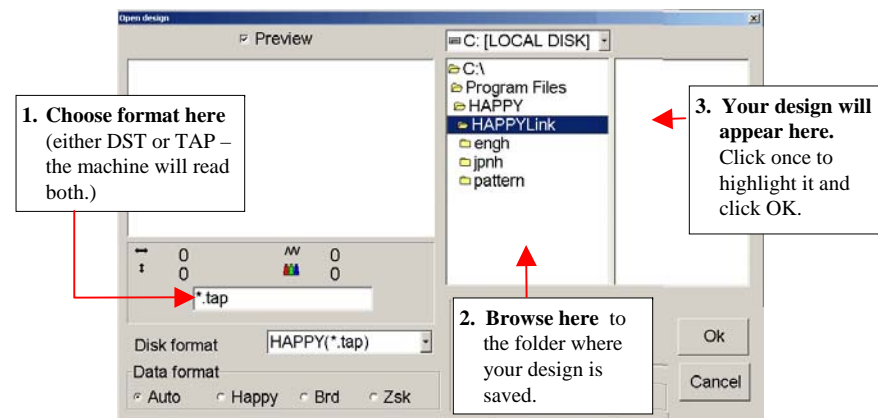

3. Launch the HAPPYLINK program and check to ensure the USB icon is lit. 

4. Open your design by clicking on File...Pattern Open. The above dialog box appears. Follow the directions indicated above, and your design should open (in grey tones) into HAPPYLINK.

5. Click the Send Pattern Icon. The design will transfer from your PC to the machine.

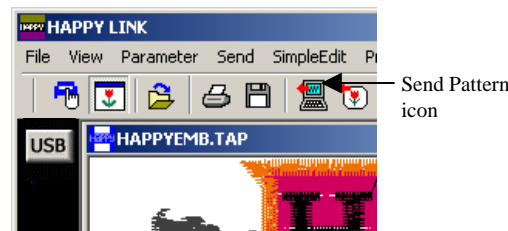

Transfer by CF card or Jump Drive

Which Compact Flash cards to buy

The slot located on the side of the machine's control panel accepts flash memory cards, to allow you to transfer designs into memory from a computer. To do this, you'll need to buy the 3 items shown on this page from most stores that sell computer or digital camera supplies.

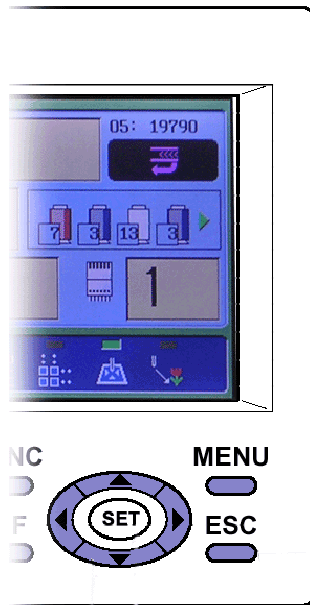

-
1. **PCMCIA Adapter** – Allows the card to fit into the machine's flash card slot. For PC's (some laptops) that also accept PCMCIA cards, there is no need for (3) the USB to compact flash adapter.
 2. **Compact Flash card** – This is the memory card itself. Your machine accepts compact flash cards up to 1 Gigabyte in size. **NECESSARY.**

3. **USB to compact flash card reader** – needed if your PC does not have a PCMCIA slot. (most don't, though some laptops have one). Allows you to connect your card to a computer and save designs to it.

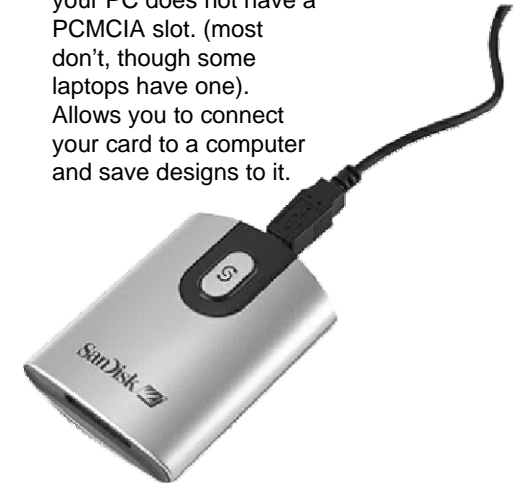

USB "Jump" Drives are a little easier to work with they require no adapter and plug directly into the USB port behind the control panel. They are not as brand-specific. Larger capacity jump drives are more likely to work. Be sure the drive is formatted in FAT32 for capacities larger than 1Gb.



NEXT: ALTERNATE FORMS OF FLASH MEDIA

Transfer by CF card or Jump Drive

Other Types of Flash memory (What not to Buy)

Your HAPPY machine was designed to accept other types of Flash cards, but none have worked as successfully as Sandisk-brand compact flash cards. For your assistance, we've identified other types of flash memory cards available below. We have attempted to show the cards approximately to scale with each other. Note that compatibility with these types may improve as revisions of the machine's on-board firmware and hardware are released.

GOOD



SanDisk brand Compact Flash card: This has worked with the greatest success with HAPPY machines, and is widely available.



Jump Drive Brands: To date, most brands of USB jump drives have worked. Most larger capacity drives are even readable (4Gb, 8Gb, etc)



Other brands of compact Flash card: Some other types work, although not all.



Memory Stick: This has been the least successful of the other Flash media types



SD Card: Few brands of this type have been found to work.



Other Types of Adapter Sleeves: All-in-1 adapter sleeves have had limited success, even Sandisk brand.



SmartMedia Card: Few brands of this type have been found to work.

NEXT: HOW TO USE YOUR COMPACT FLASH CARD or JUMP DRIVE

Transfer by Flash card or Jump Drive

How to Use CF Cards or USB Jump Drives to Transfer Designs

Follow the steps on these pages to transfer designs from a PC into your HAPPY machine with a Compact Flash card.

- 1. Connect the Compact Flash card or USB Jump drive to your computer.** For compact Flash, insert the card into a PCMCIA adapter first (if your laptop has this type of slot) or otherwise insert it into the USB reader.

- 2. Start HAPPYLINK and open the design** you wish to transfer from File... Pattern Open. You'll see the dialog box below appear. Follow the directions.

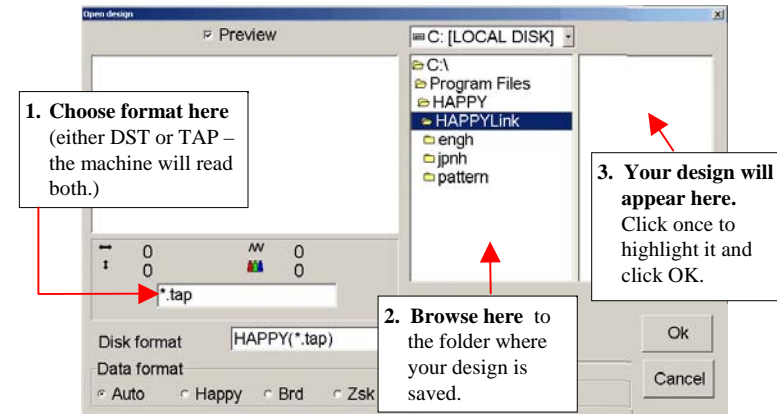
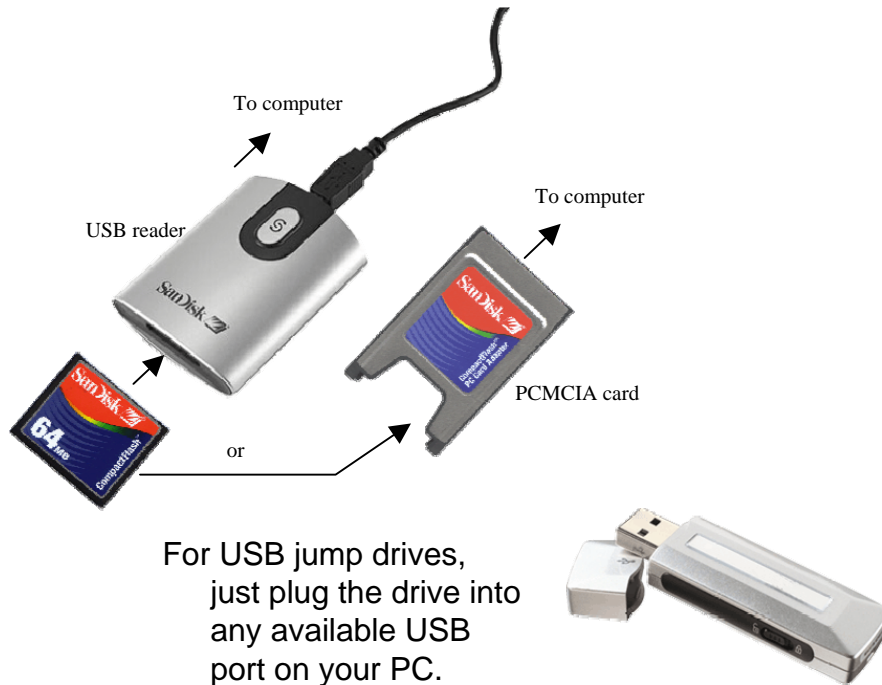

Transfer by CF card or Jump Drive

How to Use CF Cards or USB Jump Drives to Transfer Designs

Follow the 9 steps on these pages to transfer designs from a PC into your HAPPY machine with a Compact Flash card.

- (optional step) Set the color sequence.** Click on the icon shown below to do so. Or if you choose, you can set colors in your machine.

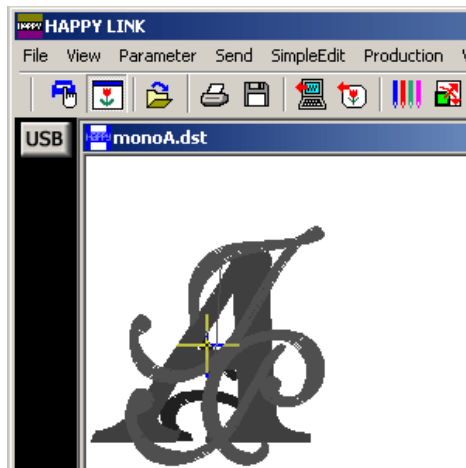

- Save the file to the Flash card or Jump Drive.** Click on File...Save As. The dialog box shown below appears. Look for "removable disk" in "Save in" give it a name and click Save. **Then, close HAPPYLINK.**

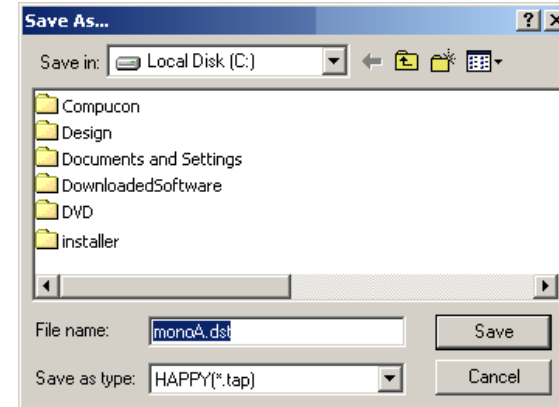

- Click on Safely Remove Hardware Icon** to shut off the card. You'll find this icon at the lower-right edge of the screen near the clock. Continue until the message "It is now safe to remove" appears.



Transfer by CF card or USB Jump Drive

How to Use CF Cards or USB Jump Drives to Transfer Designs

Follow the 9 steps on these pages to transfer designs from a PC into your HAPPY machine with a CF card or USB jump drive.

6. **Insert the Flash card or USB jump drive into the machine.** For a CF card, you'll need to insert the card into the PCMCIA adapter sleeve.

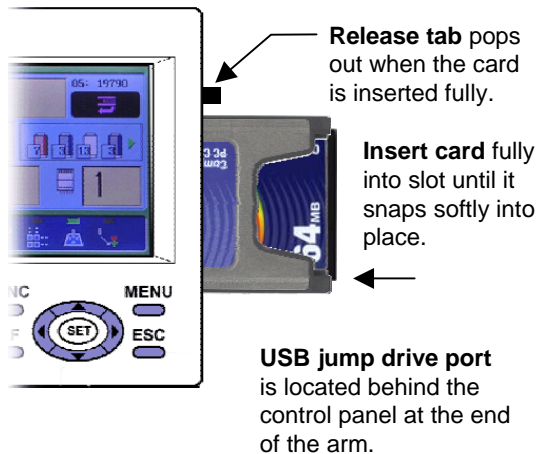

7. **Go to the Read screen** in the control panel to read the card. From the main (drive) screen press MENU and click the blue arrow keys to go to the READ and press SET. In the window that appears, choose Flash card or jump drive and press SET.

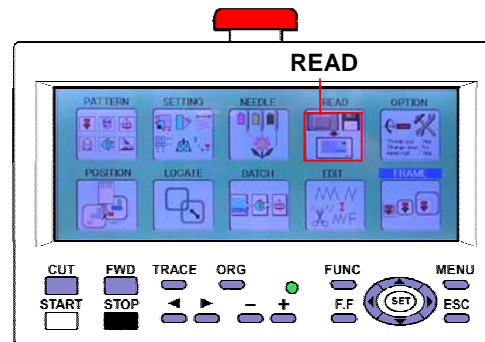

8. **Find your design in the list.** Any DST & TAP designs will show automatically in a list on the right. Choose your design with the blue arrow keys and press SET.

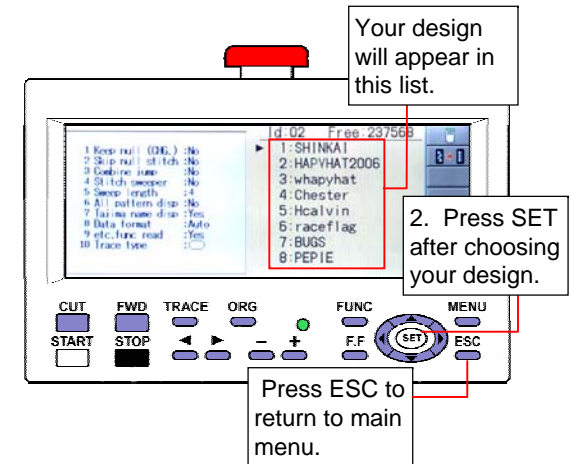

9. **Press ESC to return to the main (drive) screen.** Once the design is imported from the READ screen, press the ESC button until you've returned to the main Drive screen, where image of your design should now appear. (The next step will be to set the colors in the Needle screen.)

NEXT: CHAPTER 3: COMPLETE STEPS IN A TYPICAL SEWING JOB