



Training:

HAPPY HCS-1201 Voyager Operations & Maintenance **For Voyager, Color Monitor with Firmware v1.14**

Chapter 1: Introduction & Embroidery Theory

- **Overview of your machine** *p.2*
 - Diagram of major parts
- **Overview of major mechanical systems** *p.3*
 - Color change system, sewing system, X-Y pantograph
- **Control Panel Introduction & Orientation** *p.4*
 - Adjustment / emergency stop
 - Power-on & navigating to the main sewing screen
 - Shutting down
- **Other Important Screens: A brief introduction** *p.8*
 - Function menu
 - Main menu, pages 1 and 2
- **Embroidery basics & theory** *p.12*
 - About stitches, sewing quality, stitch file formats, the embroidery needle

Overview: A Quick Tour of the Machine

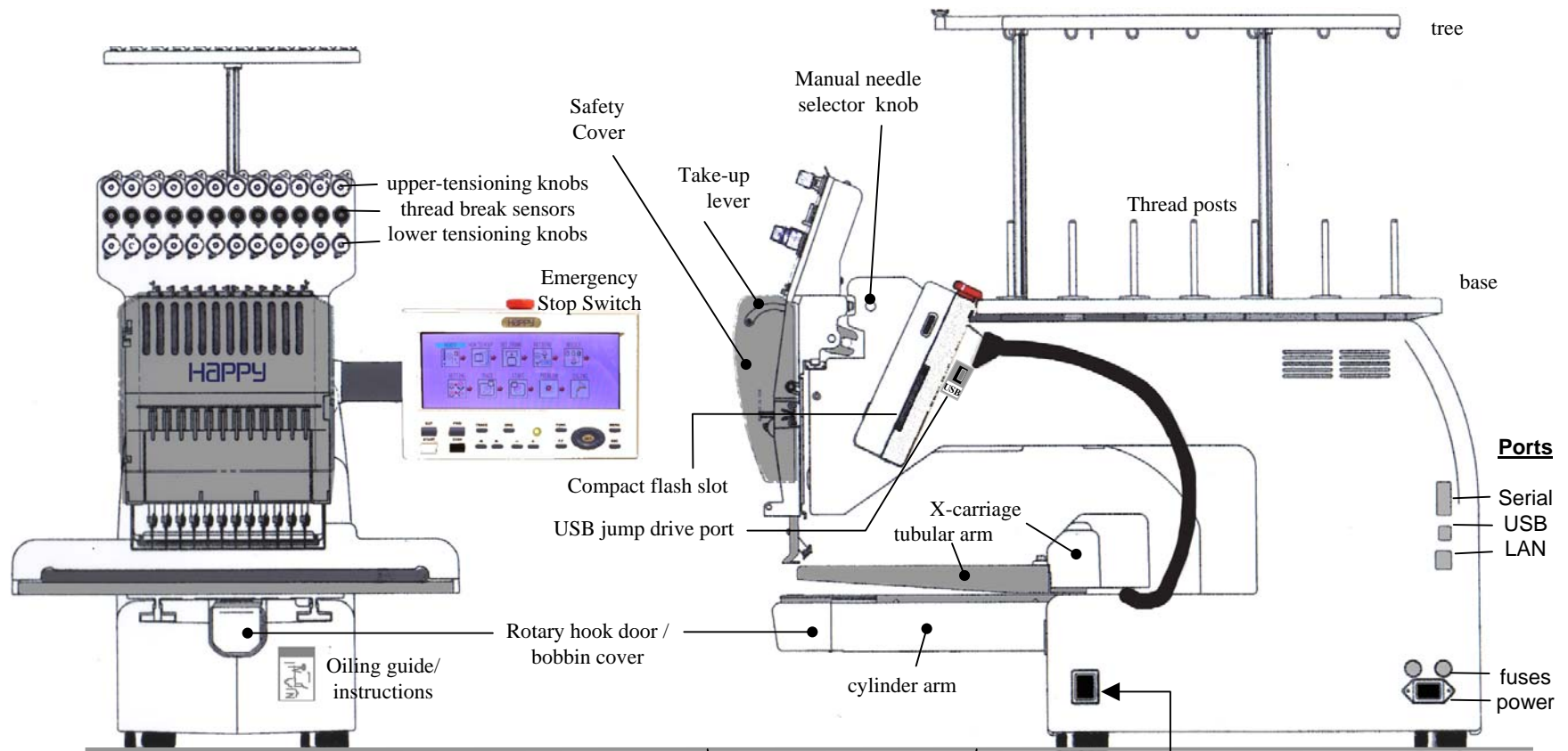

Table area beneath cylinder arm:: for tubular goods, table or other object under cylinder arm can provide support. For garment, however, cap driver requires that surface be at least 4" below level of feet.

Main power switch: Press and hold continuously for 1-2 sec. to power on

Overview: 3 key mechanical systems

1. Color Change System

Moving head
Thread cut system

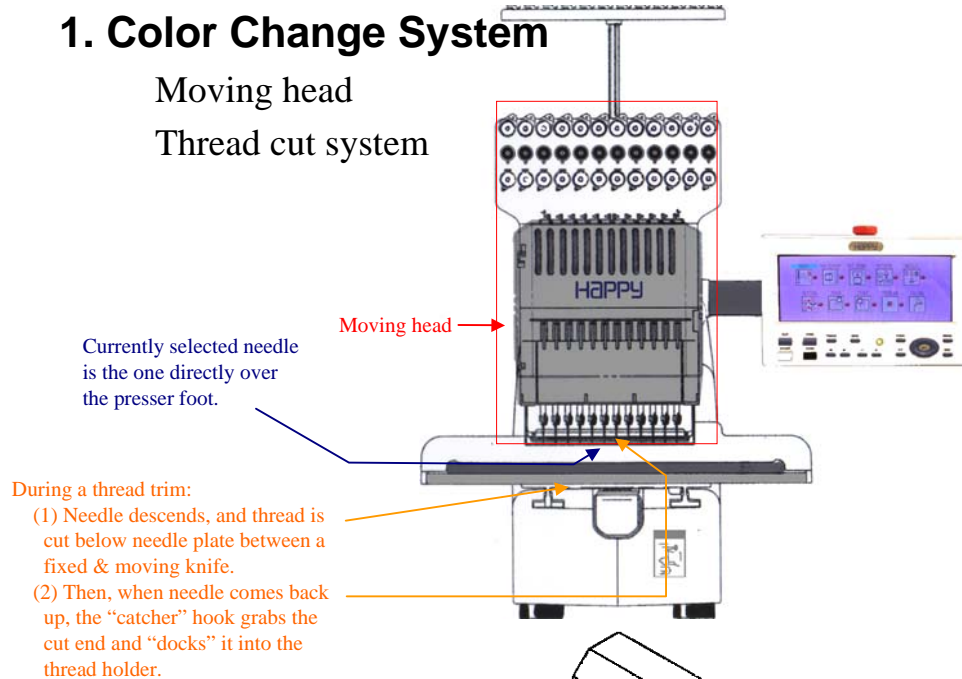

3. X-Y Pantograph

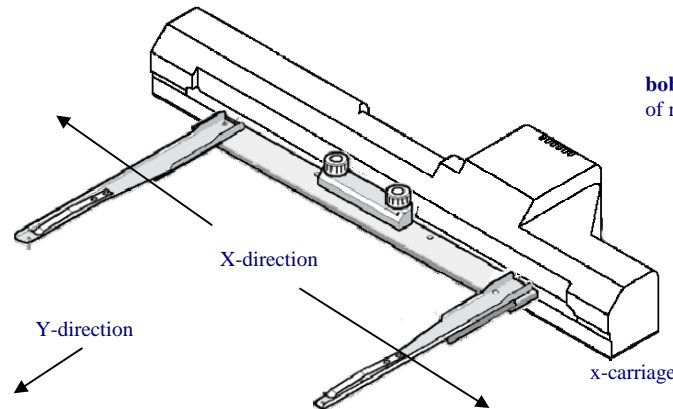

2. Sewing System

Take-Up Lever
Needle bar
Rotary hook / bobbin

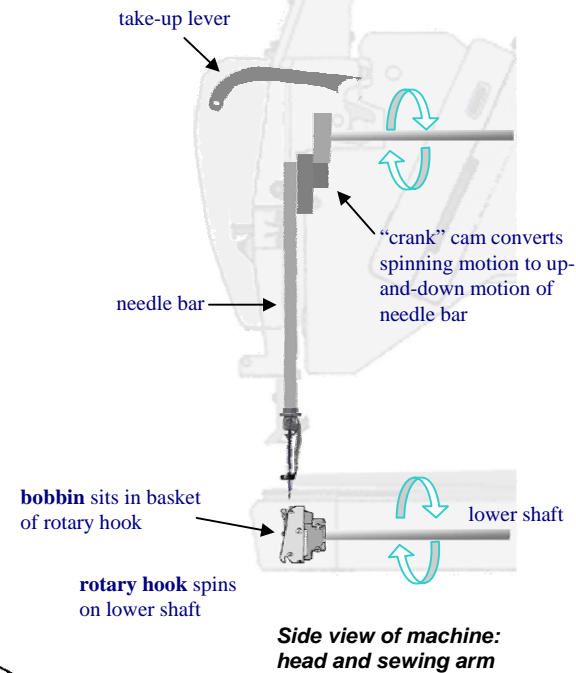

Control Panel Intro: Quick Orientation

Emergency Stop

This button is used to shut the machine off in case of emergency. The machine will remember the last sewn stitch but may be slightly off alignment when re-started. To recover from emergency stop, clear any problem, un-twist the button to re-set it and power on normally. The machine will not power on unless the button is re-set to the “on” position.

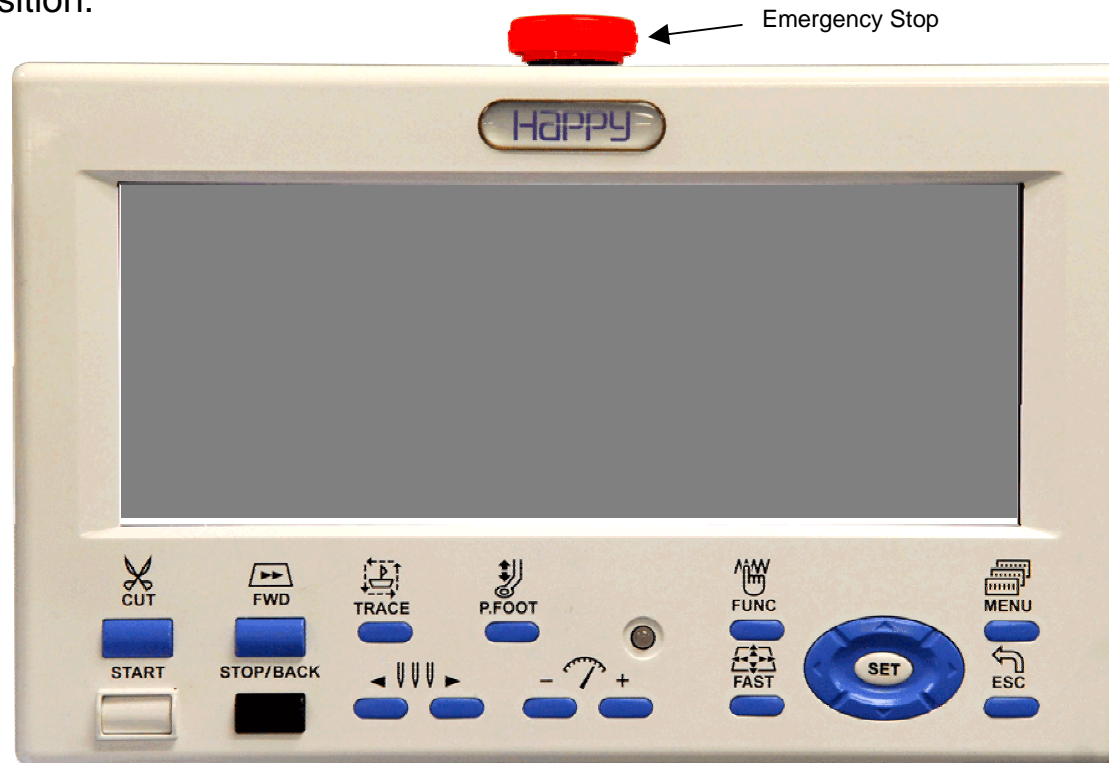

Control Panel Intro: Power On to the Main (Drive) Screen

Initial Power-On

Power on your machine with the black switch located on the side of the machine. The screen below appears.

This startup screen appears at power-on.



Reminder tells you to press "SET".

Next: How to enable/disable on-board help on startup

Control Panel Intro: Power On to the Main (Drive) Screen

Getting to the Main Screen

The Guide or on-board help function appears by default when pressing SET to continue. You can disable this feature as shown below to go instead directly to the main “drive” screen.

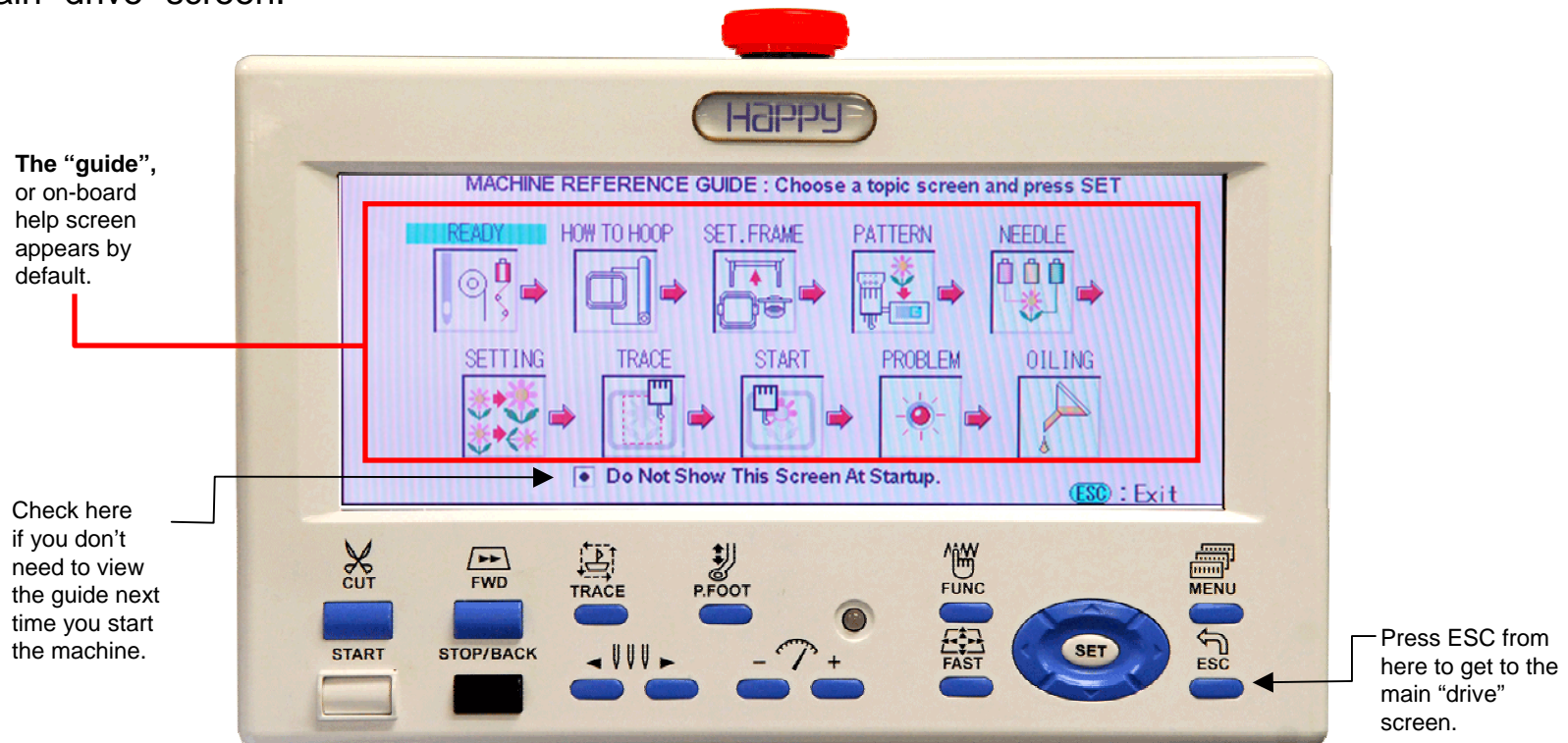

Next: The main (drive) screen

Control Panel Intro: Power On to the Main (Drive) Screen

Getting to the Main Screen

This is the main “drive” screen. The machine will not sew or accept design transfers via cable unless it is in this mode. Learn how to get to this screen either from power-on or by pressing ESC.

This is the main “drive” screen.



Origin Symbol: shows that the current design is at the origin and ready to begin.

Active needle: current needle

Control Panel Intro: Other Important Screens

The FUNC menu and shut-down

In addition to the main Drive screen, there are 2 other important menus to know: The Main Menu (shown on the next page) and the Function menu, shown below, which is accessed by pressing FUNC.

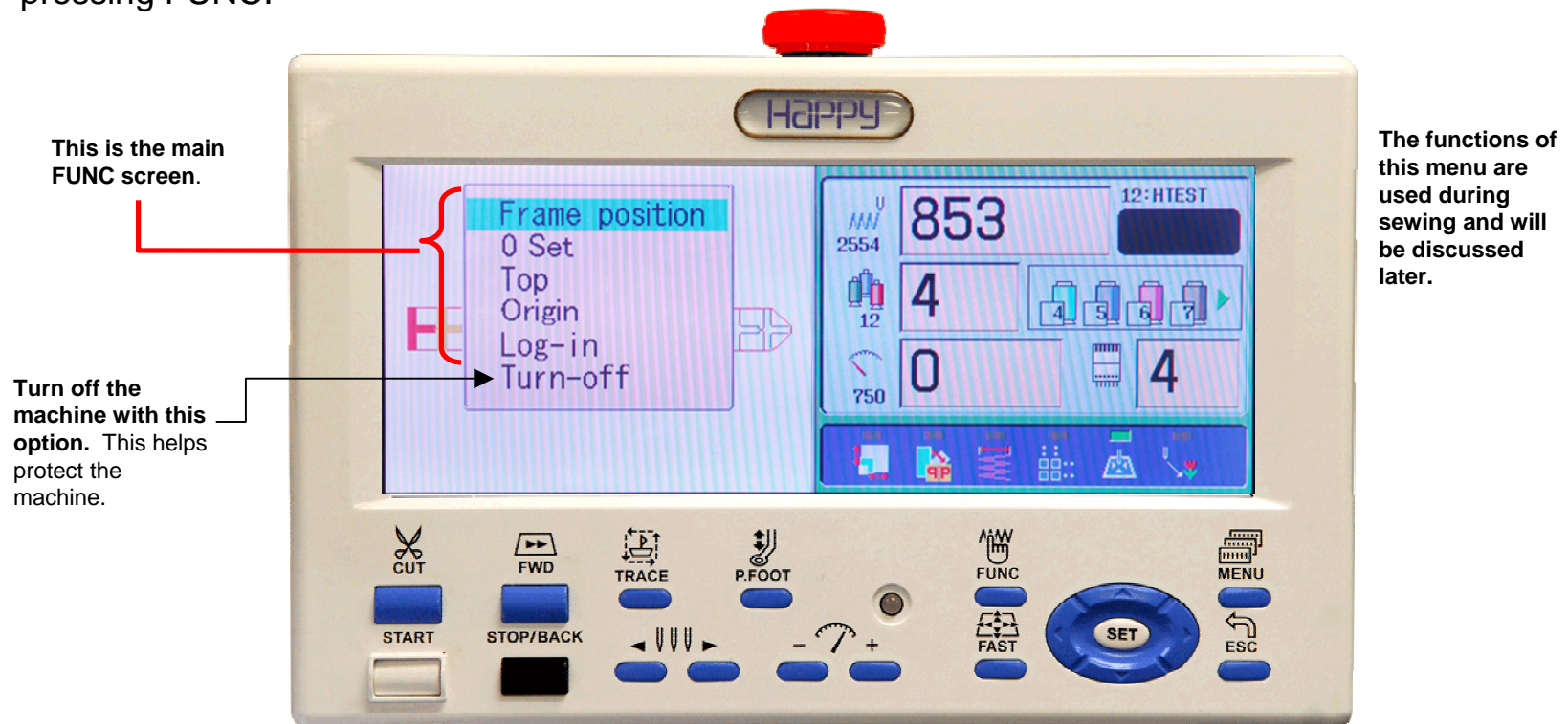

Control Panel Intro: Other Important Screens

The Main Menu

The other - and most important - menu is the Main Menu, accessed from the main Drive screen by pressing MENU as shown below.



Press the MENU button to get to the main menu.

Control Panel Intro: Other Important Screens

The Main Menu

This is page 1 of the main menu. In the next chapters we'll show the functions in-depth for 6 of its functions, which you'll use regularly as you sew with your machine.

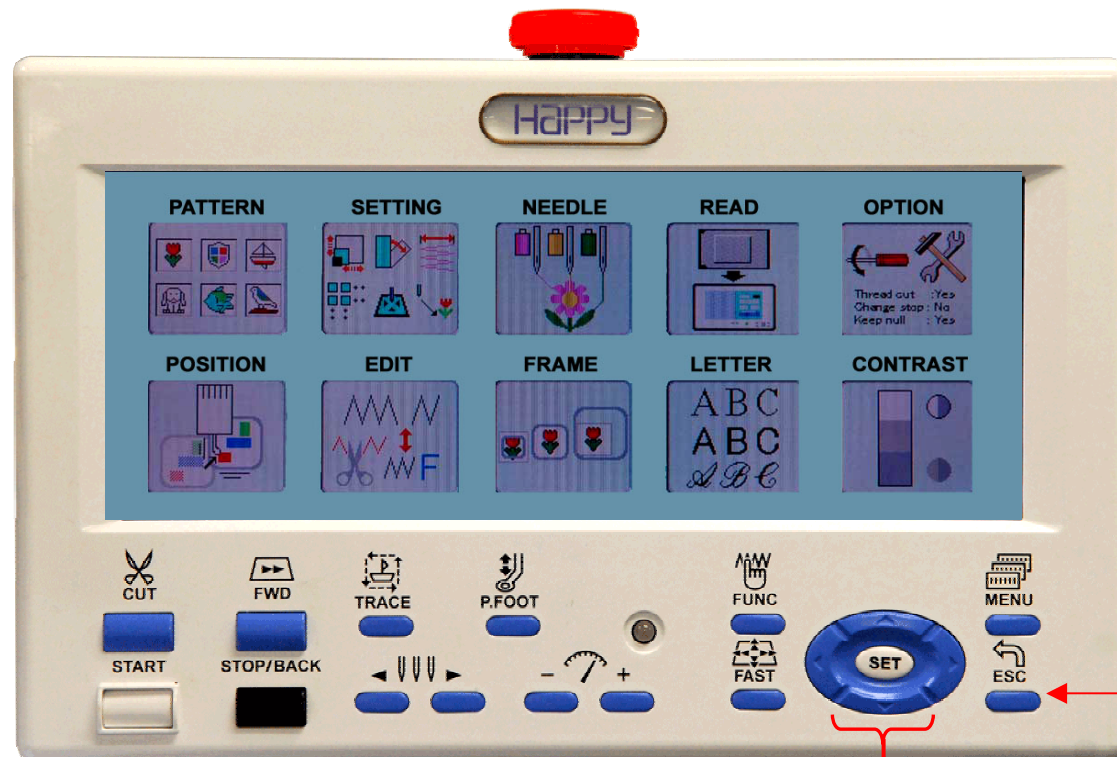

Navigate to a menu item using these 4 blue arrow keys, then press SET to enter the screen for that item.

Press the ESC key exits you to the main (drive) screen.

Control Panel Intro: Other Important Screens

The Main Menu

This is page 2 of the main menu.

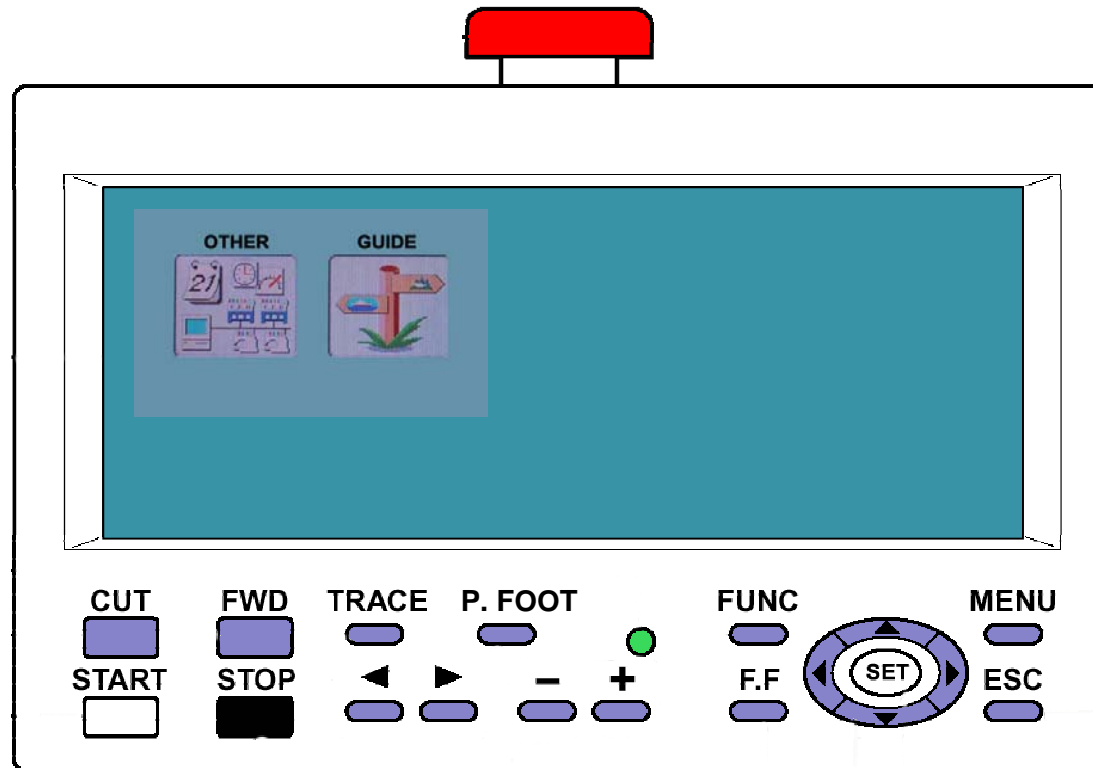



Key Embroidery Basics / Theory

- **About Stitches :**
 - **All stitches are formed** by a ½ loop of colored thread looped with ½ loop of bobbin thread.
 - **Max and minimum length:** Must be between 1mm (.04 inch) and 12.7mm (1/2 inch). Too short causes thread breaks. Too long, stitches are too loose.
- **3 Major Factors Affecting Sewing Quality that you can control:**
 - **Tension** – once properly set, should rarely require re-adjustment. We will cover this in class.
 - **Hooping** – proper hooping is a must. Not too tight, not too loose. We will cover this in class.
 - **Digitizing** – hire a digitizing service and/or learn how to digitize in digitizing classes.
- **Sewing file format used in embroidery: DST**
 - All commercial machines read this format
 - Does not have color information – must load the design into the machine AND tell it which colors to sew.
 - Limited in editability – the design must be sewn at the size it was digitized.
- **About Embroidery Thread**
 - **Upper (colored) thread**
 - Can be polyester or rayon, usually polyester. Standard is 40 weight
 - Comes in several sizes: 5,000 meter cones to 1,000 meter cones.
 - Handle carefully: physical contact, oil/dirt, moisture can prevent it from unspooling smoothly and catch
 - **Bobbin thread**
 - L-type, approximately 350 yards per spool. Bobbin thread will have to be changed more frequently than upper thread
 - Lasts approximately 25,000 to 60,000 stitches, depending on fabric thickness, thread tension and other factors.

Key Embroidery Basics (continued)

- **Embroidery Needles:**

- **Type DB-K5, standard size is 75/11 ballpoint for most applications.** Alternate needle for sewing caps and other tightly-woven goods (heavy canvas) is 80/12 sharp point for better penetration and a wider shaft to resist breakage, especially through thick seams, etc.
- **The width of the shaft of an embroidery needle** limits the the finest possible detail (the smallest possible stitch). Standard size (75/11) needles are .75 mm across, so stitches must be at least a little wider than the hole that the needle punches in the fabric (minimum distance 1mm)
- **Needles are subject to wear!** Over time, burred surfaces and other wear can cause problems. Be prepared to change needles frequently especially with heavy use.

